



2019年版

管件与阀门选型样本

Piping & Valve Catalogue

安徽天康(集团)股份有限公司
ANHUI TIANKANG (GROUP) SHARES CO., LTD.

GROUP INTRODUCTION

集团简介

长江宛如一条巨龙奔腾不息，在长江之滨的天长市有这样一颗璀璨的明珠--安徽天康（集团）股份有限公司，在经历了岁月的历练与洗礼后愈发闪耀夺目。

安徽天（集团）股份有限公司创建于1974年，总部位于“长三角”经济圈核心区域--天长市，是中国民营企业制造业500强企业、中国电子信息百强企业、国家级守合同重信用企业、国家高新技术企业、安徽省依法纳税先进企业、银行资信AAA级企业、中国仪表行业十强企业、中国电线电缆10强企业、安徽省重点骨干企业。

天康集团历经四十年的蓬勃发展，已形成集仪器仪表、光电缆、医疗卫生、锂电池等跨行业、多元化的集团公司，下属子公司达二十余家。旗下产品凭借良好的质量和服务，被广泛应用于石油、电力、化工、通讯、卫生、新能源汽车及储能等行业和领域。其自主研发、生产的纳米钛酸锂动力/储能电池产品属国家重点新产品，经业内专家评定，达到国内领先、国际先进水平。

作为皖东经济最具活力与贡献的骨干企业之一，天康集团以“追求卓越，缔造满意”为目标，依托一流的产品、一流的管理、一流的服务，不仅在国内市场中赢得了广泛赞誉，在国际市场中，天康产品远销欧洲、非洲、亚洲等46个国家和地区、出口额连年攀升。

天康集团在发展中逐步形成了独特的品牌文化及着眼全球的经营布局，全力塑造“高科技、高品质、国际化”的品牌形象。始终秉承“有跨越才有卓越”的天康精神，在创建和谐企业的基础上，引进国际先进的构架与模式，组织企业的生产经营管理体系，在积极参与国际化竞争的基础上，不断把握市场发展脉搏，寻求经济战略联盟，与全球伙伴共同发展与进步。如今天康人将全心的投入化为无私的奉献，与世界共同发展，与人类一起进步。



Yangtze River like a unceasing huge dragon,there is a bright Pear-Anhui Tiankang(Group)Shares Co.,Ltd in Tianchang city on bank of Yangtze River,it is more and more dazzling through years of experience and baptism.

Anhui Tiankang(Group)Shares Co.,Ltd was established in 1974,head quarter lies in tianchang city-the economic core district of Yangtze River delta area.Tiankang won several titles,such as" 500 top enterprises of national private manufacturing enterprises" ," Top Hundred electrical information enterprise" ," National Trustable Enterprise" ," National Hi-tech Enterprise" ," Provincial Top Tax Payer" ," Class-AAA Credit Enterprise" ," National Top 10 Enterprises in instrument industry" ," National Top 10 enterprises in cable&wire industry" as well as" Key Enterprise in Anhui Province" .

After 40 years' rapid growth,Anhui Tiankang (Group)Shares CO.,Ltd becomes a cross-industry, diversified group company including instrumentation,cable,optical fiber cable,lithium battery,medical treatment and public health industries,etc,with over twenty branches and companies,Depending on good quality and service,our products are widely used in petrochemical industry,power battery/Energy storage battery is national new key product.According to industry expert assessment,it reaches domestic leading,international advanced level.

As one of the most dynamic economic and largest contribution key enterprises in eastern ,Anhui province,Tian kang group pursue for outstanding and satisfactory achievement with image of the first class products,top management and Superior of Europe,Africa,Asia and etc.Export continue to climb in successive years.

With development,Anhui Tiankang(Group)Shares CO.,Ltd gradually form a unique brand culture and the global business layout,we are making great effect to create brand image of High-tech,high quality ,internationalization,We are consistently persevering in spirit of Tiankang" innovation makes excellent" . On the basis of establishing harmonious enterprise,we import international advanced management system to organize group enterprises,actively participate in international competition.constantly grasp the pulse of market development and actively seek economic strategic alliance,common development and progress, Our Tiankang people unselfishly dedicate ourselves to common development with the world and together progress with human.



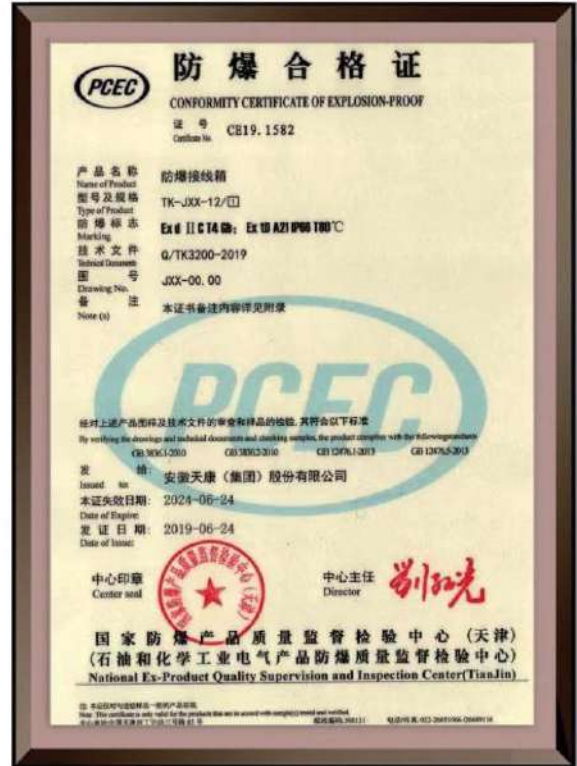
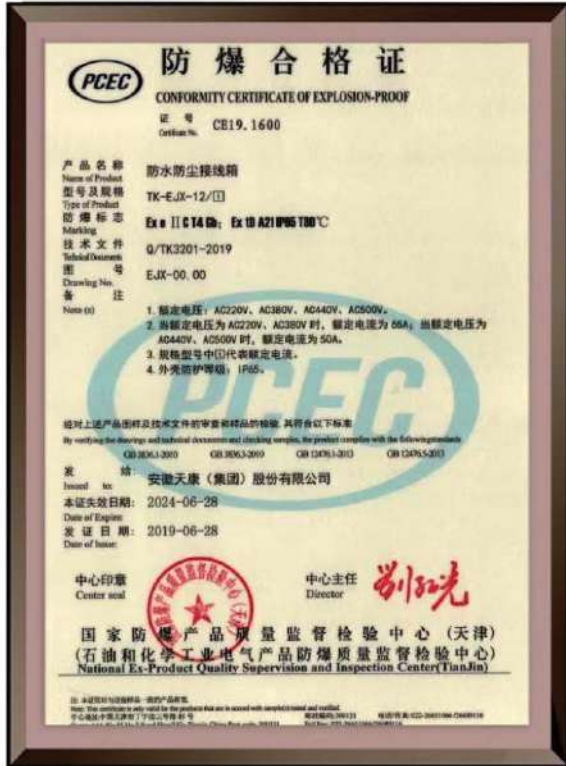



随着国家对安全生产越来越重视，近而对制造业的产品质量也在不断地提高要求，为了满足日益提高的市场需要，公司从材料、工艺、设备、检测等各方面深入研究，生产出一批高品质、高精度、高水准的管阀件产品，经过第三方检测各项数据均能达到国外进口产品水平，很好地迎合了国家提出的进口产品国产化方针。

整体阀帽式针阀 Integral bonnet needle valves



用途：

仪器仪表隔离 一般服务 测试台
测试阀 试验设备

说明：

最大工作压力：6000PSIG(413BARG)@100° F(38°C)
使用温度：-65° F(-54°C)to 450° F(232°C)

特点：

直通式，角式
不锈钢，镍基合金，合金400（蒙乃尔）
PTFE 2片式填料
金属对金属密封或者PCTFE
软密封阀座（气密性）

Applications

instrument isolation,
General service,
test stands
test valves, pilot plants

Specifications

Maximum Operating Pressure:
6000PSIG(413BARG)@100° F(38°C)
Operating Temperature Range:
-65° F(-54°C)to 450° F(232°C)

Features

In-line, angle pattern
Stainless steel, Nickel-based alloys,
Alloy 400(Monel)
PTFE 2-piece chevron stem packing
Metal to metal seat or PCTFE
soft seat(bubble tight)

高压针阀 High - pressure needle valves

用途：

耐腐蚀性
高温高压适用
放射性和热冷凝水适用

说明：

最大工作压力：
10000PSIG(689BARG)@100° F(38°C)
使用温度：
-65° F(-54°C)to 1200° F(648°C)

特点：

直通式，角式
不锈钢，碳钢，合金400（蒙乃尔）
镍基合金
高温石墨填料
金属对金属密封
后密封式阀杆保证安全性

Applications

Handling corrosives,
High temperature and pressure
radioactive and hot condensate

Specifications

Maximum Operating Pressure:
10000PSIG(689BARG)@100° F(38°C)
Operating Temperature Range:
-65° F(-54°C)to 1200° F(648°C)

Features

In-line, angle pattern
Stainless steel, Carbon Steel, Alloy 400(Monel),
Nickel-based alloys
High temperature grafoil packing
Metal to metal seat
Back Seat stem for safety



整体阀帽式针阀 Integral Bonnet Needle Valves



用途：

取样系统 高温高压

说明：

最大工作压力：
10000PSIG(689BARG)@100° F(38°C)
使用温度：
-65° F(-54°C) to 1200° F(648°C)

特点：

直通式，角式
不锈钢，碳钢，合金400（蒙乃尔），
镍基合金
高温石墨填料
金属对金属密封

Applications

Sampling System
High temperature and pressure

Specifications

Maximum Operating Pressure:
10000PSIG(689BARG)@100° F(38°C)
Operating Temperature Range:
-65° F(-54°C) to 1200° F(648°C)

Features

In-line, angle pattern
Stainless steel, Carbon steel, Alloy 400(Monel)
Nickel-based alloys
High temperature grafoil packing
Metal to metal seat

针阀 Bar stock needle valves

用途：

仪器仪表隔离 高水蒸气或液体

说明：

最大工作压力：6000PSIG(413BARG)
使用温度：-65° F(-54°C)to 450° F(232°C)

特点：

直通式不锈钢，合金400（蒙乃尔），
双相不锈钢镍基合金PTFE密封使用寿命长
金属对金属密封或PCTFE软密封（气密性）

Applications

Instrument Isolation, Gas, Vapor or Liquid

Specifications

Maximum Operating Pressure:
6000PSIG(413BARG)
Operating Temperature Range:
-65° F(-54°C)to 450° F(232°C)

Features

In-line pattern Stainless Steel, Alloy 400(Monel),
Duplex, Nickel-based alloys PTFE packing provides
leak tight seal and long life cyclical Metal-to-Metal
Seat or PCTFE Soft Seat(Bubble tight)



高端阀门集锦

3片式球阀 3-piece Ball Valves

用途：

仪器仪表气体管道装置
化学物品处理过程
油气的生产设备中

说明：

最大工作压力：3000PSIG(207BARG)@100° F(38°C)
使用温度：-20° F(-28°C)-450° F(232°C)

特点：

直通型
不锈钢, CF8M
可长久旋转
易向外旋出设计防静电锁紧装置
根据API607,
BS6755 第2部分的防火安全规定设计。

Applications

Instrument Air lines
Chemical Processing
Oil & Gas Production

Specifications

Maximum Operating Pressure :
3000PSIG(207 BARG)@100° F(38°C)
Operating Temperature Range :
-20° F(-28°C) to 450° F(232°C)

Features

In-line pattern
Stainless Steel, CF8M
Long life cycle
Easy swing out construction
Anti-static device Locking device
Fire safety designed to API607, BS6755 Part2



棒料球阀 Bar Stock Ball Valves



用途：

仪器仪表气体管道装置
化学物品处理过程
油气的生产设备中

说明：

最大工作压力：6000PSIG(413BARG)
使用温度：-20° F(-28°C)-450° F(232°C)

特点：

直通型
不锈钢,
可长久旋转

Applications

Instrument Air lines
Chemical Processing
Oil & Gas Production

Specifications

Maximum Operating Pressure :
6000PSIG(413BARG)
Operating Temperature Range :
-20° F(-28°C) to 450° F(232°C)

Features

In-line pattern
Stainless Steel, CF8M
Long life cycle

一体式球阀 One - piece ball valves

用途：

仪器仪表气体管路取样钢瓶系统精炼厂试验设备

说明：

最大工作压力：
3000PSIG(207BARG)@70° F(21°C)
使用温度：
50° F(10°C)to 150° F(65°C)

特点：

可多点传递3路, 4路, 5路不锈钢,
镍基合金, 合金400 (蒙乃尔) PTFE密封
两片式密封将球体
完全包裹住容易清洗最小的死角

Applications

Instrument Air lines, Sampling System
Refinery Pilot Plants

Specifications

Maximum Operating Pressure:
3000PSIG(207BARG)@70° F(21°C)
Operating Temperature Range:
50° F(10°C)to 150° F(65°C)

Features

Available in Multi Ports with3-way, 4-way, 5-way...
Stainless Steel, Nickel-based alloys,
Alloy 400 (Monel)PTFE SEATS
Two-piece seat fully encapsulates the ball
Minimum dead space is easily cleaned



耳轴球阀 Trunnion ball valves



用途：

仪器仪表气体管路取样系统

说明：

最大工作压力：10000PSIG(689BARG)@70° F(21°C)
使用温度：0° F(-17°C)to 250° F(121°C)

特点：

直通式不锈钢, 镍基合金, 合金400 (蒙乃尔)
提升设计氟橡胶O形圈密封/阀座可供大流量

Applications

Instrument Air lines, CNG dispensing Sampling System

Specifications

Maximum Operating Pressure:
10000PSIG(689BARG)@70° F(21°C)
Operating Temperature Range:
0° F(-17°C)to 250° F(121°C)

Features

2-way, 3-way, designs Stainless Steel,
Nickel-based alloys,
Alloy 400 (Monel) Trunnion bearings eliminate galling
Spring loaded ball seats PCTFE seats

止回阀 Check valves



用途：
防止回流低压直通式安全阀起泄放作用净化系统

说明：
最大工作压力：6000PSIG(413BARG)@70° F(21°C)
使用温度：-10° F(-23°C)to 400° F(204°C)
开启压力：1/3PSIG (0.02BARG) -25PSIG (1.7BARG)

特点：
直通式不锈钢，镍基合金，合金400 (蒙乃尔)
提动设计支持大流量
频跳和波动降低到最低氟橡胶O型圈密封

Applications

Prevent reversed flow low pressure In-line relief valve
Vent valve to purge system

Specifications

Maximum Operating Pressure: 6000PSIG(413BARG)@70° F(21°C)
Operating Temperature Range: -10° F(-23°C)to 400° F(204°C)
Opening Pressure: 1/3PSIG (0.02 BARG) to 25 PSIG (1.7BARG)

Features

In-line pattern Stainless Steel, Nickel-based alloys,
Alloy 400(Monel) Poppet design Provide large flows
Minimum of chatter and fluctuation Viton O-ring seats/Seals

排放阀和清洗阀 Bleed and Purge Valves

用途：
用于排放或者清洗液体和气体

说明：
最大工作压力：6000PSIG(413BARG)@100
使用温度：-65° F (-54°C)-850° F(454°C)

特点：
直通式
不锈钢，镍基合金，和碳钢材质
结构紧凑

Applications

Venting or purging of liquids
and gases

Specifications

Maximum Operating pressure :
6000 PSIG(413 BARG)@100° F (38°C)
Operating Temperature Range:
-65° F (-54°C) to 850° F(454°C)

Features

In-line pattern
Stainless Steel, Nickel-based alloys,
Carbon Steel
Compact design



过滤器系列 Filters series

用途：
分离杂质保护灵敏仪器
用于取样管路系统

说明：
最大工作压力：6000PSIG(413BARG)@70° F(21°C)
使用温度：-10° F(-29°C)to 400° F(204°C)
过滤原件大小：1-150Micron

特点：
T型设计不锈钢，镍基合金
过滤原件容易更换
支持分流
提供净化和取样功能

Applications

Trap foreign particles. Protect sensitive
equipment, Sampling system

Specifications

Maximum Operating Pressure:
6000PSIG(413BARG)@70° F(21°C)
Operating Temperature Range:
-10° F(-29°C)to 400° F(204°C)
Fukterubg range: 1 to 1 50 Micron

Features

Tee pattern
Stainless Steel, Nickel-based alloys
Easy replacement of filter elements
Available by-pass
Provided purging and sampling

比例卸荷阀 Proportional Relief Valves

用途：
液体与气体环境

说明：
最大工作压力：6000PSIG(413BARG)@70° F(21°C)
使用温度：-10° F(-23°C)to 400° F(204°C)

特点：
不锈钢，镍基合金，合金400 (蒙乃尔)
设计支持大流量
频跳和波动降低到最低氟橡胶O型圈密封

Applications

Liquid or gas service

Specifications

Maximum Operating Pressure: 6000PSIG(413BARG)@70° F(21°C)
Operating Temperature Range: -10° F(-23°C)to 400° F(204°C)

Features

Stainless Steel, Nickel-based alloys, Alloy 400(Monel)
Poppet design Provide large flows
Minimum of chatter and fluctuation Viton O-ring seats/Seals



高端阀门集锦

表阀和仪表阀组 Gauge valves and instrument manifolds series



用途：
压力表&差压表仪器仪表

说明：
最大工作压力：
10000PSIG(689BARG)@100° F(38°C)
使用温度PTFE填料：
-65° F(-54°C)to 450° F(232°C)
石墨填料：
-65° F(-54°C)to 1200° F(648°C)

特点：
2路, 3路, 5路组合设计不锈钢,
合金400 (蒙乃尔), 碳钢, 镍基合金可直接
或间接安装隔离, 校准或排渣可选PEEK或PTFE密封

Applications

Pressure & Differential Pressure Instrumentation

Specifications

Maximum Operating Pressure:
10000PSIG(689BARG)@100° F(38°C)
Operating Temperature Range:
PTFE Packing:-65° F(-54°C)to 450° F(232°C)
Grafoil Packing:-65° F(-54°C)to 1200° F(648°C)

Features

2-Valves, 3-Valves, 5-Valves, Manifolds designs
Stainless Steel, Alloy 400(Monel),
Carbon Steel, Nickel-based alloys
Available direct or remote
mounting Isolation,
calibration and vent
available PEEK or
PTFE seats

双隔离排泄阀 Double block & bleed valves

用途：
隔离取样化学药剂注入

说明：
最大工作压力：
Class2500(6000PSIG)@100° F(38°C)
使用温度：
PEEK阀座：-65° F(-54°C)-400° F(204°C)
PTFE阀座：-22° F(-30°C)-356° F(180°C)

特点：
两个球阀一个针阀不锈钢, 双相钢, 碳钢
镍基合金节约空间和重量, 方便安装,
节约成本增加安全性方便安装和维修
PEEK或者PTFE密封根据API607/6FA防火设计

Applications

Primary isolation, Sampling,
Chemical injection

Specifications

Maximum Operating Pressure:
Class2500(6000PSIG)@100° F(38°C)
Operating Temperature Range:
PEEK Seat : -65° F(-54°C) to 400° F(204°C)
PTFE Seat : -22° F(-30°C) to 356° F(180°C)

Features

Two ball One needle (OS&Y)
Stainless Steel, Duplex, Carbon Steel,
Nickel-based alloys
Savings on space, weight,
installation and cost
Increased safety
Easy installation and maintenance
PEEK or PTFE seats
Fire safety designed to API 607/6FA



波纹管密封阀 Bellows - sealed valves

说明：
工作压力最高达：2500 PSIG (172 BARG)
使用温度：-320° F to -700° F (-196°C - 371°C)
多种连接方式可选择壳体316 材质
E-JOE 的波纹管密封的产品出厂时密封座,
壳体全都按最大泄漏率4 x 10⁻⁹ std cm³/s
标准在100%氦气中检验。

Specifications

Working pressure up to 2500 PSIG (172 BARG)
Working temperatures from -320° F to 700° F (-196°C to 371°C)
Wide variety options of end connections
316 SS body materials Every E-JOE bellows-sealed valve
is factory tested with helium to a maximum leak rate of 4 x 10⁻⁹
std cm³/s at the seat, envelope and all seals

超高压接头 Ultrahigh pressure fittings

用途：
可用于水流切割, 清洁和生产油气产品的设备中。

说明：
最大工作压力：
30000PSIG(2068BARG)@100° F(38°C)
使用温度：
-325° F(-198°C)-1200° F(648°C)

特点：
锥形螺纹的螺纹连接设计
不锈钢, 镍基合金
可重复装配和拆卸
增强了承受压力能力
可用于酸性气体

Applications

Water jet cutting and cleaning
Oil and Gas production

Specifications

Maximum Operating pressure :
30000PSIG(2068BARG)@100° F(38°C)
Operating Temperature Range:
-325° F(-198°C) to 1200° F(648°C)

Features

Coned&threaded connection design
Stainless Steel, Nickel-based alloys
Repeated assembly and disassembly
Increased pressure handling capability
Sour gas service available



Y型整体锻造截止阀 One Body Forged steel globe valve



用途:
蒸汽环境

说明:
最大工作压力: 4500磅级
使用温度:
-65° F (54°C) to 1200° F (648°C)

特点:
一体式锻造无阀帽截止阀, 没有可导致泄漏的阀帽连接。
维护时, 不需要切割阀帽, 没有需拆卸的螺纹阀帽。
与直通型截止阀相比, 65o型截止阀压降更小。

Applications
Steam service

Specifications
Maximum Operating Pressure: Class 4500
Operating Temperature Range:
-65° F (54°C) to 1200° F (648°C)

Features
One-piece, forged, bonnetless globe valves eliminate the potential for body-to-bonnet joint leakage, and not require cut or disassemble the bonnet for servicing.
65 inclined body reduces pressure drop compared with T-type.
The non-rotating stem hardened and polished to reduce operating torque.

Y型分体锻造截止阀 Forged steel globe valve

用途:
蒸汽环境

说明:
最大工作压力: 4500磅级
使用温度:
-65° F (54°C) to 1200° F (648°C)

特点:
分体式锻造螺纹阀帽截止阀, 没有可导致泄漏的阀帽连接。
维护时, 不需要切割阀帽。
与直通型截止阀相比, 65o型截止阀压降更小。

Applications
Steam service

Specifications
Maximum Operating Pressure: Class 4500
Operating Temperature Range:
-65° F (54°C) to 1200° F (648°C)

Features
Two-piece, forged, bonnetless globe valves eliminate the potential for body-to-bonnet joint leakage, and not require cut the bonnet for servicing.
65 inclined body reduces pressure drop compared with T-type.
The non-rotating stem hardened and polished to reduce operating torque.



超高压针阀 Ultrahigh pressure needle valves



用途:
其重要特征使其广泛应用于各种环境中

说明:
最大工作压力: 30000PSIG(2068BARG)
使用温度: -20° F 1200° F(-28°C-648°C)

特点:
连接尺寸范围: 1/4"-9/16"
不可旋转阀杆和填料的结构设计。
易于组装和更换填料
硬化了的阀座可达到理想的关闭, 延长了在粗糙介质中的阀杆和阀座的使且寿命, 更好的防腐性能, 并且提高了周期性不断重复的开启和关闭的持久力。
标准的填料为PTFE, 也可使用RPTFE玻璃和石墨作为填料用石墨作为填料的温度可达到1200° F(648°C)
填料压盖和阀杆材料的选择可以减少手柄的扭矩, 并且延长了螺纹的寿命
阀体材质为316SS, 阀杆材质为17-4PHSS
有V型阀杆尖和可调节阀杆尖可供选择
可实现填料压盖的锁紧装置
五种流通模式可供选择

Applications
Widely used in various environments

Specifications
MAX. Working pressure :
up to 30000PSIG(2068BARG)
temperature ratings :
-20° F -1200° F(-28°C-648°C)
temperature service

Features
Tubing sizes from 1/4"to 9/16".
Non-rotating stem and bar stock body design
Easy to assemble and replace packing
Metal-to-metal seating achieves ideal shutoff, longer stem/seat service lifetime for abrasive flow, excellent corrosion resistance and greater durability for repeated on/off cycles PTFE is the standard packing material, RPTFE glass and graphite also available Extend stuffing box valve with of Graphite can be operate to 1200° F(648°C)The material of packing gland and stem sleeve have been selected to achieve reduced handle torque and extended thread cycle life
The material of valve body is 316SS, the material of valve-stem is 17-4PHSS
Options for vee or regulating stem tips
The locking device of packing gland is reliable
Five flow patterns are available

高端阀门集锦

卡套接头 Tube fittings

用途：

仪器仪表高温高压，低温

说明：

最大工作压力：

9000PSIG(621BARG)@100° F(38°C)

使用温度：

-321° F(-196°C)to 1200° F(648°C)

特点：

双卡套设计

不锈钢，镍基合金，合金400(蒙乃尔)，双相钢

可完全互换

可检测性，抗震能力

可重复安装

Applications

Instrumentation, High pressure and temperature, Cryogenic service

Specifications

Maximum Operating Pressure:

9000PSIG(621BARG)@100° F(38°C)

Operating Temperature Range:

-321° F(-196°C)to 1200° F(648°C)

Features

Compression type double ferrule design
Stainless steel, Nickel-based alloys, Alloy 400(Monel), Duplex
Complete interchangeability
Gaugeability Vibration resistance
Excellent make and re-make life



螺纹接头 Pipe fittings

用途： 液压

说明：

最大工作压力：

Class 2000(S80), 3000(S160),6000(XXS)

对于螺纹接头：

Class 3000(S80), 6000(S160),9000(XXS)

对于承插焊接头：

使用温度：-325° F(-198°C)- 1200° F(648°C)

特点：

管螺纹，承插焊连接

不同螺纹连接，NPT BSPT BSPP SAE

直螺纹ISO公制螺纹

不锈钢，碳钢，镍基合金

ASME B16.11/BS3799/JISB236/MSS-SP95标准

永久可靠的连接



Applications

Hydraulic

Specifications

Maximum Operating Pressure:

Class 2000(S80), 3000(S160),6000(XXS)

For thread fittings:

Class 3000(S80), 6000(S160),9000(XXS)

For Socket weld fittings:

Operating Temperature Range:

-325° F(-198°C)to 1200° F(648°C)

Features

Pipe thread, Socket&weld end Variety of thread end-NPT, BSPT, BSPP SAE Straight, ISO&Metric Stainless Steel, Carbon steel Nickel-based alloys, According to ASME B16.11 /BS3799/JISB2316/MSS-SP95 Permanent and reliable connections

焊接接头 Weld fittings

用途：

螺纹一般用途仪器仪表焊接腐蚀性流体，热循环震动

说明：

最大工作压力：10000PSIG(689BARG)@100° F(38°C)

使用温度：-325° F(-198°C)- 1200° F(648°C)

特点：

ASME B1.20.1 (NPT)，承插焊不锈钢，镍基合金，

碳钢ASME B31.1&31.3标准

Applications

Thread General service, Instrumentation
Weld Corrosive fluids, Temperature cycling, Vibration

Specifications

Maximum Operating Pressure:

10000PSIG(689BARG)@100° F(38°C)

Operating Temperature Range:

-325° F(-198°C)to 1200° F(648°C)

Features

ASME B1.20.1 (NPT)，Tube socket
weld Stainless steel,
Nickel-based alloys, Carbon steel According
to ASME B31.1&31.3



快速接头 Quick-Connects

用途： 液压

说明：

最大工作压力：6000PSIG(413BARG)@70° F(21°C)

使用温度：-10° F(-23°C)to 400° F(204°C)

特点：

不同螺纹连接，NPT BSPT BSPP SAE

直螺纹ISO公制螺纹

不锈钢，镍基合金

ASME B16.11/BS3799/JISB236/MSS-SP95标准

永久可靠的连接



Applications

Hydraulic

Specifications

Maximum Operating Pressure: 6000PSIG(413BARG)@70° F(21°C)

Operating Temperature Range: -10° F(-23°C)to 400° F(204°C)

Features

Pipe thread, Variety of thread end-NPT, BSPT, BSPP SAE Straight, ISO&Metric Stainless Steel, Nickel-based alloys, According to ASME B16.11 /BS3799/JISB2316/MSS-SP95 Permanent and reliable connections



直通终端接头



(锥度螺纹)直通终端接头



卡套式终端接头



(锥度螺纹)卡套式终端接头



焊接式弯通接头



焊接式三通接头



对焊式三通接头



仪表底座



冷凝圈



冷凝弯



虹吸管



隔离容器



分离容器



冷凝容器



外螺纹截止阀(20#钢)



外螺纹截止阀(不锈钢)



高温型外螺纹截止阀



内螺纹截止阀



角式法兰截止阀



法兰截止阀



角式外螺纹截止阀



压力表截止阀



节流截止阀



高温高压截止阀(不锈钢)



高温高压截止阀(12Cr1MoV)



压力计截止阀



排泄截止阀



阻尼阀

常规产品摘要



多口计量阀



卡套式外螺纹截止阀



外螺纹三通截止阀

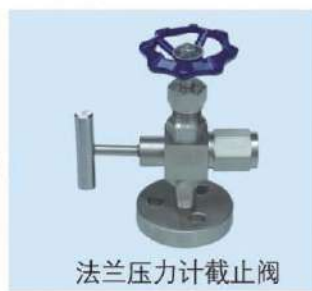

法兰压力计截止阀



取压截止阀



卡套式气动管路截止阀



排气阀



疏水器



压力表球阀



外螺纹球阀



气源球阀



卡套式球阀



内螺纹球阀



取压球阀



二阀组



一体化二阀组



二阀组



二阀组 (20#钢)



一体化三阀组



(1151) T型三阀组



(1151) I型三阀组



法兰二阀组



天然气管道专用阀



NGz PVC包塑金属防尘挠性管



NGe 橡胶护套增安防爆挠性管



NGe 尼龙护套增安防爆挠性管



NGd 隔爆挠性管



不锈钢隔爆挠性管



外螺纹式金属软管接头



顶丝式金属软管接头

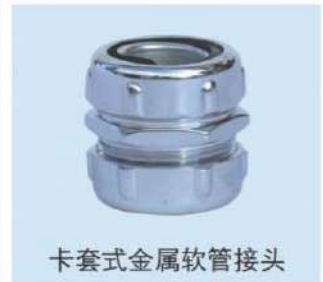

卡套式金属软管接头



90度弯通穿线盒

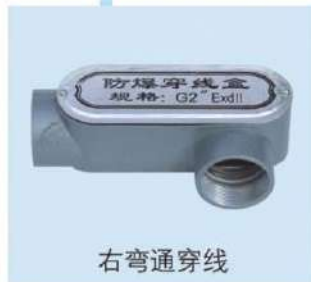

右弯通穿线盒



直通穿线盒



后弯通穿线盒



三通穿线盒

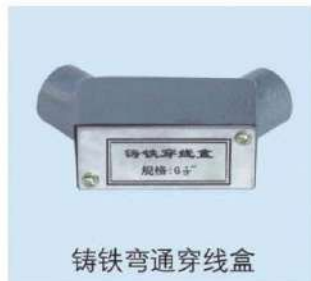

铸铁弯通穿线盒



防爆接线盒



Y型防爆隔离密封接头



横向型防爆隔离密封接头



排水型防爆隔离密封接头

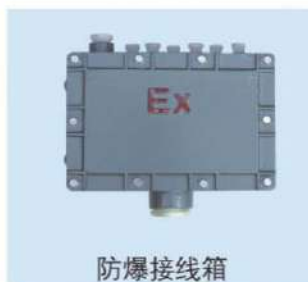

防爆接线箱



铠装电缆密封接头 A



铠装电缆密封接头 B



铠装电缆密封接头 C



电缆密封接头 D

目 录 CONTENTS

管 件 与 仪 表 附 件

TKG1 S系列钢制双卡套式管接头	1
TKG1 S Pipe connector of cutting sleeve type	
TKG1 系列钢制单卡套式管接头	9
TKG1 Steel tube Fitting of single ferrule	
TKG2 铜制气动管路接头 (铜管、尼龙管用)	10
TKG2 Copper bayonet joint for use in pneumatic pipe	
TKG3 铜制气动管路接头 (塑料管用)	15
TKG3 Copper pneumatic piping connector	
TKG4 系列扩口式管接头	17
TKG4 Flared fitting	
TKG5 焊接式管接头	18
TKG5 Welding pipe connector	
TKG6-16 系列自控管路附件	26
TKG6-16 Gauge pipe auxiliary	
TKF 系列仪表辅助容器	37
TKF Gauge auxiliary container	
TKKFQ 系列气源分配器	39
TKKFQ Gas distributor	
防堵风压取样装置	40
Anti-wind pressure sampling device	
TKYX Ⅳ系列仪表保温保护箱	41
TKYX Ⅳ Gauge Heat-proof and protect box	

仪 表 阀 门 与 阀 组

TK6 系列气动管路截止阀	47
TK6 Pneumatic tube stop valve	
TK7 系列气动管路截止阀 (塑料管用)	51
TK7 Pneumatic tube stop valve	
TKJ 系列测量管路截止阀	53
TKJ Measurement tube stop valve	
TKQ 系列测量管路球阀	62
TKQ Ball valve for measure pipeling	
TK 仪表系列阀组	70
TK Gauge series valves	
TKZ 系列闸阀	76
TKZ Gate valves	

防 爆 管 件

TKNG Ⅱ系列防爆挠性连接管	78
TKNG Ⅱ Explosion-protected Flexible Connecting Pipes	

TKBHC 系列防爆穿线盒	80
TKBHC Type Explosion-proof Cable-passing Box	
TKBXJ51 系列防爆接线箱	85
TKBXJ51 Type Explosion-proof Junction Box	
TKZxd、Hxd、Psd 系列防爆隔离密封管接头	87
TKZxd、Hxd、Psd series Flame-proof Sealing Connector	
TKYFD 型有机防火堵料	88
TKYFD Fire - proof organic material	
TKBHJ 系列防爆活接头	89
TKBHJ Type Explosion-proof Active Connector	
TKDQM 系列电缆夹紧密封接头	90
TKDQM Type Cable-clamped Seal Connector	
TKDTL 系列防爆填料函	94
TKDQM Type Explosion-proof Gasketing Tube	
TKDGJ 系列防爆管接头	95
TKDGJ Type Explosion-proof Pipe Connector	
TKDGJ-b 系列防爆变径接头	96
TKDGJ-b Type Explosion-proof Ruccer Connector	
TKHBC 补偿式防堵吹扫装置	97
TKHBC Compensation Anti - Blocking Purge Device	
TKPSA-T 型气源净化装置	102
TKPSA-T Air Source Purification Unit	
吹扫 (装置) 流量计	108
Purge (device) flowmeter	
安装附件	114
Installing Accessory	

流 量 测 量 装 置

标准孔板	115
Standard Orifice Plate	
标准喷嘴	117
Standard Nozzle	
经典文丘里管 文丘里喷嘴	118
Traditional Wenqiuli Tube, Wenqiuli Nozzle	
机翼测风装置	119
Measuring Wind Device in Airfoil	
双文丘里管	120
Double Wenqiuli Tube	
环形孔板、圆缺孔板、偏心孔板	121
Circular Orifice Plate, Gap-round Orifice Plate, Eccentric Orifice Plate	
双重孔板 1/4 圆喷嘴	122
Double Orifice Plate, 1/4 round Nozzle	
阿牛巴流量计	123
Anuba Effusion Meter	

TKG 1 S系列钢制双卡套式管接头 TKG1 S Pipe Connector of Cutting Sleeve Type

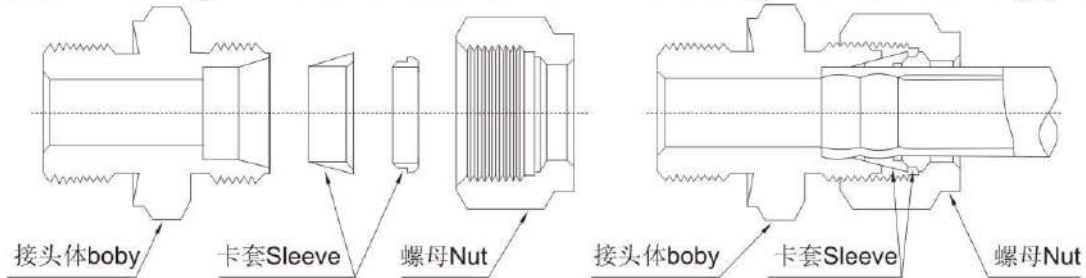

材料: 20#, 1Cr18Ni9Ti, 316、316L
 Material: 20#, 1Cr18Ni9Ti, 316、316L
 公称压力: 16MPa、32MPa
 Rated Pressure: 16MPa、32MPa

- 管径: $\Phi 4 \sim \Phi 22$ 、 $\Phi 1/4'' \sim \Phi 3/4''$
- Pipe Diameter: $\Phi 4 \sim \Phi 22$
- 终端螺纹可为 M、G、ZG、PT、NPT等
- Extreme thread can be M、G、ZG、PT、NPT...

TKG1-1直通终端接头 TKG1-1 Extreme Straight Through Sleeve

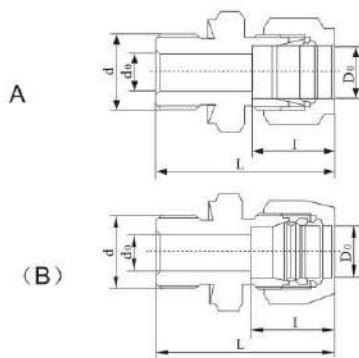

D ₀	d	d ₀	L		I	代 号 CodeNo
			I	II		
4	M10×1	3	43	71	16	TKG1-1A-M10×1-Φ4
6	M10×1	4	43	71	16	TKG1-1A-M10×1-Φ6
8	M10×1	5	47.5	81	20.5	TKG1-1A-M10×1-Φ8
10	M10×1	5	47.5	81	20.5	TKG1-1A-M10×1-Φ10
10	M14×1.5	8	54.5	86	20.5	TKG1-1A-M14×1.5-Φ10
12	M14×1.5	8	55.5	86	23.5	TKG1-1A-M14×1.5-Φ12
12	M18×1.5	10	60.5	96	23.5	TKG1-1A-M18×1.5-Φ12
14	M10×1	5	50.5	81	24.5	TKG1-1A-M10×1-Φ14
14	M14×1.5	8	56.5	86	24.5	TKG1-1A-M14×1.5-Φ14
14	M18×1.5	10	61.5	96	24.5	TKG1-1A-M18×1.5-Φ14
14	M20×1.5	11	61.5	96	24.5	TKG1-1A-M20×1.5-Φ14
16	M18×1.5	10	62.5	98.5	25.5	TKG1-1B-M18×1.5-Φ16
16	M22×1.5	13	62.5	98.5	25.5	TKG1-1B-M22×1.5-Φ16
18	M18×1.5	10	62.5	98.5	25.5	TKG1-1B-M18×1.5-Φ18
18	M22×1.5	15	62.5	98.5	25.5	TKG1-1B-M22×1.5-Φ18

TKG1-2直通终端锥管接头 TKG1-2 Extreme Straight Through Connection for Conical Pipe

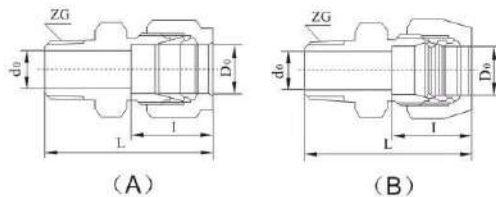

D ₀	ZG	d ₀	L		I	代 号 CodeNo
			I	II		
4	ZG1/8"	3	44	72	16	TKG1-2A-ZG1/8"-Φ4
5	ZG1/8"	3.5	44	75	16	TKG1-2A-ZG1/8"-Φ5
6	ZG1/8"	4	44	77	16	TKG1-2A-ZG1/8"-Φ6
8	ZG1/4"	6	52.5	84.5	20.5	TKG1-2A-ZG1/4"-Φ8
10	ZG1/4"	8	60.5	86.5	20.5	TKG1-2A-ZG1/4"-Φ10
12	ZG3/8"	10	60.5	96.5	23.5	TKG1-2A-ZG3/8"-Φ12
14	ZG1/2"	12	67.5	108	24.5	TKG1-2A-ZG1/2"-Φ14
16	ZG1/2"	14	68.5	110	25.5	TKG1-2B-ZG1/2"-Φ16
18	ZG3/4"	16	68.5	115	25.5	TKG1-2B-ZG3/4"-Φ18

TKG1-3直通中间接头 TKG1-3 Straight-through Sleeve

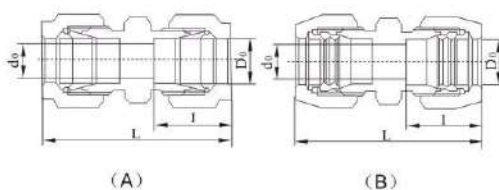

D ₀	d ₀	L	I	代 号 CodeNo
4	3	40	16	TKG1-3A-Φ4
5	3.5	40	16	TKG1-3A-Φ5
6	4	40	16	TKG1-3A-Φ6
8	6	52	20.5	TKG1-3A-Φ8
10	8	52	20.5	TKG1-3A-Φ10
12	10	56	23.5	TKG1-3A-Φ12
14	12	60	24.5	TKG1-3A-Φ14
16	14	63	25.5	TKG1-3B-Φ16
18	16	63	25.5	TKG1-3B-Φ18

TKG 1-4 异径直通中间接头 TKG 1-4 Reducing Straightthrough Union

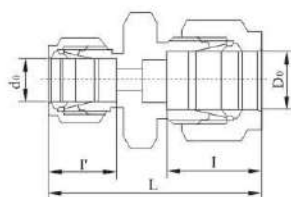

D ₀	d ₀ '	L	l	l'	代 号 Code No
12	6	49.5	23.5	16	TKG1-4-Φ6-Φ12
12	8	54	23.5	16	TKG1-4-Φ8-Φ12
14	6	50.5	24.5	16	TKG1-4-Φ6-Φ14
14	8	55	24.5	24.5	TKG1-4-Φ8-Φ14
14	10	55	24.5	24.5	TKG1-4-Φ10-Φ14

TKG 1-5 直通穿板接头 TKG 1-5 Wall-separating Straight-through Sleeve

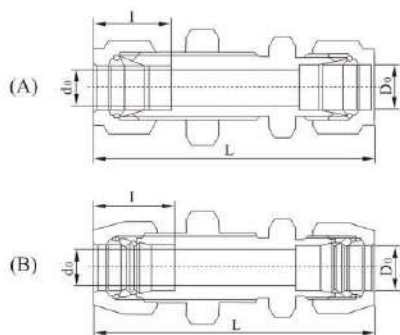

D ₀	d ₀	L	l	代 号 Code No
4	3	58	16	TKG1-5A-Φ4
5	3.5	58	16	TKG1-5A-Φ5
6	4	58	16	TKG1-5A-Φ6
8	6	67	20.5	TKG1-5A-Φ8
10	8	67	20.5	TKG1-5A-Φ10
12	10	73	23.5	TKG1-5A-Φ12
14	12	76	24.5	TKG1-5A-Φ14
16	14	83	25.5	TKG1-5B-Φ16
18	16	83	25.5	TKG1-5B-Φ18

TKG 1-6 压力表直通接头 TKG 1-6 Straight-through Sleeve for Manometer

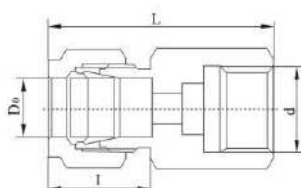

D ₀	d	L	l	代 号 Code No
6	M10×1	31	16	TKG1-6-M10×1-Φ6
6	M14×1.5	38	16	TKG1-6-M14×1.5-Φ6
6	M20×1.5	42	16	TKG1-6-M20×1.5-Φ6
14	M20×1.5	45	24.5	TKG1-6-M20×1.5-Φ14
14	G1/2"	45	24.5	TKG1-6-G1/2"-Φ14

TKG 1-7 压力表直通穿板接头 TKG 1-7 Wall-separating Manometer Straight-through Sleeve

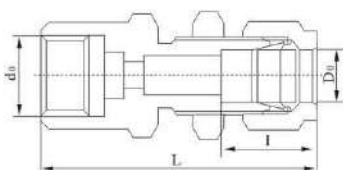

D ₀	d ₀	L	l	代 号 Code No
6	M10×1	55	16	TKG1-7-M10×1-Φ6
6	M14×1.5	62	16	TKG1-7-M14×1.5-Φ6
6	M20×1.5	66	16	TKG1-7-M20×1.5-Φ6
14	M20×1.5	69	24.5	TKG1-7-M20×1.5-Φ14
14	G1/2"	69	24.5	TKG1-7-G1/2"-Φ14

TKG 1-8 组合直通接头 TKG 1-8 Combined Straight Through Sleeve

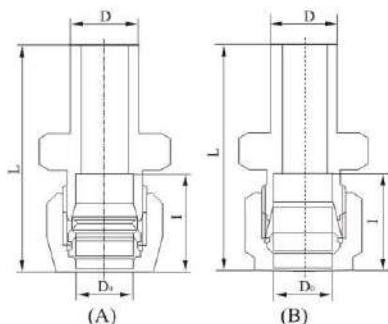

D ₀	D	L	l	代 号 Code No
4	4	41	16	TKG1-8A-Φ4
5	5	41	16	TKG1-8A-Φ5
6	6	43	16	TKG1-8A-Φ6
8	6	47.5	20.5	TKG1-8A-Φ8
10	10	49.5	20.5	TKG1-8A-Φ10
12	12	52.5	23.5	TKG1-8A-Φ12
14	14	54.5	24.5	TKG1-8A-Φ14
16	16	56.5	25.5	TKG1-8B-Φ16
18	18	56.5	26.5	TKG1-8B-Φ18

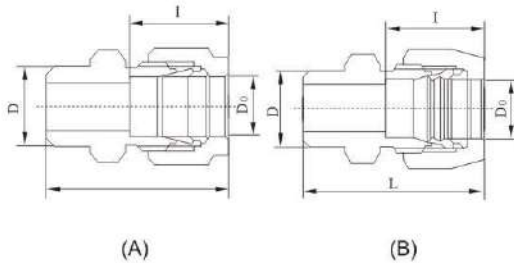
TKG 1-9 焊接直通接头 TKG 1-9 Welding Straight-through Sleeve

D ₀	D	L	I	代号 CodeNo
4	8	31	16	TKG1-9A-Φ4-Φ8
5	8	31	16	TKG1-9A-Φ5-Φ8
6	10	32.7	16	TKG1-9A-Φ6-Φ10
8	11	41.5	20.5	TKG1-9A-Φ8-Φ11
10	13	41.5	20.5	TKG1-9A-Φ10-Φ13
12	15	45.5	23.5	TKG1-9A-Φ12-Φ15
14	17	48.5	24.5	TKG1-9A-Φ14-Φ17
16	19	50.5	25.5	TKG1-9B-Φ16-Φ19
18	21	50.5	25.5	TKG1-9B-Φ18-Φ21

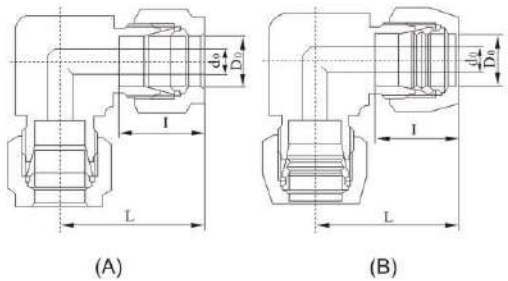
TKG 1-10 弯通中间接头 TKG 1-10 Right-angle Sleeve

D ₀	d ₀	L	I	代号 CodeNo
4	3	28	16	TKG1-10A-Φ4
5	3.5	28	16	TKG1-10A-Φ5
6	4	29	16	TKG1-10A-Φ6
8	6	33.5	20.5	TKG1-10A-Φ8
10	8	36.5	20.5	TKG1-10A-Φ10
12	10	38.5	23.5	TKG1-10A-Φ12
14	12	40.5	24.5	TKG1-10A-Φ14
16	14	42.5	25.5	TKG1-10B-Φ16
18	15	43.5	25.5	TKG1-10B-Φ18

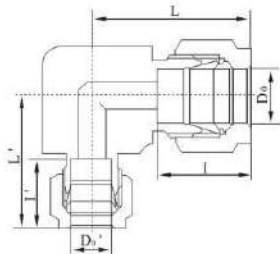
TKG 1-11 异径弯通中间接头 TKG 1-11 Reducing Right-angle Union

D ₀	D ₀ '	L	L'	I	I'	代号 CodeNo
12	6	38.5	31	23.5	16	TKG1-11-Φ6-Φ12
12	8	38.5	35.5	23.5	20.5	TKG1-11-Φ8-Φ12
14	6	40.5	31	24.5	16	TKG1-11-Φ6-Φ14
14	8	40.5	35.5	24.5	20.5	TKG1-11-Φ8-Φ14
14	10	40.5	36.5	24.5	20.5	TKG1-11-Φ10-Φ14

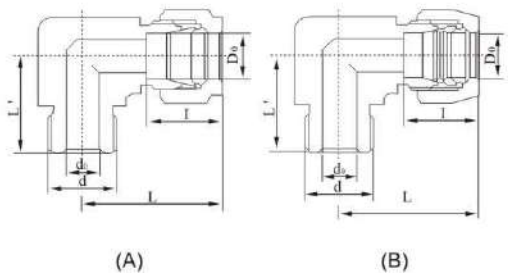
TKG 1-12 弯通终端接头 TKG 1-12 Extreme Right-angle Piping Connector

D ₀	d	d ₀	L	L'	I	代号 CodeNo
4	M10×1	3	30	20	16	TKG1-12A-M10×1-Φ4
6	M10×1	4	32	20	16	TKG1-12A-M10×1-Φ6
8	M10×1	5	35.5	22	20.5	TKG1-12A-M10×1-Φ8
10	M14×1.5	8	39.5	29	20.5	TKG1-12A-14×1.5-Φ10
12	M18×1.5	10	43.5	33	23.5	TKG1-12A-18×1.5-Φ12
14	M18×1.5	10	45.5	34	24.5	TKG1-12A-18×1.5-Φ14
14	M20×1.5	11	45.5	34	24.5	TKG1-12A-20×1.5-Φ14
16	M22×1.5	13	47.5	35	26.5	TKG1-12B-22×1.5-Φ16
18	M22×1.5	15	48.5	37	26.5	TKG1-12B-22×1.5-Φ18

TKG 1-13 弯通终端锥接头 TKG 1-13 Extreme Right-angle Connector for Conical Pipe

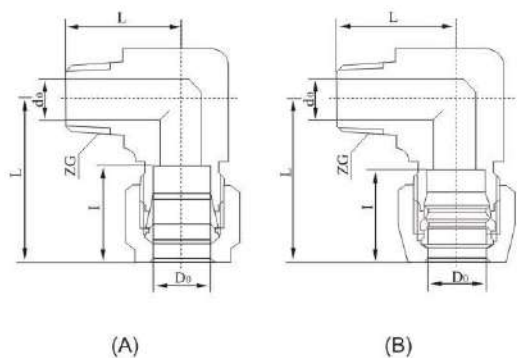

D ₀	ZG	d ₀	L	L'	I	代号 CodeNo
4	ZG1/8"	3	28	22	16	TKG1-13A-ZG1/8"-Φ4
5	ZG1/8"	3.5	28	22	16	TKG1-13A-ZG1/8"-Φ5
6	ZG1/8"	4	29	22	16	TKG1-13A-ZG1/8"-Φ6
8	ZG1/4"	6	33.5	27	20.5	TKG1-13A-ZG1/4"-Φ8
10	ZG1/4"	8	36.5	27	20.5	TKG1-13A-ZG1/4"-Φ10
12	ZG3/8"	10	38.5	28	23.5	TKG1-13A-ZG3/8"-Φ12
14	ZG1/2"	12	40.5	36	24.5	TKG1-13A-ZG1/2"-Φ14
16	ZG1/2"	14	42.5	37	25.5	TKG1-13B-ZG1/2"-Φ16
18	ZG3/4"	16	43.5	37	25.5	TKG1-13B-ZG3/4"-Φ18

TKG 1-14 组合弯通接头 TKG 1-14 Combined Right-angle Piping Connector

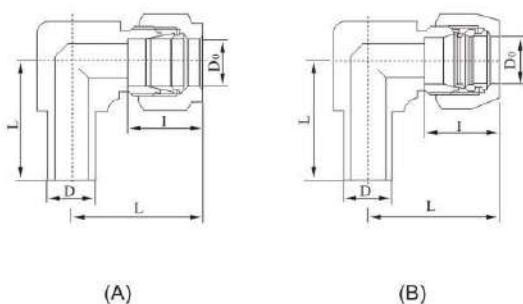

D ₀	D	L	L'	I	代号 CodeNo
4	4	28	27	16	TKG1-14A-Φ4
5	5	28	27	16	TKG1-14A-Φ5
6	6	29	31	16	TKG1-14A-Φ6
8	8	33.5	35	20.5	TKG1-14A-Φ8
10	10	36.5	39	20.5	TKG1-14A-Φ10
12	12	38.5	40	23.5	TKG1-14A-Φ12
14	14	40.5	41	24.5	TKG1-14A-Φ14
16	16	42.5	44	25.5	TKG1-14B-Φ16
18	18	43.5	45	25.5	TKG1-14B-Φ18

TKG 1-15 压力表弯通接头 TKG 1-15 Manometer Right-Angle Sleeve

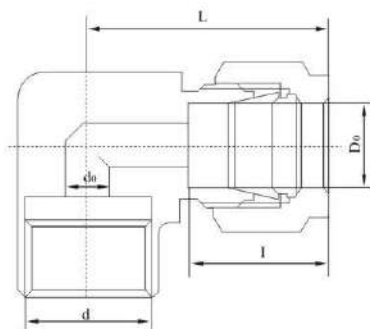

D ₀	d	d ₀	L	I	代号 CodeNo
6	M10×1	4	29.5	16	TKG1-15-M10×1-Φ6
6	M14×1.5	4	31	16	TKG1-15-M14×1.5-Φ6
6	M20×1.5	4	34.5	16	TKG1-15-M20×1.5-Φ6
14	M20×1.5	7	34.5	24.5	TKG1-15-M20×1.5-Φ14
14	G1/2"	7	34.5	24.5	TKG1-15-G1/2"-Φ14

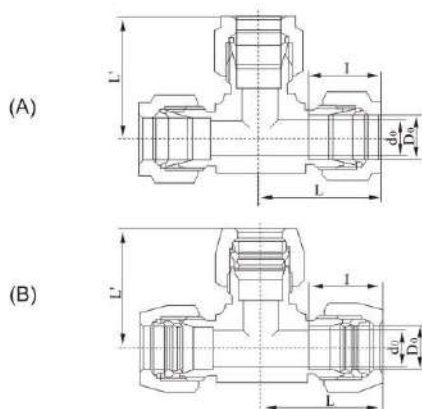
TKG 1-16 三通中接头 TKG 1-16 T-pipe Connector

D ₀	d ₀	L	L'	l	代号Code No
4	3	28	28	16	TKG1-16A-Φ4
5	3.5	28	28	16	TKG1-16A-Φ5
6	4	29	29	16	TKG1-16A-Φ6
8	6	33.5	33.5	20.5	TKG1-16A-Φ8
10	8	36.5	36.5	20.5	TKG1-16A-Φ10
12	10	38.5	38.5	23.5	TKG1-16A-Φ12
14	12	40.5	40.5	24.5	TKG1-16A-Φ14
16	14	42.5	42.5	25.5	TKG1-16B-Φ16
18	15	43.5	43.5	25.5	TKG1-16B-Φ18

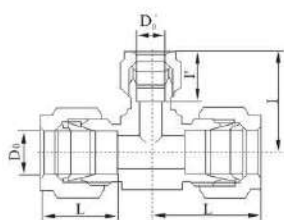
TKG 1-17 异径三通中接头 TKG 1-17 Reducing T-pipe Connector

D ₀	D ₀ '	L	L'	l	l'	代号Code No
12	6	34.5	31	23.5	16	TKG1-17-Φ6-Φ12
12	8	34.5	35.5	23.5	20.5	TKG1-17-Φ8-Φ12
14	6	36.5	31	24.5	16	TKG1-17-Φ6-Φ14
14	8	36.5	35.5	24.5	20.5	TKG1-17-Φ8-Φ14
14	10	36.5	36.5	24.5	20.5	TKG1-17-Φ10-Φ14

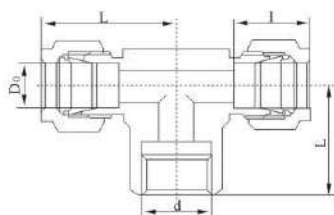
TKG 1-18 压力表三通接头 (一) TKG 1-18 Manpmeter T-pipe Connector(1)

D ₀	d	L	L'	l	代号Code No
6	M10×1	29.5	35	16	TKG1-18-M10×1-Φ6
6	M14×1.5	31	35	16	TKG1-18-M14×1.5-Φ6
6	M20×1.5	34.5	40	16	TKG1-18-M20×1.5-Φ6
14	M20×1.5	34.5	40	24.5	TKG1-18-M20×1.5-Φ14
14	G1/2"	34.5	40	24.5	TKG1-18-G1/2"-Φ14

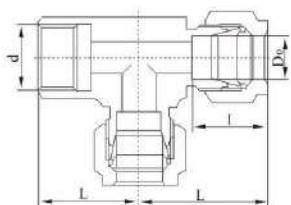
TKG1-19 压力表三通接头 (二) TKG 1-19 Manpmeter T-pipe Connector(2)

D ₀	d	L	L'	l	代号Code No
6	M10×1	29.5	35	16	TKG1-19-M10×1-Φ6
6	M14×1.5	31	35	16	TKG1-19-M14×1.5-Φ6
6	M20×1.5	34.5	40	16	TKG1-19-M20×1.5-Φ6
14	M20×1.5	34.5	40	24.5	TKG1-19-M20×1.5-Φ14
14	G1/2"	34.5	40	24.5	TKG1-19-G1/2"-Φ14

TKG 1-20 组合三通接头 TKG 1-20 Combined T-pipe Connector

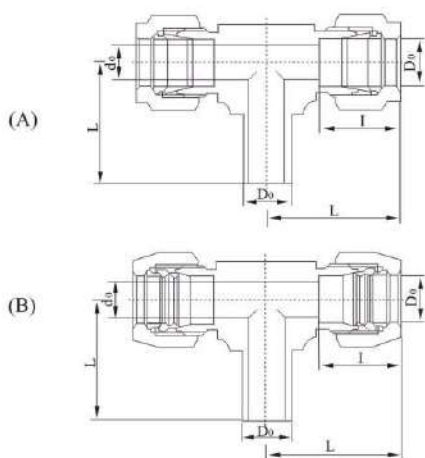

D ₀	d ₀	D ₀ '	L	L'	l	代号 Code No
4	3	4	28	27	16	TKG1-20A-Φ4
5	3.5	5	28	27	16	TKG1-20A-Φ5
6	4	6	29	31	16	TKG1-20A-Φ6
8	6	8	33.5	35	20.5	TKG1-20A-Φ8
10	8	10	36.5	39	20.5	TKG1-20A-Φ10
12	10	12	38.5	40	23.5	TKG1-20A-Φ12
14	12	14	40.5	41	24.5	TKG1-20A-Φ14
16	14	16	42.5	44	25.5	TKG1-20B-Φ16
18	15	18	43.5	45	25.5	TKG1-20B-Φ18

TKG 1-21 三通终端接头 (一) TKG 1-21 Extreme T-pipe Connector(1)

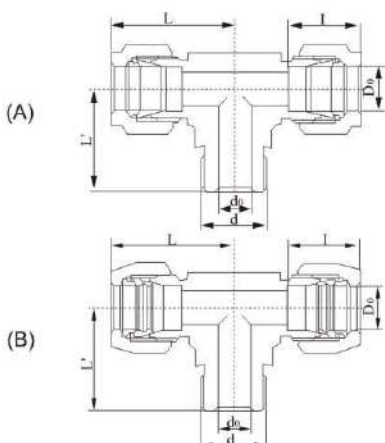

D ₀	d	d ₀	L	L'	l	代号 Code No
4	M10×1	3	30	30	16	TKG1-21A-M10×1-Φ4
6	M10×1	4	32	30	16	TKG1-21A-M10×1-Φ6
8	M10×1	5	35.5	30	20.5	TKG1-21A-M10×1-Φ8
10	M10×1	5	39.5	40	20.5	TKG1-21A-M10×1-Φ10
10	M10×1.5	8	39.5	40	20.5	TKG1-21A-M14×1.5-Φ10
12	M10×1.5	8	43.5	40	23.5	TKG1-21A-M14×1.5-Φ12
12	M10×1.5	10	43.5	44	23.5	TKG1-21A-M18×1.5-Φ12
14	M10×1	5	40	40	24.5	TKG1-21A-M10×1-Φ14
14	M10×1.5	8	40	40	24.5	TKG1-21A-M14×1.5-Φ14
14	M10×1.5	10	45.5	46	24.5	TKG1-21A-M18×1.5-Φ14
14	M10×1.5	11	45.5	46	24.5	TKG1-21A-M20×1.5-Φ14
16	M10×1.5	10	47.5	48	25.5	TKG1-21B-M18×1.5-Φ16
16	M10×1.5	13	47.5	48	25.5	TKG1-21B-M22×1.5-Φ16
18	M10×1.5	10	48.5	49	25.5	TKG1-21B-M18×1.5-Φ18
18	M10×1.5	15	48.5	49	25.5	TKG1-21B-M22×1.5-Φ18

TKG 1-22 三通终端接头 (二) TKG 1-22 Extreme T-pipe Connector(2)

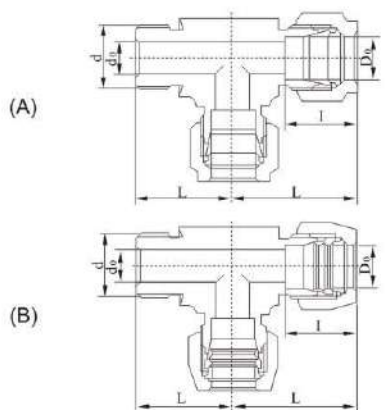

D ₀	d	d ₀	L	L'	l	代号 Code No
4	M10×1	3	28	30	16	TKG1-22A-M10×1-Φ4
6	M10×1	4	29	30	16	TKG1-22A-M10×1-Φ6
8	M10×1	5	33.5	35	20.5	TKG1-22A-M10×1-Φ8
10	M10×1	5	36.5	38	20.5	TKG1-22A-M10×1-Φ10
10	M14×1.5	8	36.5	38	20.5	TKG1-22A-M14×1.5-Φ10
12	M14×1.5	8	38.5	40	23.5	TKG1-22A-M14×1.5-Φ12
12	M18×1.5	10	38.5	40	23.5	TKG1-22A-M18×1.5-Φ12
14	M10×1	5	40.5	42	24.5	TKG1-22A-M10×1-Φ14
14	M14×1.5	8	40.5	44	24.5	TKG1-22A-M14×1.5-Φ14
14	M18×1.5	10	40.5	48	24.5	TKG1-22A-M18×1.5-Φ14
14	M20×1.5	11	40.5	48	24.5	TKG1-22A-M20×1.5-Φ14
16	M18×1.5	10	42.5	50	25.5	TKG1-22B-M18×1.5-Φ16
16	M22×1.5	13	42.5	50	25.5	TKG1-22B-M22×1.5-Φ16
18	M10×1.5	10	43.5	50	25.5	TKG1-22B-M18×1.5-Φ18
18	M22×1.5	15	43.5	50	25.5	TKG1-22B-M22×1.5-Φ18

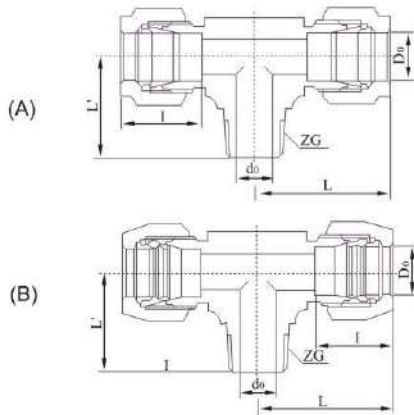
TKG 1-23 三通终端锥管接头 (一) TKG 1-23 Extreme T-pipe Connector for Conical Pipe(1)

D ₀	ZG	d ₀	L	L'	I	代号 Code No
4	ZG1/8"	3	28	22	16	TKG1-23A-ZG1/8"-Φ4
5	ZG1/8"	3.5	28	22	16	TKG1-23A-ZG1/8"-Φ5
6	ZG1/8"	4	29	22	16	TKG1-23A-ZG1/8"-Φ6
8	ZG1/4"	6	33.5	27	20.5	TKG1-23A-ZG1/8"-Φ8
10	ZG1/4"	8	36.5	27	20.5	TKG1-23A-ZG1/8"-Φ10
12	ZG3/8"	10	38.5	28	23.5	TKG1-23A-ZG3/8"-Φ12
14	ZG1/2"	12	40.5	36	24.5	TKG1-23A-ZG1/2"-Φ14
16	ZG1/2"	14	42.5	37	25.5	TKG1-23B-ZG1/2"-Φ16
18	ZG3/4"	16	42.5	37	25.5	TKG1-23B-ZG3/4"-Φ18

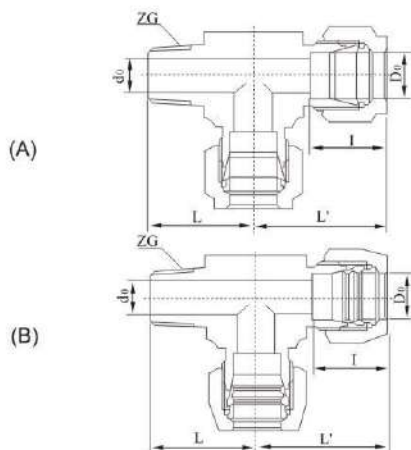
TKG 1-24 三通终端锥管接头 (二) TKG 1-24 Extreme T-pipe Connector for Conical Pipe(2)

D ₀	ZG	d ₀	L	L'	I	代号 Code No
4	ZG1/8"	3	28	22	16	TKG1-24A-ZG1/8"-Φ4
5	ZG1/8"	3.5	28	22	16	TKG1-24A-ZG1/8"-Φ5
6	ZG1/8"	4	29	22	16	TKG1-24A-ZG1/8"-Φ6
8	ZG1/4"	6	33.5	27	20.5	TKG1-24A-ZG1/8"-Φ8
10	ZG1/4"	8	36.5	27	20.5	TKG1-24A-ZG1/8"-Φ10
12	ZG3/8"	10	38.5	28	23.5	TKG1-24A-ZG3/8"-Φ12
14	ZG1/2"	12	40.5	36	24.5	TKG1-24A-ZG1/2"-Φ14
16	ZG1/2"	14	42.5	37	25.5	TKG1-24B-ZG1/2"-Φ16
18	ZG3/4"	16	42.5	37	25.5	TKG1-24B-ZG3/4"-Φ18

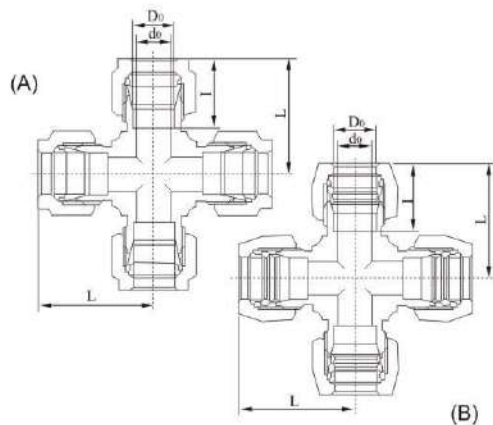
TKG 1-25 四通中间接头 TKG 1-25 Crossbar Connector

D ₀	d ₀	L	L'	I	代号 Code No
4	3	28	28	16	TKG1-25A-Φ4
5	3.5	28	28	16	TKG1-25A-Φ5
6	4	29	29	16	TKG1-25A-Φ6
8	6	33.5	33.5	20.5	TKG1-25A-Φ8
10	8	36.5	36.5	20.5	TKG1-25A-Φ10
12	10	38.5	38.5	23.5	TKG1-25A-Φ12
14	12	40.5	40.5	24.5	TKG1-25A-Φ14
16	14	42.5	42.5	25.5	TKG1-25B-Φ16
18	16	43.5	43.5	25.5	TKG1-25B-Φ18

TKG1-26 堵头 (一) TKG1-26 Ptug(1)

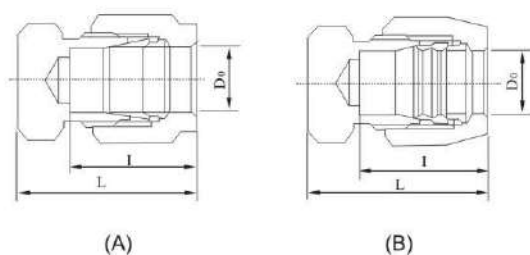

D ₀	L	l	代号 Code No
4	26	16	TKG1-26A-Φ4
5	26	16	TKG1-26A-Φ5
6	26	16	TKG1-26A-Φ6
8	32.5	20.5	TKG1-26A-Φ8
10	32.5	20.5	TKG1-26A-Φ10
12	36.5	23.5	TKG1-26A-Φ12
14	36.5	24.5	TKG1-26A-Φ14
16	39.5	25.5	TKG1-26B-Φ16
18	39.5	25.5	TKG1-26B-Φ18

TKG1-27 堵头 (二) TKG1-27 Ptug(2)

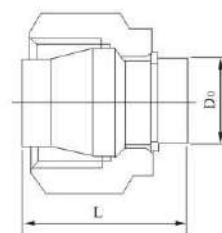

D ₀	L	代号 Code No
4	26	TKG1-27-Φ4
5	26	TKG1-27-Φ5
6	26	TKG1-27-Φ6
8	30.5	TKG1-27-Φ8
10	30.5	TKG1-27-Φ10
12	33.5	TKG1-27-Φ12
14	34.5	TKG1-27-Φ14
16	36.5	TKG1-27-Φ16
18	36.5	TKG1-27-Φ18

TKG1-28 卡套 TKG1-28 Cutting Sleeve

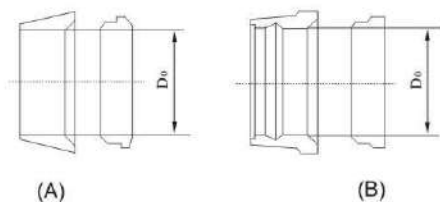

D ₀	代号 Code No
4	TKG1-28A-Φ4
5	TKG1-28A-Φ5
6	TKG1-28A-Φ6
8	TKG1-28A-Φ8
10	TKG1-28A-Φ10
12	TKG1-28A-Φ12
14	TKG1-28A-Φ14
16	TKG1-28B-Φ16
18	TKG1-28B-Φ18

TKG1-29 螺母 TKG1-29 Nut

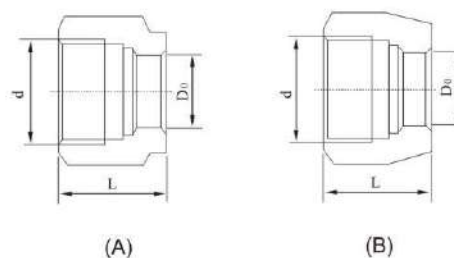

D ₀	d	L	代号 Code No
4	M10×1	16	TKG1-29A-M10×1-Φ4
5	M10×1	16	TKG1-29A-M10×1-Φ5
6	M12×1.25	18	TKG1-29A-M12×1.25-Φ6
8	M14×1.5	21	TKG1-29A-M14×1.5-Φ8
10	M16×1.5	22	TKG1-29A-M16×1.5-Φ10
12	M18×1.5	23	TKG1-29A-M18×1.5-Φ12
14	M20×1.5	23	TKG1-29A-M20×1.5-Φ14
16	M22×1.5	25	TKG1-29B-M22×1.5-Φ16
18	M24×1.5	25	TKG1-29B-M24×1.5-Φ18

TKG 1系列钢制单卡套式管接头

TKG1 Steel Tube Fitting of Single Ferrule

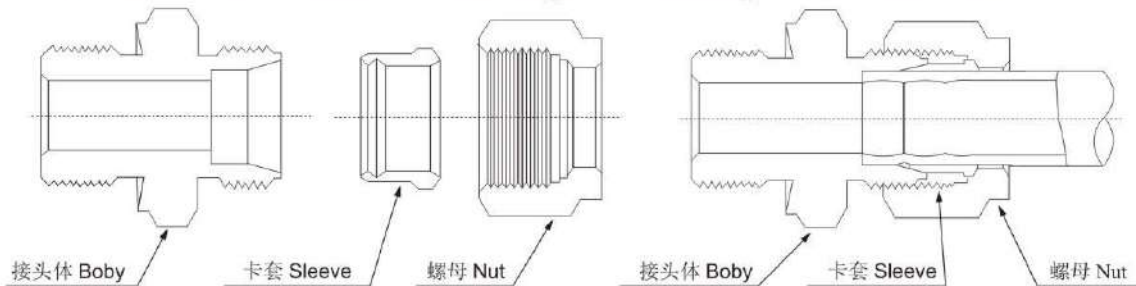

- 材料: 20、1Cr18Ni9Ti、316、316L
- Material: 20、1Cr18Ni9Ti、316、316L
- 公称压力: 16MPa、32MPa
- Pated Pressure: 16MPa、32Mpa

- 管径: $\Phi 4 \sim \Phi 42$
- Pipe Diameter: $\Phi 4 \sim \Phi 42$
- 终端螺纹可为M、G、ZG、PT、NPT等
- Extreme thread can be M、G、ZG、PT、NPT...

TKG1D-1 直通终端 (GB3733.1-83)	TKG1D-2 弯通终端 (GB3738.1-83)	TKG1D-3 三通终端 (GB3741.1-83)	TKG1D-4 压力表直通 (GB3751.1-83)	TKG1D-5 压力表弯通
TKG1D-6 压力表三通	TKG1D-7 直通中间 (GB3737.1-83)	TKG1D-8 弯通中间 (GB3740.1-83)	TKG1D-9 三通中间 (GB3745.1-83)	TKG1D-10 四通中间 (GB3746.1-83)
TKG1D-11 直通穿板 (GB3748.1-83)	TKG1D-12 弯通穿板 (GB3749.1-83)	TKG1D-13 直通终端长管 (GB3735.1-83)	TKG1D-14 铰接管 (GB3750.1-83)	TKG1D-15 焊接终端 (GB3747.1-83)
TKG1D-16 外套螺母 (GB3759.1-83)	TKG1D-17 卡套 (GB3764.1-83)	TKG1D-18 对接直通终端 (GB3754.1-83)	TKG1D-19 对接弯通终端 (GB3757.1-83)	TKG1D-20 对接直通 (GB3756.1-83)
TKG1D-21 对接螺母 (GB3760.1-83)	TKG1D-22 锥体环 (GB3761.1-83)	TKG1D-23 卡套式堵头	TKG1D-24 组合弯通 (GB3752.1-83)	TKG1D-25 组合三通 (GB3753.1-83)

TKG2 铜制气动管路接头 (铜管、尼龙管用)

TKG2 Copper Bayonet Joint for Use in Pneumatic Pipe (made of copper)

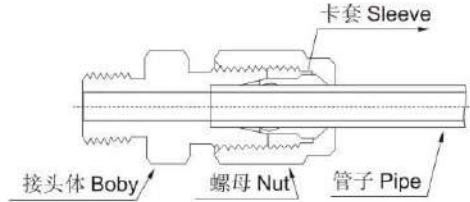
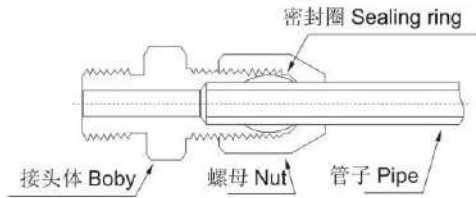

材料: H62 (表面镀铬)

- Material:H62(Crsurface Galvani-zation)
- 公称压力: 1.0MPa(密封圈式)1.6MPa(卡套式)
- Rated Pressure:1.0MPa(sealing Ring)1.6MPa(Sleeve)

- 管径 $\phi 6 \sim \phi 14$
- Pipe diameter: $\phi 6 \sim \phi 14$
- 终端螺纹可为M、G、ZG、PT、NPT
- Extreme thread can be M、G、ZG、PT、NPT

TKG2-1 直通终端接头 TKG2-1 Extreme Straight-through Sleeve

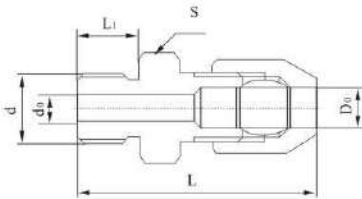

D ₀	d	d ₀	L	L ₁	S	D ₀	d	d ₀	L	L ₁	S
6	M10×1	4	34	9	14	8	ZG1/2"	6	42	15	27
6	M12×1	4	36	10	14	10	M14×1	7	38	12	19
6	M14×1.5	4	38	12	19	10	M16×1.5	8	38	12	19
6	M16×1.5	4	38	12	19	10	M18×1.5	8	40	15	24
6	M18×1.5	4	38	15	24	10	M20×1.5	8	42	15	27
6	M20×1.5	4	42	15	27	10	ZG1/2"	8	42	15	27
6	ZG1/2"	4	42	15	27	12	M16×1.5	10	38	12	19
8	M10×1	5	34	9	14	12	M18×1.5	10	40	15	24
8	M12×1	6	36	10	14	12	M20×1.5	10	42	15	27
8	M14×1.5	6	38	12	19	12	ZG1/2"	10	42	15	27
8	M16×1.5	6	38	15	19	14	M18×1.5	12	40	15	24
8	M18×1.5	6	38	15	24	14	M20×1.5	12	42	15	27
8	M20×1.5	6	42	15	27	14	ZG1/2"	12	42	15	27

TKG2-2 直通中间接头 TKG2-2 Straight-through Intermediate Sleeve

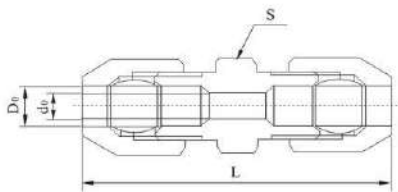

D ₀	d ₀	L	S
6	4	44	12
8	6	44	14
10	8	47	17
12	10	49	19
14	12	52	22

TKG2-3 直通穿板接头 TKG2-3 Straigh-through Through-board Sleeve

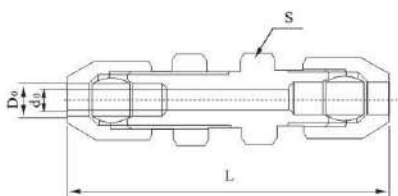

D ₀	d ₀	L	S
6	4	54	12
8	6	54	14
10	8	57	17
12	10	59	19
14	12	62	22

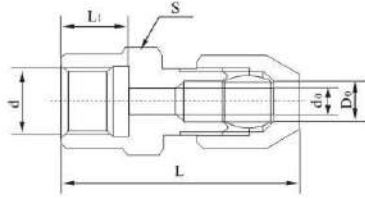
TKG2-4 压力表直通接头 TKG2-4 Manometer Straight-through Sleeve

D ₀	d	d ₀	L	L ₁	S	D ₀	d	d ₀	L	L ₁	S
6	M10×1	4	35	10	14	8	G1/2"	6	35	40	27
6	M14×1.5	4	39	13	19	10	M16×1.5	8	39	40	22
6	M16×1.5	4	39	13	22	10	M20×1.5	8	39	41	24
6	M20×1.5	4	40	13	24	10	G1/2"	8	40	41	27
6	G1/2"	4	40	13	27	12	M20×1.5	10	40	43	24
8	M14×1.5	6	39	13	19	12	G1/2"	10	39	43	27
8	M16×1.5	6	39	13	22	14	M20×1.5	12	39	45	24
8	M20×1.5	6	40	13	24	14	G1/2"	12	40	45	27

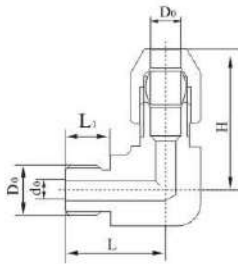
TKG2-5 弯通终端接头 TKG2-5 Extreme Elbow Pipe Connector

D ₀	d	d ₀	L	L ₁	H	D ₀	d	d ₀	L	L ₁	H
6	M10×1	4	20	9	26	10	M16×1.5	8	25	12	31
6	M16×1.5	4	23	12	30	10	ZG1/2"	8	28	15	32
6	G1/4"	4	22	11	28	12	M16×1.5	10	26	12	33
8	M10×1	6	21	9	26	12	ZG1/2"	10	29	15	34
8	M16×1.5	6	24	12	30	14	M16×1.5	12	27	12	33
8	ZG1/4"	6	23	11	28	14	ZG1/2"	12	30	15	34

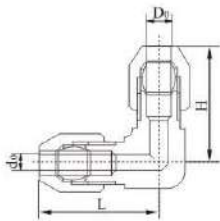
TKG2-6 弯通中间接头 TKG2-6 Elbow Pipe inter-mediate Connector

D ₀	d ₀	L	H
6	4	27	27
8	6	28	28
10	8	30	30
12	10	32	30
14	12	34	34

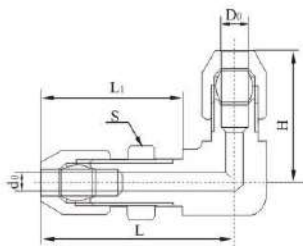
TKG2-7 弯通穿板接头 TKG2-7 Elbow Pipe Through-board Connector

D ₀	d ₀	L	L ₁	H	S
6	4	41	20	27	14
8	6	42	20	28	17
10	8	43	20	30	17
12	10	44	22	32	19
14	12	45	22	34	22

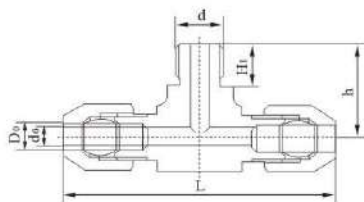
TKG2-8 三通终端接头 TKG2-8 Extreme T-pipe Connector

D ₀	d	d ₀	L	H	H ₁	D ₀	d	d ₀	L	H	H ₁
6	M10×1	4	52	20	9	10	M14×1.5	8	58	24	11
6	M14×1.5	4	56	22	11	10	M16×1.5	8	62	25	12
6	M16×1.5	4	60	23	12	10	ZG1/4"	8	58	24	11
6	ZG1/2"	4	56	22	11	12	M14×1.5	10	62	25	11
8	M10×1	6	52	21	9	12	M16×1.5	10	66	26	12
8	M14×1.5	6	56	23	11	12	ZG1/2"	10	68	29	15
8	M16×1.5	6	60	24	12	14	M16×1.5	12	66	27	12
8	ZG1/4"	6	56	23	11	14	ZG1/4"	12	68	30	15

TKG2-9 调节阀三通接头 TKG2-9 Regulating T-ping Connector

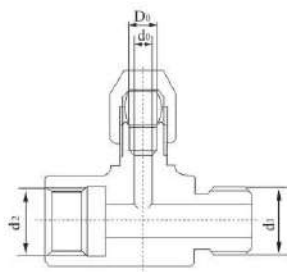

D ₀	d ₀	d ₁	d ₂
6	4	M14×1.5	M14×1.5
6	4	M16×1.5	M14×1.5
6	4	M16×1.5	M10×1.5
6	4	M16×1.5	M16×1.5
6	4	M16×1.5	M16×1.5
8	4	ZG1/4"	M12×1.5

D ₀	d ₀	d ₁	d ₂
6	4	ZG1/2"	M14×1.5
8	6	M16×1.5	M14×1.5
8	6	M16×1.5	M10×1
8	6	M16×1.5	M16×1.5
8	6	ZG1/4"	M14×1.5
8	6	ZG1/2"	M14×1.5

TKG2-10 压力表三通接头 TKG2-10 Manometer T-ping Connector

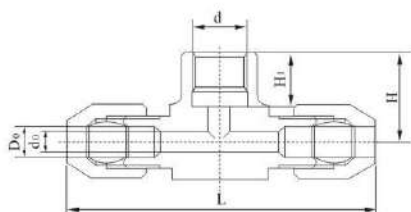

D ₀	d	d ₀	L	H	H ₁
6	M10×1	4	57	17	10
6	M14×1.5	4	60	21	13
6	M20×1.5	4	67	21	13
6	ZG1/8"	4	57	17	10
8	M10×1	6	57	17	10
8	M14×1.5	6	60	21	13
8	M20×1.5	6	67	21	13
8	ZG1/8"	6	57	17	10
10	M10×1	8	62	19	10

D ₀	d	d ₀	L	H	H ₁
10	M14×1.5	8	62	21	13
10	M20×1.5	8	62	21	13
10	G1/2"	8	62	22	13
12	M14×1.5	10	67	22	13
12	M20×1.5	10	73	22	13
12	G1/2"	10	67	22	13
14	M14×1.5	12	67	22	13
14	M20×1.5	12	73	22	13
14	G1/2"	12	67	22	13

三通中间接头 T-Pipe intermediate Connector	四通中间接头 Crossbar intermediate Connector	外套螺母 Outer Liner Nut	密封圈 Sealing Ring																																																																																				
TKG2-11	TKG2-12	TKG2-13	TKG2-14																																																																																				
<table border="1"> <thead> <tr> <th>D₀</th> <th>d₀</th> <th>L</th> <th>H</th> </tr> </thead> <tbody> <tr> <td>6</td> <td>4</td> <td>54</td> <td>27</td> </tr> <tr> <td>8</td> <td>6</td> <td>56</td> <td>28</td> </tr> <tr> <td>10</td> <td>8</td> <td>60</td> <td>30</td> </tr> <tr> <td>12</td> <td>10</td> <td>64</td> <td>32</td> </tr> <tr> <td>14</td> <td>12</td> <td>68</td> <td>34</td> </tr> </tbody> </table>	D ₀	d ₀	L	H	6	4	54	27	8	6	56	28	10	8	60	30	12	10	64	32	14	12	68	34	<table border="1"> <thead> <tr> <th>D₀</th> <th>d₀</th> <th>L</th> </tr> </thead> <tbody> <tr> <td>6</td> <td>4</td> <td>54</td> </tr> <tr> <td>8</td> <td>6</td> <td>56</td> </tr> <tr> <td>10</td> <td>8</td> <td>60</td> </tr> <tr> <td>12</td> <td>10</td> <td>64</td> </tr> <tr> <td>14</td> <td>12</td> <td>68</td> </tr> </tbody> </table>	D ₀	d ₀	L	6	4	54	8	6	56	10	8	60	12	10	64	14	12	68	<table border="1"> <thead> <tr> <th>D₀</th> <th>d</th> <th>L</th> <th>S</th> </tr> </thead> <tbody> <tr> <td>6</td> <td>M10×1</td> <td>15</td> <td>12</td> </tr> <tr> <td>8</td> <td>M12×1</td> <td>15</td> <td>14</td> </tr> <tr> <td>10</td> <td>M14×1</td> <td>17</td> <td>17</td> </tr> <tr> <td>12</td> <td>M16×1.5</td> <td>19</td> <td>19</td> </tr> <tr> <td>14</td> <td>M18×1.5</td> <td>19</td> <td>22</td> </tr> </tbody> </table>	D ₀	d	L	S	6	M10×1	15	12	8	M12×1	15	14	10	M14×1	17	17	12	M16×1.5	19	19	14	M18×1.5	19	22	<table border="1"> <thead> <tr> <th>D₀</th> <th>D</th> <th>L</th> </tr> </thead> <tbody> <tr> <td>6</td> <td>8</td> <td>7</td> </tr> <tr> <td>8</td> <td>10</td> <td>7</td> </tr> <tr> <td>10</td> <td>12</td> <td>7</td> </tr> <tr> <td>12</td> <td>14</td> <td>7</td> </tr> <tr> <td>14</td> <td>16</td> <td>7</td> </tr> </tbody> </table>	D ₀	D	L	6	8	7	8	10	7	10	12	7	12	14	7	14	16	7
D ₀	d ₀	L	H																																																																																				
6	4	54	27																																																																																				
8	6	56	28																																																																																				
10	8	60	30																																																																																				
12	10	64	32																																																																																				
14	12	68	34																																																																																				
D ₀	d ₀	L																																																																																					
6	4	54																																																																																					
8	6	56																																																																																					
10	8	60																																																																																					
12	10	64																																																																																					
14	12	68																																																																																					
D ₀	d	L	S																																																																																				
6	M10×1	15	12																																																																																				
8	M12×1	15	14																																																																																				
10	M14×1	17	17																																																																																				
12	M16×1.5	19	19																																																																																				
14	M18×1.5	19	22																																																																																				
D ₀	D	L																																																																																					
6	8	7																																																																																					
8	10	7																																																																																					
10	12	7																																																																																					
12	14	7																																																																																					
14	16	7																																																																																					

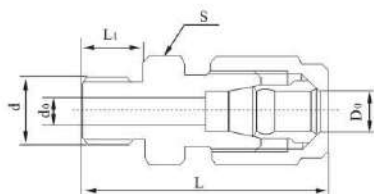
TKG2-15 直通终端接头 TKG2-15 Extreme Straight-through Sleeve

D ₀	d	d ₀	L	L ₁	S
6	M10×1	4	36	9	14
6	M12×1	4	38	10	17
6	M14×1.5	4	40	12	19
6	M16×1.5	4	40	12	22
6	M18×1.5	4	40	15	24
6	M20×1.5	4	44	15	27
6	ZG1/2"	4	44	15	27
8	M10×1	6	36	9	14
8	M12×1	6	28	10	17
8	M14×1.5	6	40	12	19
8	M16×1.5	6	40	15	22
8	M18×1.5	6	40	15	24
8	M20×1.5	6	44	15	27

D ₀	d	d ₀	L	L ₁	S
8	ZG1/2"	6	46	15	27
10	M14×1.5	8	42	12	19
10	M16×1.5	8	42	12	22
10	M18×1.5	8	44	15	24
10	M20×1.5	8	46	15	27
10	ZG1/2"	8	46	15	27
12	M16×1.5	10	42	12	22
12	M18×1.5	10	44	15	24
12	M20×1.5	10	46	15	27
12	ZG1/2"	10	46	15	27
14	M18×1.5	12	44	15	24
14	M20×1.5	12	46	15	27
14	ZG1/2"	12	46	15	27

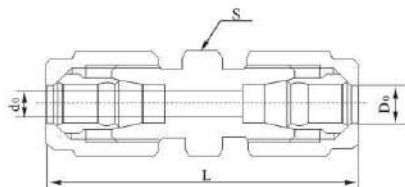
TKG2-16 直通中间接头 TKG2-16 Straight-through Intermediate Sleeve

D ₀	d ₀	L	S
6	4	48	14
8	6	48	17
10	8	51	19
12	10	53	22
14	12	55	24

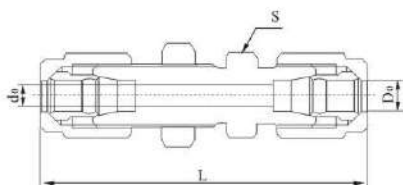
TKG2-17 直通穿板接头 TKG2-17 Straight-through Through-board Sleeve

D ₀	d ₀	L	S
6	4	58	14
8	6	58	17
10	8	61	19
12	10	63	22
14	12	65	24

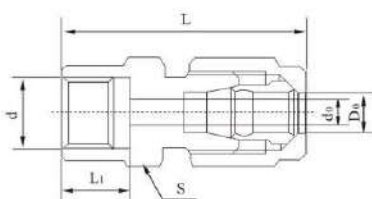
TKG2-18 压力表直通接头 TKG2-18 Manometer Straight-through Sleeve

D ₀	d	d ₀	L	L ₁	H
6	M10×1	4	37	10	14
6	M14×1.5	4	41	13	19
6	M16×1.5	4	41	13	22
6	M20×1.5	4	42	13	24
6	ZG1/2"	4	42	13	27
8	M14×1.5	6	41	13	19
8	M16×1.5	6	41	13	22
8	M20×1.5	6	42	13	24

D ₀	d	d ₀	L	L ₁	H
8	G1/2"	6	42	13	27
10	M16×1.5	8	42	13	22
10	M20×1.5	8	43	13	24
10	G1/2"	8	43	13	27
12	M20×1.5	10	45	13	24
12	G1/2"	10	45	13	27
14	M20×1.5	12	47	13	24
14	G1/2"	12	47	13	27

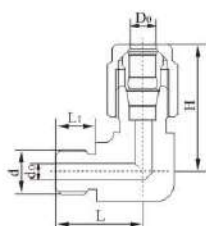
TKG2-19 弯通终端接头 TKG2-19 Extreme Elbow Pipe Connector

D ₀	d	d ₀	L	L ₁	S
6	M10×1	4	20	9	28
6	M16×1.5	4	23	12	32
6	ZG1/4"	4	22	11	30
8	M10×1	6	21	9	28
8	M16×1.5	6	24	12	32
8	ZG1/4"	6	23	11	30

D ₀	d	d ₀	L	L ₁	S
10	M16×1.5	8	25	12	33
10	ZG1/2"	8	28	15	35
12	M16×1.5	10	26	12	35
12	ZG1/2"	10	29	15	36
14	M16×1.5	12	27	12	35
14	ZG1/2"	12	30	15	36

TKG2-20 弯通中间接头 TKG2-20 Elbow Pipe inter-mediate Connector

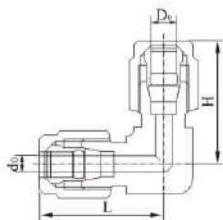

D ₀	d ₀	L	H
6	4	29	29
8	6	30	30
10	8	32	32
12	10	34	34
14	12	36	36

TKG2-21 弯通穿板接头 TKG2-21 Elbow Pipe Through-board Connector

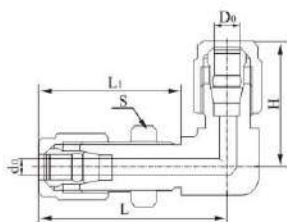

D ₀	d ₀	L	L ₁	H	S
6	4	43	20	29	14
8	6	44	20	30	17
10	8	45	20	32	19
12	10	46	22	34	22
14	12	47	22	36	24

TKG2-22 三通终端接头 TKG2-22 Extreme T-Pipe Connector

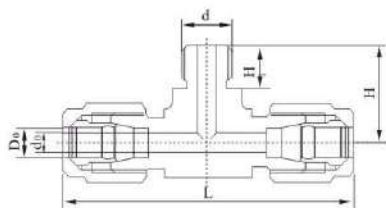

D ₀	d	d ₀	L	H	H ₁	D ₀	d	d ₀	L	H	H ₁
6	M10×1	4	56	20	9	10	M14×1.5	8	62	24	11
6	M14×1.5	4	60	22	11	10	M16×1.5	8	66	25	12
6	M16×1.5	4	64	23	12	10	ZG1/4"	8	62	24	11
6	ZG1/4"	4	60	22	11	12	M14×1.5	10	66	25	11
8	M10×1	6	56	21	9	12	M16×1.5	10	70	26	12
8	M14×1.5	6	60	23	11	12	ZG1/2"	10	72	29	15
8	M16×1.5	6	64	24	12	14	M16×1.5	12	70	27	12
8	ZG1/4"	6	60	23	11	14	ZG1/2"	12	72	30	15

三通中间接头 T-Pipe intermediate	外套螺母 Outer Liner Nut	卡套 Cutting Sleeve	薄壁管衬套 Thin Wall Pipe Bush																																																																																								
TKG2-23	TKG2-24	TKG2-25	TKG2-26																																																																																								
<table border="1"> <thead> <tr> <th>D₀</th> <th>d₀</th> <th>L</th> <th>H</th> </tr> </thead> <tbody> <tr> <td>6</td> <td>4</td> <td>58</td> <td>29</td> </tr> <tr> <td>8</td> <td>6</td> <td>60</td> <td>30</td> </tr> <tr> <td>10</td> <td>8</td> <td>64</td> <td>32</td> </tr> <tr> <td>12</td> <td>10</td> <td>68</td> <td>34</td> </tr> <tr> <td>14</td> <td>12</td> <td>72</td> <td>36</td> </tr> </tbody> </table>	D ₀	d ₀	L	H	6	4	58	29	8	6	60	30	10	8	64	32	12	10	68	34	14	12	72	36	<table border="1"> <thead> <tr> <th>D₀</th> <th>d</th> <th>L</th> <th>S</th> </tr> </thead> <tbody> <tr> <td>6</td> <td>M12×1</td> <td>15</td> <td>14</td> </tr> <tr> <td>8</td> <td>M14×1</td> <td>16</td> <td>17</td> </tr> <tr> <td>10</td> <td>M16×1.5</td> <td>17</td> <td>19</td> </tr> <tr> <td>12</td> <td>M18×1.5</td> <td>18</td> <td>22</td> </tr> <tr> <td>14</td> <td>M20×1.5</td> <td>19</td> <td>24</td> </tr> </tbody> </table>	D ₀	d	L	S	6	M12×1	15	14	8	M14×1	16	17	10	M16×1.5	17	19	12	M18×1.5	18	22	14	M20×1.5	19	24	<table border="1"> <thead> <tr> <th>D₀</th> <th>L</th> </tr> </thead> <tbody> <tr> <td>6</td> <td>8</td> </tr> <tr> <td>8</td> <td>9</td> </tr> <tr> <td>10</td> <td>10</td> </tr> <tr> <td>12</td> <td>10</td> </tr> <tr> <td>14</td> <td>10</td> </tr> </tbody> </table>	D ₀	L	6	8	8	9	10	10	12	10	14	10	<table border="1"> <thead> <tr> <th>d</th> <th>L</th> <th>d</th> <th>L</th> </tr> </thead> <tbody> <tr> <td>4</td> <td>16</td> <td>8.5</td> <td>18</td> </tr> <tr> <td>4.5</td> <td>16</td> <td>10</td> <td>18</td> </tr> <tr> <td>5</td> <td>16</td> <td>10.5</td> <td>18</td> </tr> <tr> <td>6</td> <td>17</td> <td>12</td> <td>20</td> </tr> <tr> <td>6.5</td> <td>17</td> <td>14</td> <td>20</td> </tr> <tr> <td>8</td> <td>18</td> <td>15</td> <td>20</td> </tr> </tbody> </table>	d	L	d	L	4	16	8.5	18	4.5	16	10	18	5	16	10.5	18	6	17	12	20	6.5	17	14	20	8	18	15	20
D ₀	d ₀	L	H																																																																																								
6	4	58	29																																																																																								
8	6	60	30																																																																																								
10	8	64	32																																																																																								
12	10	68	34																																																																																								
14	12	72	36																																																																																								
D ₀	d	L	S																																																																																								
6	M12×1	15	14																																																																																								
8	M14×1	16	17																																																																																								
10	M16×1.5	17	19																																																																																								
12	M18×1.5	18	22																																																																																								
14	M20×1.5	19	24																																																																																								
D ₀	L																																																																																										
6	8																																																																																										
8	9																																																																																										
10	10																																																																																										
12	10																																																																																										
14	10																																																																																										
d	L	d	L																																																																																								
4	16	8.5	18																																																																																								
4.5	16	10	18																																																																																								
5	16	10.5	18																																																																																								
6	17	12	20																																																																																								
6.5	17	14	20																																																																																								
8	18	15	20																																																																																								

TKG3 铜制气动管路接头 (塑料管用)

TKG3 Copper Preumatic Piping Connector (for piastic pipe)

技术特性

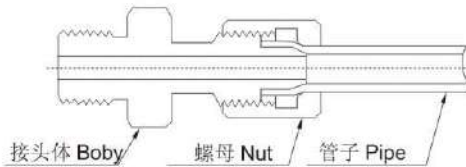

配管外径 D ₀	公称压力 PN	公称通径 PN	适用介质 Med	适用温度 Temp	制造材料 materat
mm	Mpa	mm			
6	1	3	非腐蚀性 气体 Non-Corrosive Gas	常 温 Normal Temp Norm	H62表面镀铬 H62(Cr surface Galvanization)
8		5			

TKG3-1直通终端接头 (一) TKG3-1 Extreme Straight Through Sleeve(1)

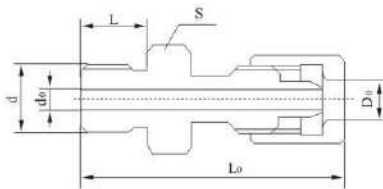

D ₀	d	d ₀	L ₀	L	S	D ₀	d	d ₀	L ₀	L	S
6	M8×1	3	36	9	12	8	M8×1	5	36	9	14
6	M10×1	3	36	9	14	8	M10×1	5	36	9	14
6	M14×1.5	3	40	12	17	8	M14×1.5	5	40	12	17
6	M16×1.5	3	40	12	19	8	M16×1.5	5	40	12	19
6	M20×1.5	3	44	14	24	8	M20×1.5	5	44	14	24
6	ZG1/8"	3	36	9	12	8	ZG1/8"	5	36	9	14
6	ZG1/4"	3	38	11	14	8	ZG1/4"	5	38	11	14
6	ZG1/2"	3	44	15	22	8	ZG1/2"	5	44	15	22

TKG3-2直通终端接头 (二) TKG3-2 Extreme Straight-through Sleeve(2)

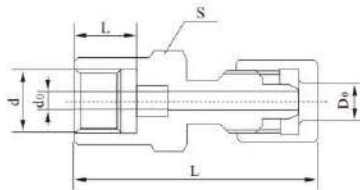

D ₀	d	d ₀	L ₀	L	S	D ₀	d	d ₀	L ₀	L	S
6	M10×1	3	39	10	14	8	M10×1	5	39	10	14
6	M14×1.5	3	40	13	19	8	M14×1.5	5	40	13	19
6	M16×1.5	3	41	13	22	8	M16×1.5	5	41	13	22
6	M20×1.5	3	41	13	24	8	M20×1.5	5	41	13	24
6	ZG1/4"	3	40	13	17	8	ZG1/4"	5	40	13	17
6	G1/2"	3	41	13	24	8	G1/2"	5	41	13	22

TKG3-3直通中间接头 TKG3-3 Straight-throughintermediate Connector

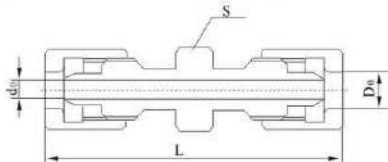

D ₀	d	L	S
6	3	45	12
8	5	45	14

TKG3-4 直通穿板接头 TKG3-4 Straight Through Through-board Connector

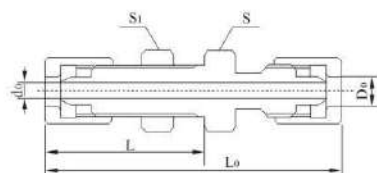

D ₀	d ₀	L ₀	L	S	S1
6	3	58	31	14	17
8	5	58	31	17	17

TKG3-5弯通终端接头 TKG3-5 Elbow Pipe Straight-through Sleeve

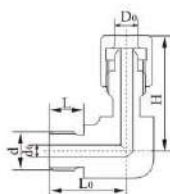

D ₀	d	d ₀	L ₀	L	H	D ₀	d	d ₀	L ₀	L	H
6	M10×1	3	20	9	29	8	M10×1	5	20	9	29
6	M14×1.5	3	23	12	32	8	M14×1.5	5	23	12	32
6	M20×1.5	3	25	14	25	8	M20×1.5	5	25	14	35
6	ZG1/8"	3	20	9	29	8	ZG1/8"	5	20	9	29
6	ZG1/4"	3	22	11	29	8	ZG1/4"	5	22	11	29
6	ZG1/2"	3	26	15	35	8	ZG1/2"	5	26	15	35

TKG3-6 弯通穿板接头 TKG3-6 Elbow Pipe Through-board Connector

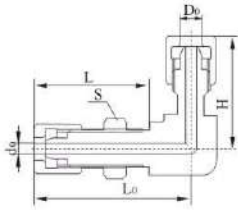

D ₀	d ₀	L ₀	L	H	S
6	3	42	31	30	14
8	5	42	31	30	17

标记示例: HYG3-6-Φ6 code example:HYG3-6-Φ6

TKG3-7 三通中间接头 TKG3-7 T-Pipe Intermediate Connector

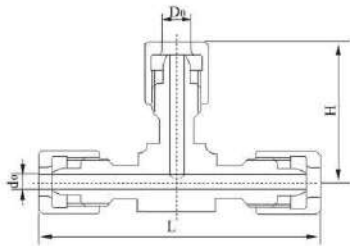

D ₀	d ₀	L	H
6	3	58	29
8	5	60	30

标记示例: HYG3-7-Φ6 code example:HYG3-7-Φ6

TKG3-8 压力表三通接头 TKG3-8 Manometer T-Pipe Connector

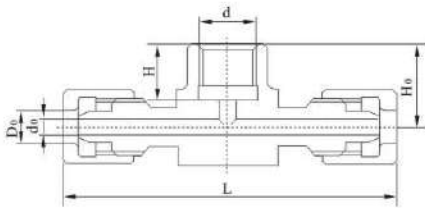

D ₀	d	d ₀	L	H ₀	H
6	M10×1	3	61	16	10
6	M14×1.5	3	64	19	13
6	G1/4"	3	64	19	13
8	M10×1	5	61	16	10
8	M14×1.5	5	64	19	13
8	G1/4"	5	64	19	13

TKG3-9 三通终端接头 TKG3-9 Extreme T-Pipe Connector

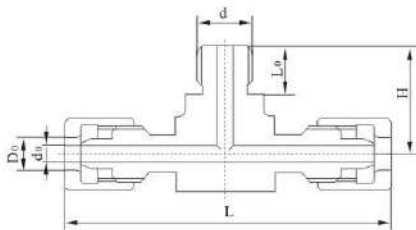

D ₀	d	d ₀	L ₀	L	H	D ₀	d	d ₀	L ₀	L	H
6	M10×1	3	60	9	20	8	M10×1	5	60	9	20
6	M14×1.5	3	63	12	23	8	M14×1.5	5	63	12	23
6	M20×1.5	3	65	12	23	8	M16×1.5	5	65	12	23
6	ZG1/8"	3	60	9	20	8	ZG1/8"	5	60	9	30
6	ZG1/4"	3	60	11	22	8	ZG1/4"	5	60	11	22
6	ZG1/2"	3	65	15	24	8	ZG3/8	5	65	12	24

标记示例: HYG3-9-M10×1-Φ6 code example:HYG3-9-M10×1-Φ6

TKG3-10 螺母 TKG3-10 Nut

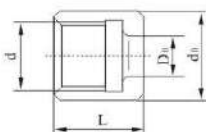

D ₀	d	d ₁	L
6	M10×1	13	13
5	M12×1	16	13

TKG4系列扩口式管接头 *TKG4 Flared Fitting*

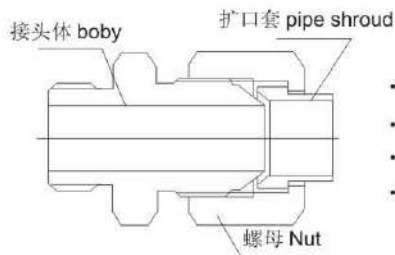

- 材料: 20、1Cr18Ni9Ti、316、316L
- 材料: 120、1Cr18Ni9Ti、316、316L
- 公称压力: 16MPa
- Rated Pressure: 16MPa
- 管径: D0: $\phi 4 \sim \phi 34$
- Pipe Diameter: $\phi 4 \sim \phi 34$
- 终端螺纹旋可为M、G、ZG、PT、NPT等。
- Extreme thread can be M、G、ZG、PT、NPT...

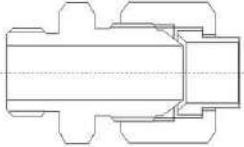
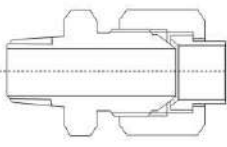
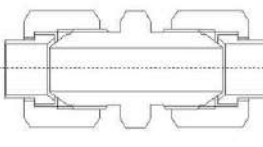
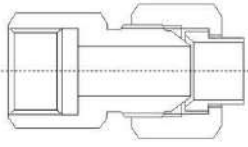
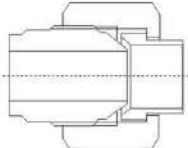
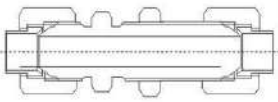
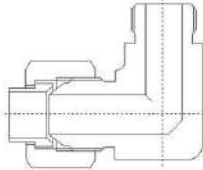
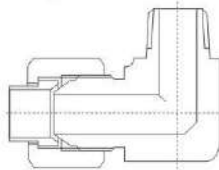
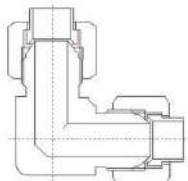
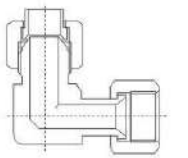
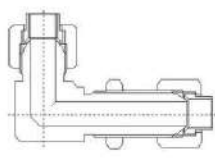
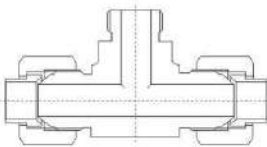
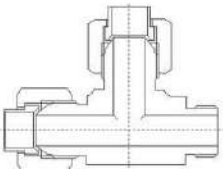
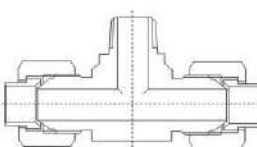
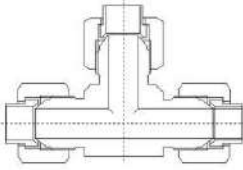
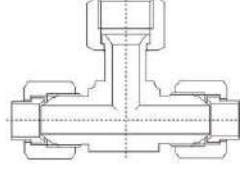
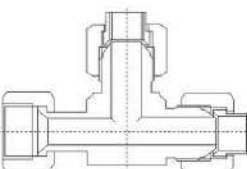
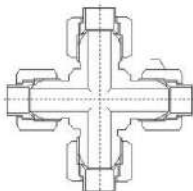
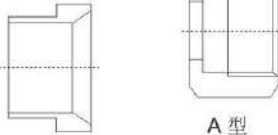
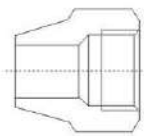
TKG4-1 直通终端接头 TKG4-1 Extreme Straight-through Sleeve 	TKG4-2 直通终端锥管接头 TKG4-2 Extreme Straight-through connector for Conical Pipe 	TKG4-3 直通中间接头 TKG4-3 Straight-through Sleeve 	TKG4-4 压力表直通接头 TKG4-4 Manometer Straight Sleeve 
TKG4-5 焊接管接头 TKG4-5 Welding Sleeve 	TKG4-6 直通穿板接头 TKG4-6 Wall-Separating Straight-through Sleeve 	TKG4-7 弯通终端接头 TKG4-7 Extreme Right-angle Pipe Connector 	TKG4-8 弯通终端锥管接头 TKG4-8 Extreme Right-angle Connector for Conical Pipe 
TKG4-9 弯通中间接头 TKG4-9 Right-angle Pipe Connector 	TKG4-10 组合弯通接头 TKG4-10 Combined Straight-through Pipe Connector 	TKG4-11 弯通穿板接头 TKG4-11 Wall-Separating Right-angle Pipe Connector 	TKG4-12 三通终端接头 TKG4-12 Extreme T-pipe Connector(1) 
TKG4-13 三通终端接头(二) TKG4-13 Extreme T-Pipe Connector(2) 	TKG4-14 三通终端锥管接头 TKG4-14 Extreme T-Pipe Connector for Conical Pipe 	TKG4-15 三通中间接头 TKG4-15 T-Pipe Connector 	TKG4-16 组合三通接头(一) TKG4-16 Combined T-Pipe Connector 
TKG4-17 组合三通接头(二) TKG4-17 Combined T-Pipe Connector 	TKG4-18 四通中间接头 TKG4-18 Crossbar Connector 	TKG4-19 管套 TKG4-19 Pipe Shroud  <p style="text-align: center;">A 型</p>	TKG4-20 螺母 TKG4-20 Type A Sleeve Nut  <p style="text-align: center;">B 型</p>

TKG5 焊接式管接头

TKG5 Welding pipe Connector

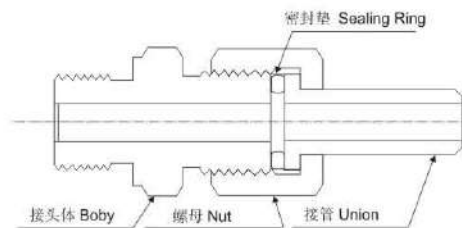
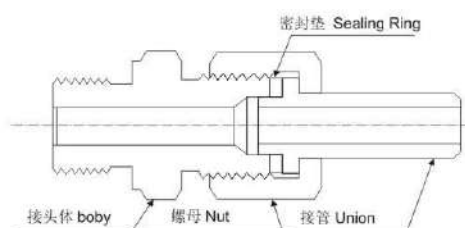

- 材料: 20、35、1Cr18Ni9Ti、316、316L
- 终端螺纹可为M、G、ZG、PT、NPT等
- 管位: $\Phi 6\sim\Phi 50$

- Material: 20、35、1Cr18Ni9Ti、316、316L
- Extreme thread can be M、G、ZG、PT、NPT……
- pipe diameter: $\Phi 6\sim\Phi 50$

TKG5-1 直通终端接头

TKG5-1 Extreme Straight-through Sleeve

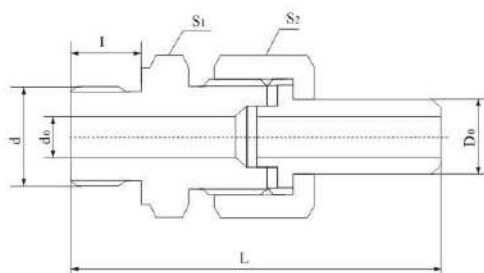

d	D ₀	d ₀	L	l	S ₁	S ₂	代号 Code
M10×1	6	3	49	9	14	17	TKG5-1-M10×1-Φ6
M10×1	10	4	55	9	17	19	TKG5-1-M10×1-Φ10
M14×1.5	10	6	59	12	19	19	TKG5-1-M14×1.5-Φ10
M14×1.5	14	8	66	12	24	27	TKG5-1-M14×1.5-Φ14
M18×1.5	14	10	70	14	27	27	TKG5-1-M18×1.5-Φ14
M18×1.5	18	10	78	14	30	32	TKG5-1-M18×1.5-Φ18
M22×1.5	18	12	78	14	32	32	TKG5-1-M22×1.5-Φ18
M22×1.5	22	12	79	14	32	36	TKG5-1-M22×1.5-Φ22
M27×1.5	22	15	83	16	36	36	TKG5-1-M27×1.2-Φ22
M27×1.5	28	17	88	16	41	41	TKG5-1-M27×1.2-Φ28
M33×2	28	20	88	16	41	41	TKG5-1-M33×2-Φ28
M33×2	34	22	95	16	46	50	TKG5-1-M33×2-Φ34
M42×2	34	25	101	18	55	50	TKG5-1-M42×2-Φ34
M42×2	42	28	105	18	55	60	TKG5-1-M42×2-Φ42
M48×2	42	32	107	20	60	60	TKG5-1-M48×2-Φ42
M48×2	50	40	115	20	65	70	TKG5-1-M48×2-Φ50
M10×1	6	3	81	41	14	17	TKG5-1-M10×1-Φ6
M10×1	10	4	90	44	17	19	TKG5-1-M10×1-Φ10
M14×1.5	10	6	94	47	19	19	TKG5-1-M14×1.5-Φ10
M14×1.5	14	8	103	55	24	27	TKG5-1-M14×1.5-Φ14
M18×1.5	14	10	113	57	27	27	TKG5-1-M18×1.5-Φ14
M18×1.5	18	10	121	59	30	32	TKG5-1-M18×1.5-Φ18
M22×1.5	18	12	121	59	32	32	TKG5-1-M22×1.5-Φ18
M22×1.5	22	12	126	60	32	36	TKG5-1-M22×1.5-Φ22
M27×2	22	15	130	64	36	36	TKG5-1-M27×2-Φ22
M27×2	28	17	142	70	41	41	TKG5-1-M27×2-Φ28
M33×2	28	20	142	70	41	41	TKG5-1-M33×2-Φ28
M33×2	34	22	160	81	46	50	TKG5-1-M33×2-Φ34
M42×2	34	25	166	83	55	50	TKG5-1-M42×2-Φ34
M42×2	42	28	174	90	55	60	TKG5-1-M42×2-Φ42
M48×2	42	32	181	92	60	60	TKG5-1-M48×2-Φ42
M48×2	50	40	193	98	65	70	TKG5-1-M48×2-Φ50

TKG5-2 直通终端锥管接头

TKG5-2 Extreme Straight-through Connector for Conical Pipe

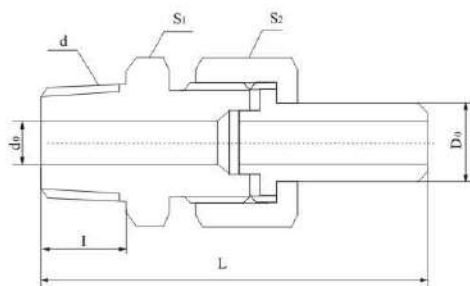

d	D ₀	d ₀	L	l	S ₁	S ₂	代号 Code
Z1/8"	10	6	56	9	19	19	TKG5-2-Z 1/8"-Φ10
Z1/4"	14	8	65	11	24	27	TKG5-2-Z 1/4"-Φ14
Z3/8"	18	10	72	12	30	32	TKG5-2-Z 3/8"-Φ18
Z1/2"	22	15	79	15	36	36	TKG5-2-Z 1/2"-Φ22
Z3/4"	28	20	86	17	41	41	TKG5-2-Z 3/4"-Φ28
Z1"	34	25	99	19	50	50	TKG5-2-Z1"-Φ34
Z1 1/4"	42	32	108	22	60	60	TKG5-2-Z1 1/4"-Φ42
Z1 1/2"	50	40	118	23	65	70	TKG5-2-Z1 1/2"-Φ50
Z1/8"	10	6	73	25	19	19	TKG5-2J-Z 1/8"-Φ10
Z1/4"	14	8	90	29	24	27	TKG5-2J-Z 1/4"-Φ14
Z3/8"	18	10	95	33	30	32	TKG5-2J-Z 3/8"-Φ18
Z1/2"	22	15	100	35	36	36	TKG5-2J-Z 1/2"-Φ22
Z3/4"	28	20	110	39	41	41	TKG5-2J-Z 3/4"-Φ28
Z1"	34	25	128	48	50	50	TKG5-2J-Z1"-Φ34
Z1 "	42	32	139	52	60	60	TKG5-2J-Z1 1/4"-Φ42
Z1 1/2"	50	40	151	56	65	70	TKG5-2J-Z1 1/2"-Φ50

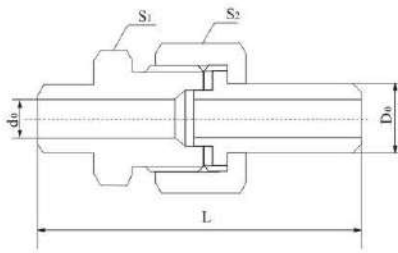
TKG5-3 直通中间接头 TKG5-3 Straight-through Intgermediate Connector

D ₀	d ₀	L	S ₁	S ₂	代号 Code
6	3	48	14	17	TKG5-3-Φ6
10	6	54	19	19	TKG5-3-Φ10
14	8	66	24	27	TKG5-3-Φ14
18	10	72	32	32	TKG5-3-Φ18
22	15	77	36	36	TKG5-3-Φ22
28	20	85	41	41	TKG5-3-Φ28
34	25	96	50	50	TKG5-3-Φ34
42	32	106	60	60	TKG5-3-Φ42
50	40	115	70	70	TKG5-3-Φ50

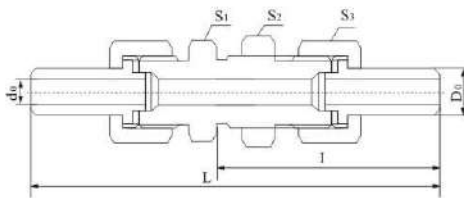
TKG5-4 直通穿板接头 TKG5-4 Through-board Straight Through Sleeve

D ₀	d ₀	L	l	S ₁	S ₂	S ₃	代号 Code
6	3	98	58	17	17	17	TKG5-4-Φ6
10	6	110	64	19	22	19	TKG5-4-Φ10
14	8	125	71	27	30	27	TKG5-4-Φ14
18	10	137	76	32	36	32	TKG5-4-Φ18
22	15	145	80	36	41	36	TKG5-4-Φ22
28	20	155	85	41	50	41	TKG5-4-Φ28
34	25	172	92	50	55	50	TKG5-4-Φ34
42	32	186	100	60	65	60	TKG5-4-Φ42
50	40	202	109	70	75	70	TKG5-4-Φ50

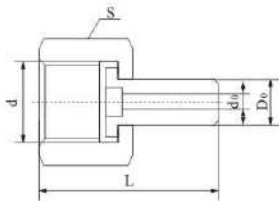
TKG5-5 压力表直通接头 TKG5-5 Manometer Straight through Sleeve

d	D ₀	d ₀	L	S	代号 Code
M14×1.5	6	3	28	17	TKG5-5-M14×1.5-Φ6
M20×1.5	14	8	38	27	TKG5-5-M20×1.5-Φ14
G1/2"	14	8	38	27	TKG5-5 1/2"-Φ14

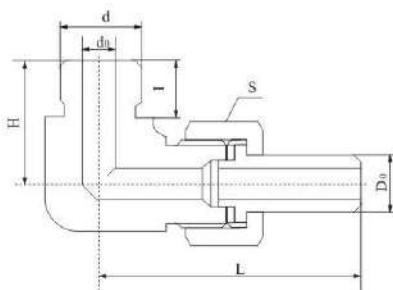
TKG5-6 弯通终端接头 TKG5-6 Extreme Elbow Pipe Connector

d	D ₀	d ₀	H	l	L	S	代号 Code
M10×1	10	6	20	9	50	19	TKG5-6-M10×1-Φ10
M14×1.5	14	8	23	12	60	27	TKG5-6-M14×1.5-Φ14
M18×1.5	18	10	30	14	68	32	TKG5-6-M18×1.5-Φ18
M22×1.5	22	15	35	14	71	36	TKG5-6-M22×1.5-Φ22
M27×2	28	20	37	16	82	41	TKG5-6-M27×2-Φ28
M33×2	34	25	40	16	92	50	TKG5-6-M33×2-Φ34
M42×2	42	32	47	18	103	60	TKG5-6-M42×2-Φ42
M48×2	50	40	54	20	115	70	TKG5-6-M48×2-Φ50

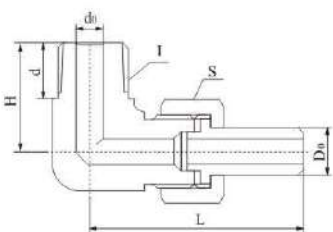
TKG5-7 弯通终端锥管接头 TKG5-7 Conical Pipe Connector for Elbow Pipe Extreme

d	D ₀	d ₀	H	l	L	S	代号 Code
Z1/8"	10	6	20	9	51	19	TKG5-7-Z 1/8"-Φ10
Z1/4"	14	8	22	11	60	27	TKG5-7-Z 1/4"-Φ14
Z3/8"	18	10	28	12	68	32	TKG5-7-Z 3/8"-Φ18
Z1/2"	22	15	36	15	73	36	TKG5-7-Z 1/2"-Φ22
Z3/4"	28	20	38	17	82	41	TKG5-7-Z 3/4"-Φ28
Z1"	34	25	43	19	94	50	TKG5-7-Z1"-Φ34
Z1 1/4"	42	32	51	22	105	60	TKG5-7-Z1 1/4"-Φ42
Z1 1/2"	50	40	57	23	115	70	TKG5-7-Z1 1/2"-Φ50

TKG5-8 弯通中间接头 TKG5-8 Elbow Pipe Intermediate Connector

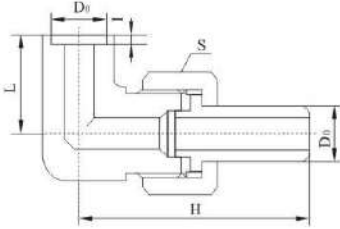

D_0	D_0'	L	I	H	S	代号 Code
6	6	17	2	40	17	TKG5-8-Φ6
10	10	20	2	47	19	TKG5-8-Φ10
14	14	25	2	57	27	TKG5-8-Φ14
18	18	29	2	66	32	TKG5-8-Φ18
22	22	32	2	69	36	TKG5-8-Φ22
28	28	36	2	77	41	TKG5-8-Φ28
34	34	41	2	87	50	TKG5-8-Φ34
42	42	48	3	98	60	TKG5-8-Φ42
50	50	55	3	109	70	TKG5-8-Φ50

TKG5-9 弯通穿板接头 TKG5-9 Elbow Pipe through-board Connector

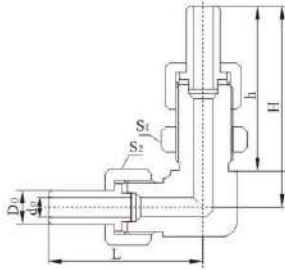

D_0	d_0	L	H	h	S_1	S_2	代号 Code
6	3	43	68	57	17	17	TKG5-9-Φ6
10	6	51	76	63	22	19	TKG5-9-Φ10
14	8	59	88	70	30	27	TKG5-9-Φ14
18	10	67	95	75	36	32	TKG5-9-Φ18
22	15	71	103	79	41	36	TKG5-9-Φ22
28	20	79	111	84	50	41	TKG5-9-Φ28
34	25	90	122	91	55	50	TKG5-9-Φ34
42	32	100	137	100	65	60	TKG5-9-Φ42
50	40	110	150	108	75	70	TKG5-9-Φ50

TKG5-10 三通中间接头 TKG5-10 T-pipe Intermediate Connector

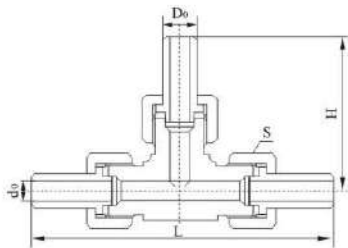

D_0	d_0	L	H	S	代号 Code
6	3	82	41	17	TKG5-10-Φ6
10	6	96	48	19	TKG5-10-Φ10
14	8	116	58	27	TKG5-10-Φ14
18	10	132	66	32	TKG5-10-Φ18
22	15	138	69	36	TKG5-10-Φ22
28	20	156	78	41	TKG5-10-Φ28
34	25	176	88	50	TKG5-10-Φ34
42	32	195	99	60	TKG5-10-Φ42
50	40	218	109	70	TKG5-10-Φ50

TKG5-11 四通中间接头 TKG5-11 Corssbar Intermediate Connector

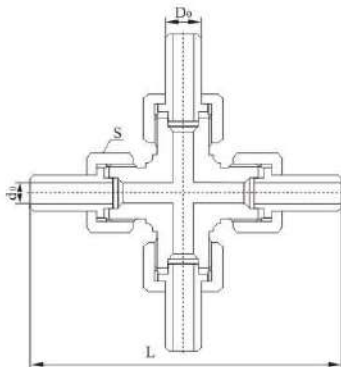

D_0	d_0	L	S	代号 Code
6	3	82	17	TKG5-11-Φ6
10	6	96	19	TKG5-11-Φ10
14	8	116	27	TKG5-11-Φ14
18	10	132	32	TKG5-11-Φ18
22	15	138	36	TKG5-11-Φ22
28	20	156	41	TKG5-11-Φ28
34	25	176	50	TKG5-11-Φ34
42	32	195	60	TKG5-11-Φ42
50	40	218	70	TKG5-11-Φ50

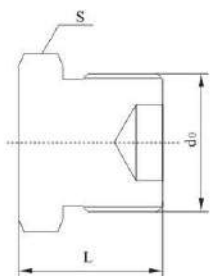
TKG5-12 堵头 TKG5-12 Plug

d_0	L	S	代号 Code
M12×1.25	18	14	TKG5-12-M12×1.25
M16×1.5	20	17	TKG5-12-M16×1.5
M22×1.5	23	24	TKG5-12-M22×1.5
M27×1.5	25	30	TKG5-12-M27×1.5
M30×1.5	27	32	TKG5-12-M30×1.5
M36×2	31	41	TKG5-12-M36×2
M42×2	35	46	TKG5-12-M42×2
M52×2	41	55	TKG5-12-M52×2
M60×2	46	65	TKG5-12-M60×2

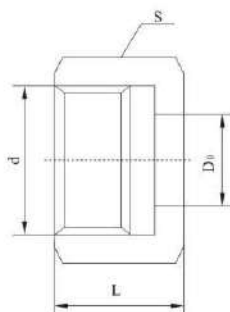
TKG5-13 螺母 TKG5-13 Nut

d	D_0	L	S	代号 Code
M12×1.25	6	12	17	TKG5-13-M12×1.25
M16×1.5	10	14	19	TKG5-13-M16×1.5
M22×1.5	14	17	27	TKG5-13-M22×1.5
M27×1.5	18	20	32	TKG5-13-M27×1.5
M30×1.5	22	21	36	TKG5-13-M30×1.5
M36×2	28	22	41	TKG5-13-M36×2
M42×2	34	26	50	TKG5-13-M42×2
M52×2	42	28	60	TKG5-13-M52×2
M60×2	50	30	70	TKG5-13-M60×2

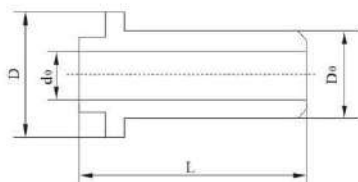
TKG5-14 接管 TKG5-14 Connecting Pipe

D_0	d_0	D	L	代号 Code
6	3	10	25	TKG5-14-Φ6
10	6	14	29	TKG5-14-Φ10
14	8	20	33	TKG5-14-Φ14
18	10	24	37	TKG5-14-Φ18
22	15	27	38	TKG5-14-Φ22
28	20	33	41	TKG5-14-Φ28
34	25	39	44	TKG5-14-Φ34
42	32	49	46	TKG5-14-Φ42
50	40	57	50	TKG5-14-Φ50

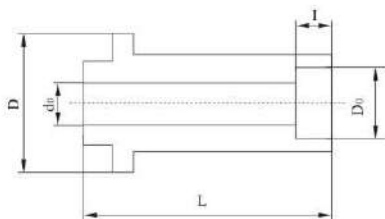
TKG5-15 变径接管 TKG5-15 Flexible Disconnecting Pipe

D_0	d_0	D	L	l	代号 Code
6	3	14	29	5	TKG5-15-Φ6
10	6	20	33	5	TKG5-15-Φ10
14	8	24	37	5	TKG5-15-Φ14
18	10	27	38	6	TKG5-15-Φ18
22	15	33	41	6	TKG5-15-Φ22
28	20	39	44	6	TKG5-15-Φ28
34	25	49	46	8	TKG5-15-Φ34
42	32	57	50	8	TKG5-15-Φ42

TKG5-16 直通终端接头
TKG5-16 Extreme Straight-through Sleeve

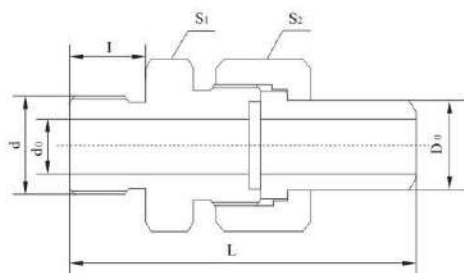

d	D ₀	d ₀	L	l	S ₁	S ₂	代号 Code
M10×1	6	3	45	9	14	17	TKG5-16-M10×1-Φ6
M10×1	10	4	51	9	17	19	TKG5-16-M10×1-Φ10
M14×1.5	10	6	55	12	19	19	TKG5-16-M14×1.5-Φ10
M14×1.5	14	8	61	12	24	27	TKG5-16-M14×1.5-Φ14
M18×1.5	14	10	63	14	27	27	TKG5-16-M18×1.5-Φ14
M18×1.5	18	10	69	14	30	32	TKG5-16-M18×1.5-Φ18
M22×1.5	18	12	69	14	32	32	TKG5-16-M22×1.5-Φ18
M22×1.5	22	12	70	14	32	36	TKG5-16-M22×1.5-Φ22
M27×1.5	22	15	74	16	36	36	TKG5-16-M27×2-Φ22
M27×1.5	28	17	79	16	41	41	TKG5-16-M27×2-Φ28
M33×2	28	20	79	16	41	41	TKG5-16-M33×2-Φ28
M33×2	34	22	86	16	46	50	TKG5-16-M33×2-Φ34
M42×2	34	25	92	18	55	50	TKG5-16-M42×2-Φ34
M42×2	42	28	96	18	55	60	TKG5-16-M42×2-Φ42
M48×2	42	32	98	20	60	60	TKG5-16-M48×2-Φ42
M48×2	50	40	106	20	65	70	TKG5-16-M48×2-Φ50
M10×1	6	3	77	41	14	17	TKG5-16J-M10×1-Φ6
M10×1	10	4	86	44	17	19	TKG5-16J-M10×1-Φ10
M14×1.5	10	6	90	47	19	19	TKG5-16J-M14×1.5-Φ10
M14×1.5	14	8	104	55	24	27	TKG5-16J-M14×1.5-Φ14
M18×1.5	14	10	106	57	27	27	TKG5-16J-M18×1.5-Φ14
M18×1.5	18	10	114	59	30	32	TKG5-16J-M18×1.5-Φ18
M22×1.5	18	12	114	59	32	32	TKG5-16J-M22×1.5-Φ18
M22×1.5	22	12	118	60	32	36	TKG5-16J-M22×1.5-Φ22
M27×2	22	15	122	64	36	36	TKG5-16J-M27×2-Φ22
M27×2	28	17	133	70	41	41	TKG5-16J-M27×2-Φ28
M33×2	28	20	133	70	41	41	TKG5-16J-M33×2-Φ28
M33×2	34	22	151	81	46	50	TKG5-16J-M33×2-Φ34
M42×2	34	25	157	83	55	50	TKG5-16J-M42×2-Φ34
M42×2	42	28	168	90	55	60	TKG5-16J-M42×2-Φ42
M48×2	42	32	172	92	60	60	TKG5-16J-M48×2-Φ42
M48×2	50	40	184	98	65	70	TKG5-16J-M48×2-Φ50

TKG5-17 直通终端锥管接头
TKG5-17 Extreme Straight-through Sleeve for Conical Pipe

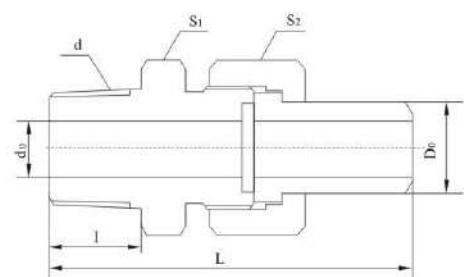

d	D ₀	d ₀	L	l	S ₁	S ₂	代号 Code
ZG1/8"	10	6	52	9	19	19	TKG5-17-ZG1/8"-Φ10
ZG1/4"	14	8	60	11	24	27	TKG5-17-ZG1/4"-Φ14
ZG3/8"	18	10	67	12	30	32	TKG5-17-ZG3/8"-Φ18
ZG1/2"	22	15	73	15	36	36	TKG5-17-ZG1/2"-Φ22
ZG3/4"	28	20	80	17	41	41	TKG5-17-ZG3/4"-Φ28
ZG1"	34	25	93	19	50	50	TKG5-17-ZG1"-Φ34
ZG1 1/4"	42	32	100	22	60	60	TKG5-17-ZG1 1/4"-Φ42
ZG1 1/2"	50	40	109	23	65	70	TKG5-17-ZG1 1/2"-Φ50
ZG1/8"	10	6	68	25	19	19	TKG5-17J-ZG1/8"-Φ10
ZG1/4"	14	8	83	29	24	27	TKG5-17J-ZG1/4"-Φ14
ZG3/8"	18	10	88	33	30	32	TKG5-17J-ZG3/8"-Φ18
ZG1/2"	22	15	93	35	36	36	TKG5-17J-ZG1/2"-Φ22
ZG3/4"	28	20	102	39	41	41	TKG5-17J-ZG3/4"-Φ28
ZG1"	34	25	120	48	50	50	TKG5-17J-ZG1"-Φ34
ZG1 1/4"	42	32	130	52	60	60	TKG5-17J-ZG1 1/4"-Φ42
ZG1 1/2"	50	40	142	56	65	70	TKG5-17J-ZG1 1/2"-Φ50

TKG5-18 直通中间接头
TKG5-18 Straight-through Intermediate Sleeve

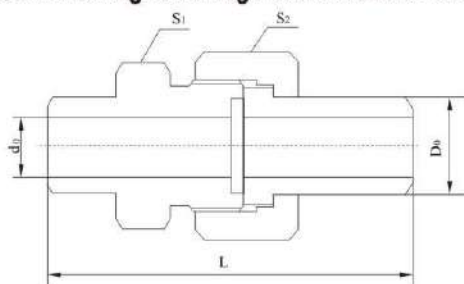

D ₀	d ₀	L	S ₁	S ₂	代号 Code
6	3	44	14	17	TKG5-18-Φ6
10	6	49	19	19	TKG5-18-Φ10
14	8	60	24	27	TKG5-18-Φ14
18	10	66	32	32	TKG5-18-Φ18
22	15	69	36	36	TKG5-18-Φ22
28	20	77	41	41	TKG5-18-Φ28
34	25	88	50	50	TKG5-18-Φ34
42	32	97	60	60	TKG5-18-Φ42
50	40	106	70	70	TKG5-18-Φ50

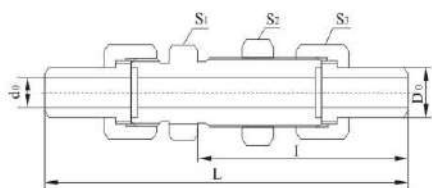
TKG5-19 直通穿板接头 TKG5-19 Straight-through Through Board Connector

D ₀	d ₀	L	I	S ₁	S ₂	S ₃	代号 Code
6	3	92	55	17	17	17	TKG5-19-φ6
10	6	104	61	19	22	19	TKG5-19-φ10
14	8	117	68	27	30	27	TKG5-19-φ14
18	10	127	72	32	36	32	TKG5-19-φ18
22	15	134	76	36	41	36	TKG5-19-φ22
28	20	144	81	41	50	41	TKG5-19-φ28
34	25	160	88	50	55	50	TKG5-19-φ34
42	32	174	96	60	65	60	TKG5-19-φ42
50	40	190	104	70	75	70	TKG5-19-φ50

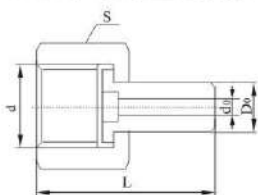
TKG5-20 压力表直通接头 TKG5-20 Manometer Straight-through Sleeve

d	D ₀	d ₀	L	S	代号 Code
M14×1.5	6	3	28	17	TKG5-20-M14×1.5-φ6
M20×1.5	14	8	38	27	TKG5-20-M20×1.5-φ14
G 1/2"	14	8	38	27	TKG5-20-G 1/2"-φ14

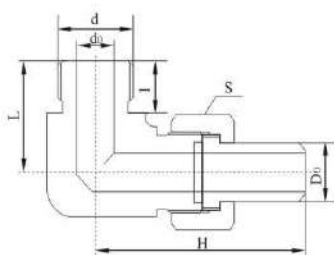
TKG5-21 弯通终端接头 TKG5-21 Extreme Elbow Pipe Connector

d	D ₀	d ₀	L	I	H	S	代号 Code
M10×1	10	6	20	9	46	19	TKG5-21-M10×1-φ10
M14×1.5	14	8	23	12	55	27	TKG5-21-M14×1.5-φ14
M18×1.5	18	10	30	14	63	32	TKG5-21-M18×1.5-φ18
M22×1.5	22	15	35	14	66	36	TKG5-21-M22×1.5-φ22
M27×2	28	20	37	16	86	41	TKG5-21-M27×2-φ28
M33×2	34	25	40	16	76	50	TKG5-21-M33×2-φ34
M42×2	42	32	47	18	95	60	TKG5-21-M42×2-φ42
M48×2	50	40	54	20	107	70	TKG5-21-M48×2-φ50

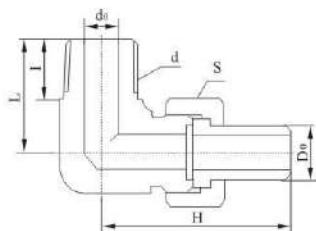
TKG5-22 弯通终端锥管接头 TKG5-22 Extreme Elbow Pipe Connector for Conn Conical Pipe

d	D ₀	d ₀	L	I	H	S	代号 Code
ZG1/8"	10	6	20	9	47	19	TKG5-22-ZG1/8"-φ10
ZG1/4"	14	8	22	11	55	27	TKG5-22-ZG1/4"-φ14
ZG3/8"	18	10	28	12	63	32	TKG5-22-ZG3/8"-φ18
ZG1/2"	22	15	36	15	68	36	TKG5-22-ZG1/2"-φ22
ZG1/4"	28	20	38	17	76	41	TKG5-22-ZG1/4"-φ28
ZG1"	34	25	43	19	88	50	TKG5-22-ZG1"-φ34
ZG1 1/4"	42	32	51	22	98	60	TKG5-22-ZG1 1/4"-φ42
ZG1 1/2"	50	40	57	23	107	70	TKG5-22-ZG1 1/2"-φ50

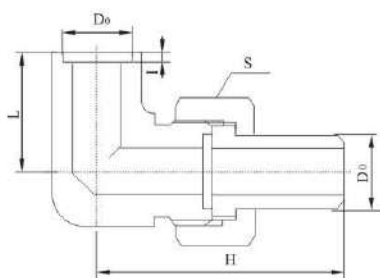
TKG5-23 弯通中间接头 TKG5-23 Elbow Pipe Intermediate Connector

D	D ₀	L	I	S	H	代号 Code
6	6	17	2	17	39	TKG5-23-φ6
10	10	20	2	19	46	TKG5-23-φ10
14	14	25	2	27	55	TKG5-23-φ14
18	18	29	2	32	63	TKG5-23-φ18
22	22	32	2	36	66	TKG5-23-φ22
28	28	36	2	41	74	TKG5-23-φ28
34	34	41	2	50	84	TKG5-23-φ34
42	42	48	3	60	94	TKG5-23-φ42
50	50	55	3	70	105	TKG5-23-φ50

TKG5-24 弯通穿板接头 TKG5-24 Elbow Pipe Through Board Connector

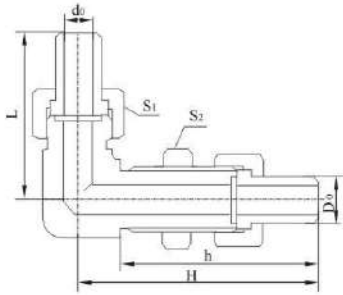

D	d	L	H	h	S ₁	S ₂	代号 Code
6	3	41	66	55	17	17	TKG5-24-Φ6
10	6	49	74	61	22	19	TKG5-24-Φ10
14	8	56	85	68	30	27	TKG5-24-Φ14
18	10	64	92	72	36	32	TKG5-24-Φ18
22	15	68	100	76	41	36	TKG5-24-Φ22
28	20	76	108	81	50	41	TKG5-24-Φ28
34	25	87	119	88	55	50	TKG5-24-Φ34
42	32	96	133	96	65	60	TKG5-24-Φ42
50	40	107	147	104	75	70	TKG5-24-Φ50

TKG5-25 三通中间接头 TKG5-25 T-pipe Intermediate Connector

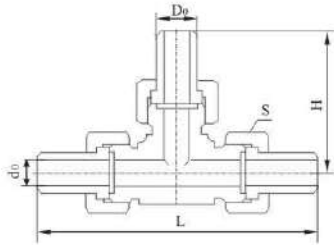

D ₀	d ₀	L	H	S	代号 Code
6	3	78	39	17	TKG5-25-Φ6
10	6	92	46	19	TKG5-25-Φ10
14	8	110	55	27	TKG5-25-Φ14
18	10	125	62	32	TKG5-25-Φ18
22	15	130	65	36	TKG5-25-Φ22
28	20	148	74	41	TKG5-25-Φ28
34	25	168	84	50	TKG5-25-Φ34
42	32	188	94	60	TKG5-25-Φ42
50	40	208	103	70	TKG5-25-Φ50

TKG5-26 四通中间接头 TKG5-26 Crossber Intermediate Connector

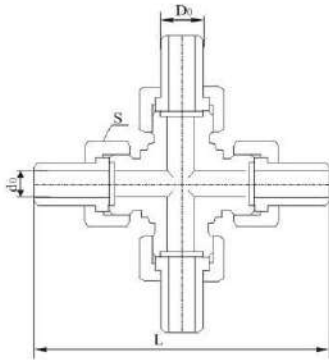

D ₀	d ₀	L	S	代号 Code
6	3	78	17	TKG5-26-Φ6
10	6	92	19	TKG5-26-Φ10
14	8	110	27	TKG5-26-Φ14
18	10	125	32	TKG5-26-Φ18
22	15	130	36	TKG5-26-Φ22
28	20	148	41	TKG5-26-Φ28
34	25	168	50	TKG5-26-Φ34
42	32	188	60	TKG5-26-Φ42
50	40	208	70	TKG5-26-Φ50

TKG5-27 铰接管接头 TKG5-27 Articulated Pipe Connector

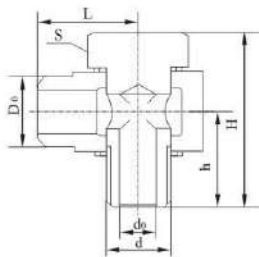

d	D ₀	d ₀	L	H	h	S	代号 Code
M10×1	10	4	16	32	17	17	TKG5-27-M10×1-Φ10
M14×1.5	14	8	22	40	22	19	TKG5-27-M14×1.5-Φ14
M18×1.5	18	11	27	47	26	24	TKG5-27-M18×1.5-Φ18
M20×1.5	18	12	27	47	26	27	TKG5-27-M20×1.5-Φ18
M22×1.5	22	14	33	58	32	30	TKG5-27-M22×1.5-Φ22
M24×1.5	22	16	33	58	32	32	TKG5-27-M24×1.5-Φ22
M27×2	28	18	38	67	36	36	TKG5-27-M27×2-Φ28

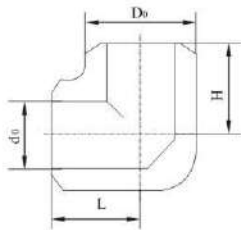
TKG5-28 弯通焊接接管
TKG5-28 Welding Connecting Pipe for Elbow Pipe

D ₀	d ₀	L	H	代号 Code
6	3	9	9	TKG5-28-Φ6
10	6	11	11	TKG5-28-Φ10
14	8	14	14	TKG5-28-Φ14
18	10	16	16	TKG5-28-Φ18
22	15	18	18	TKG5-28-Φ22
28	20	21	21	TKG5-28-Φ28
34	25	25	25	TKG5-28-Φ34
42	32	29	29	TKG5-28-Φ42
50	40	33	33	TKG5-28-Φ50

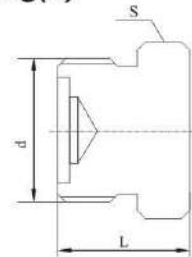
TKG5-29 堵头 (一)
TKG5-29 Plug(1)

d ₀	L	H	代号 Code
M12×1.25	16	14	TKG5-29-M12×1.25
M16×1.5	18	17	TKG5-29-M16×1.5
M22×1.5	21	24	TKG5-29-M22×1.5
M27×1.5	23	30	TKG5-29-M27×1.5
M30×1.5	24	32	TKG5-29-M30×1.5
M36×2	28	41	TKG5-29-M36×2
M42×2	32	46	TKG5-29-M42×2
M52×2	38	55	TKG5-29-M52×2
M60×2	42	65	TKG5-29-M60×2

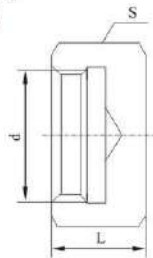
TKG5-30 堵头 (二)
TKG5-30 Plug(2)

d	L	S	代号 Code
M12×1.25	12	17	TKG5-30-M12×1.25
M16×1.5	14	19	TKG5-30-M16×1.5
M22×1.5	17	27	TKG5-30-M22×1.5
M27×1.5	20	32	TKG5-30-M27×1.5
M30×1.5	21	36	TKG5-30-M30×1.5
M36×2	22	41	TKG5-30-M36×2
M42×2	26	50	TKG5-30-M42×2
M52×2	28	60	TKG5-30-M52×2
M60×2	30	70	TKG5-30-M60×2

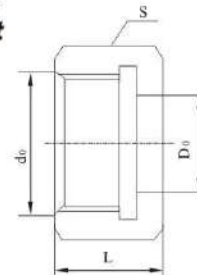
TKG5-31 螺母
TKG5-31 Nut

d	D ₀	L	S	代号 Code
M12×1.25	6	12	17	TKG5-31-M12×1.25
M16×1.5	10	14	19	TKG5-31-M16×1.5
M22×1.5	14	17	27	TKG5-31-M22×1.5
M27×1.5	18	20	32	TKG5-31-M27×1.5
M30×1.5	22	21	36	TKG5-31-M30×1.5
M36×2	28	22	41	TKG5-31-M36×2
M42×2	34	26	50	TKG5-31-M42×2
M52×2	42	28	60	TKG5-31-M52×2
M60×2	50	30	70	TKG5-31-M60×2

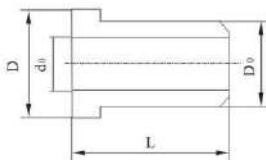
TKG5-32 接管
TKG5-32 Cometing Pipe

D ₀	d	D	L	代号 Code
6	3	10	20	TKG5-32-Φ6
10	6	14	24	TKG5-32-Φ10
14	8	20	28	TKG5-32-Φ14
18	10	24	32	TKG5-32-Φ18
22	15	27	32	TKG5-32-Φ22
28	20	33	35	TKG5-32-Φ28
34	25	39	38	TKG5-32-Φ34
42	32	49	40	TKG5-32-Φ42
50	40	27	44	TKG5-32-Φ50

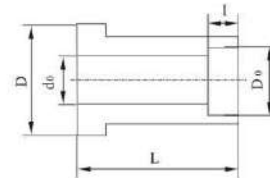
TKG5-33 变径接管
TKG5-33 Flexible Connecting Pipe

D ₀	d	D	L	I	代号 Code
6	3	24	20	5	TKG5-33-Φ6
10	6	28	24	5	TKG5-33-Φ10
14	8	32	28	5	TKG5-33-Φ14
18	10	32	32	6	TKG5-33-Φ18
22	15	35	32	6	TKG5-33-Φ22
28	20	38	35	6	TKG5-33-Φ28
34	25	40	38	8	TKG5-33-Φ34
42	32	44	40	8	TKG5-33-Φ42

TKG6-16 系列自控管路附件

TKG6-16 Gauge Pipe Auxliary

TKG6 承插焊式接头
TKG6 Spigot-and-socket pipe connector

• 材料: 20、1Cr18Ni9Ti、316、316L
• Material: 20、1Cr18Ni9Ti、316、316L

TKG6-1 承插焊异径接头 TKG6-1 Spigot-and-socket Socket Reducing

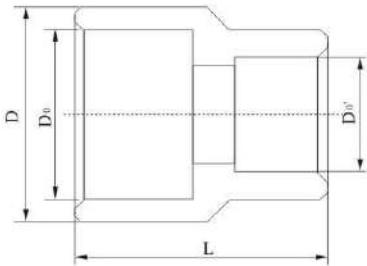

D ₀	D ₀ '	D	L	代号 Code No.
28	19	35	42	TKG6-1-Φ28-Φ19
35	19	44	45	TKG6-1-Φ35-Φ19
49	19	65	48	TKG6-1-Φ49-Φ19
28	23	35	44	TKG6-1-Φ28-Φ23
35	23	44	47	TKG6-1-Φ35-Φ25
49	23	65	50	TKG6-1-Φ49-Φ23
35	28	44	48	TKG6-1-Φ35-Φ28
49	28	65	52	TKG6-1-Φ49-Φ28

TKG6-2 承插焊弯通接头 TKG6-2 Spigot-and-socket Welding Elbow Pipe Connector

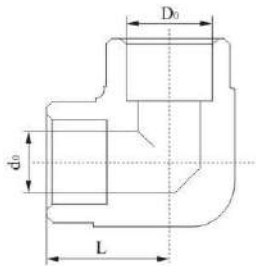

D ₀	d ₀	L	代号 Code No.
15	11	22	TKG6-2-Φ15
19	13	25	TKG6-2-Φ19
23	18	30	TKG6-2-Φ23
28	23	35	TKG6-2-Φ28
35	29	40	TKG6-2-Φ35
49	43	53	TKG6-2-Φ49

TKG6-3 承插焊三通接头 TKG6-3 Spigot-and-socket Welding T-pipe Connector

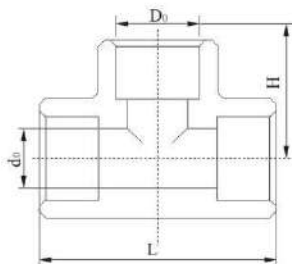

D ₀	d ₀	L	H	代号 Code No.
15	11	44	22	TKG6-3-Φ15
19	13	50	26	TKG6-3-Φ19
23	18	60	30	TKG6-3-Φ23
28	23	70	35	TKG6-3-Φ28
35	29	80	40	TKG6-3-Φ35
49	43	106	53	TKG6-3-Φ49

TKG6-4 承插焊四通接头 TKG6-4 Spigot-and-socket Welding Crossbar Connector

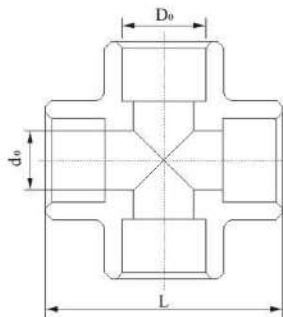

D ₀	d ₀	L	代号 Code No.
15	11	44	TKG6-4-Φ15
19	13	50	TKG6-4-Φ19
23	18	60	TKG6-4-Φ23
28	23	70	TKG6-4-Φ28
35	29	80	TKG6-4-Φ35
49	43	106	TKG6-4-Φ49

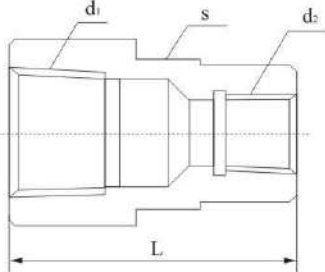
TKG7 内螺纹式管接头
TKG7-1 Female Pipe Adapter
TKG7-1 内螺纹异径接头
TKG7-1 Inside Thread Reducing Union

- 材料 material 20、304、1Cr18Ni9Ti、316、316L
- 螺纹可 thread can be M、G、ZG、PT、NPT

d1	d2	L	S	代号 Code
ZG 1/4"	ZG 1/4"	30	19	TKG7-1-ZG1/4"
ZG 3/8"	ZG 3/8"	35	19	TKG7-1-ZG3/8"
ZG 1/2"	ZG 1/2"	45	24	TKG7-1-ZG1/2"
ZG 3/4"	ZG 3/4"	50	30	TKG7-1-ZG3/4"
ZG1"	ZG1"	55	36	TKG7-1-ZG1"
ZG1 1/2"	ZG1 1/2"	65	50	TKG7-1-ZG1 1/2"
ZG2"	ZG2"	70	60	TKG7-1-ZG2"
ZG 1/2"	ZG 1/4"	45	24	TKG7-1-ZG1/2"-ZG 1/4"
ZG 3/4"	ZG 3/8"	50	30	TKG7-1-ZG3/4"-ZG 3/8"
ZG1"	ZG 3/8"	60	36	TKG7-1-ZG1"-ZG 3/8"
ZG1"	ZG 3/4"	60	36	TKG7-1-ZG1"-ZG 3/4"
ZG1 1/2"	ZG 3/4"	70	50	TKG7-1-ZG1 1/2"-ZG3/4"
ZG1 1/2"	ZG1"	70	50	TKG7-1-ZG1 1/2"-ZG1"
ZG2"	ZG1"	75	60	TKG7-1-ZG2"-ZG1"

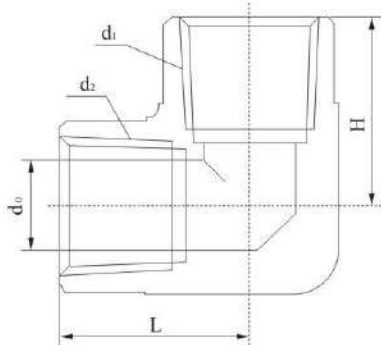
TKG7-2 内螺纹弯通接头
TKG7-2 Inside Thread Elbow Pipe Connector

d1	d2	d0	L	H	代号 Code
ZG 1/4"	ZG 1/4"	8	21	21	TKG7-2-ZG 1/4"
ZG 1/2"	ZG 1/2"	14	28	28	TKG7-2-ZG 1/2"
ZG 3/4"	ZG 3/4"	20	34	34	TKG7-2-ZG 3/4"
ZG1"	ZG1"	25	39	39	TKG7-2-ZG1"
ZG1 1/4"	ZG1 1/4"	32	45	45	TKG7-2-ZG1 1/4"
ZG1 1/2"	ZG1 1/2"	38	50	50	TKG7-2-ZG1 1/2"
ZG2"	ZG2"	48	59	59	TKG7-2-ZG2"
ZG 1/2"	ZG 1/4"	8	24	25	TKG7-2-ZG1/2" -ZG 1/4"
ZG 3/4"	ZG 1/4"	8	28	18	TKG7-2-ZG3/4" -ZG 1/4"
ZG1"	ZG 1/2"	14	33	33	TKG7-2-ZG1" -ZG 1/2"
ZG1 1/4"	ZG 1/2"	14	37	36	TKG7-2-ZG1 1/4" -ZG1/2"
ZG1 1/2"	ZG 1/2"	14	40	37	TKG7-2-ZG1 1/2" -ZG1 1/2"
ZG 3/4"	ZG 1/2"	14	32	31	TKG7-2-ZG3/4" -ZG1/2"
ZG 1/4"	ZG 1/4"	8	21	21	TKG7-2-ZG 1/4"
ZG 1/2"	ZG 1/2"	13	28	28	TKG7-2-ZG 1/2"
ZG 3/4"	ZG 3/4"	18	34	34	TKG7-2-ZG 3/4"
ZG1"	ZG1"	23	38	38	TKG7-2-ZG1"
ZG1 1/4"	ZG1 1/4"	30	44	44	TKG7-2-ZG1 1/4"
ZG1 1/2"	ZG1 1/2"	36	48	48	TKG7-2-ZG1 1/2"
ZG2"	ZG2"	45	57	57	TKG7-2-ZG2"
ZG 1/2"	ZG 1/4"	8	24	25	TKG7-2-ZG 1/2" -ZG 1/4"
ZG 3/4"	ZG 1/4"	8	27	29	TKG7-2-ZG 3/4" -ZG 1/4"
ZG1"	ZG 1/2"	13	33	33	TKG7-2-ZG1" -ZG 1/2"
ZG1 1/4"	ZG 1/2"	13	37	36	TKG7-2-ZG1 1/4" -ZG 1/2"
ZG1 1/2"	ZG 1/2"	13	39	37	TKG7-2-ZG1 1/2" -ZG 1/2"
ZG 3/4"	ZG 1/2"	13	30	31	TKG7-2-ZG 3/4" -ZG 1/2"

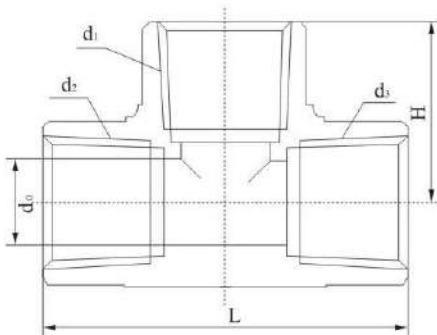
TKG7-3 内螺纹三通接头
TKG7-3 Inside Thread T-pipe Connector

d1	d2	d3	d0	L	H	代号 Code
ZG1/4"	ZG1/4"	ZG1/4"	8	43	21	TKG7-3-ZG1/4"
ZG1/2"	ZG1/2"	ZG1/2"	14	57	28	TKG7-3-ZG1/2"
ZG3/4"	ZG3/4"	ZG3/4"	20	68	34	TKG7-3-ZG3/4"
ZG1"	ZG1"	ZG1"	25	79	39	TKG7-3-ZG1"
ZG11/4"	ZG11/4"	ZG11/4"	32	90	45	TKG7-3-ZG11/4"
ZG11/2"	ZG11/2"	ZG11/2"	38	100	50	TKG7-3-ZG11/2"
ZG2"	ZG2"	ZG2"	48	118	59	TKG7-3-ZG2"
ZG1/2"	ZG 3/4"	ZG 3/4"	20	62	31	TKG7-3-ZG 1/2" -ZG 3/4" -ZG 3/4"
ZG3/4"	ZG 1/2"	ZG 1/2"	20	65	34	TKG7-3-ZG3/4"-ZG1/2"-ZG1/2"
ZG1/2"	ZG1"	ZG1"	25	68	33	TKG7-3-ZG1/2"-ZG1"-ZG1"
ZG1"	ZG1/2"	ZG1"	25	73	39	TKG7-3-ZG1"-ZG1/2"-ZG1"
ZG11/2"	ZG11/4"	ZG11/4"	32	72	37	TKG7-3-ZG1/2"-ZG11/4"-ZG11/4"
ZG11/4"	ZG1/2"	ZG11/4"	32	82	45	TKG7-3-ZG11/4"-ZG1/2"-ZG11/4"
ZG1/2"	ZG11/2"	ZG11/2"	38	76	40	TKG7-3-ZG1/2"-ZG11/2"-ZG11/2"
ZG11/4"	ZG1/2"	ZG11/2"	38	90	50	TKG7-3-ZG11/4"-ZG1/2"-ZG11/2"
ZG1/4"	ZG1/4"	ZG11/2"	8	42	21	TKG7-3-ZG1/4"-ZG1/4"-ZG11/2"
ZG1/2"	ZG1/2"	ZG1/4"	13	56	28	TKG7-3-ZG1/2"-ZG 1/2"-ZG1/4"
ZG3/4"	ZG3/4"	ZG1/2"	18	68	34	TKG7-3-ZG3/4"-ZG3/4"-ZG1/2"
ZG1"	ZG1"	ZG3/4"	23	76	38	TKG7-3-ZG1"-ZG1"-ZG3/4"
ZG1 1/4"	ZG11/4"	ZG1"	30	89	44	TKG7-3-ZG11/4"-ZG11/4"-ZG1"
ZG1 1/2"	ZG11/2"	ZG11/4"	36	97	48	TKG7-3-ZG11/2"-ZG11/2"-ZG11/4"
ZG2"	ZG2"	ZG11/2"	45	115	57	TKG7-3-ZG2"-ZG2"-ZG11/2"

TKG8 金属软管接头

TKG8 Metal Hose Connector

材料 material 20、1Cr18Ni9Ti、316、316L

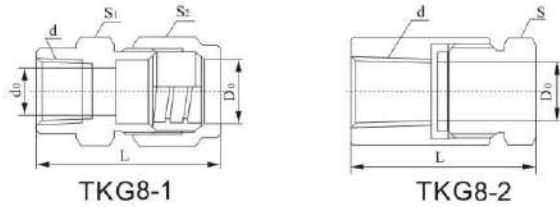

TKG8-1 内螺纹金属管接头 (一)

TKG8-1 Inside Thread Metal Hose Connector(1)

d	D ₀	d ₀	L	S ₁	S ₂	代号 Code No
ZG 1/2"	19.5	15	59	30	30	TKG8-1-ZG 1/2"-DN15
ZG 3/4"	19.5	15	62	32	30	TKG8-1-ZG 3/4"-DN15
ZG1"	19.5	15	65	36	30	TKG8-1-ZG1"-DN15
ZG 1/2"	25	17	75	36	36	TKG8-1-ZG 1/2"-DN20
ZG 3/4"	25	20	77	36	36	TKG8-1-ZG 3/4"-DN20
ZG1"	25	20	79	36	36	TKG8-1-ZG1"-DN20

TKG8-2 内螺纹金属管接头 (二)

TKG8-2 Inside Thread Metal Hose Connector(2)

d	D ₀	L	S	代号 Code No
ZG1/2"	13	53	27	TKG8-2-ZG1/2"-Φ13
ZG1/2"	17	53	27	TKG8-2-ZG1/2"-Φ17
ZG1/2"	21	53	27	TKG8-2-ZG1/2"-Φ21
ZG3/4"	21	57	27	TKG8-2-ZG3/4"-Φ21
ZG1"	31	76	41	TKG8-2-ZG1"-Φ31
ZG1 1/2"	46	84	58	TKG8-2-ZG1 1/2"-Φ46

TKG8-3 内螺纹金属管接头 (三)

TKG8-3 Inside Thread Metal Hose Connector(3)

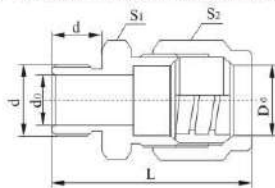

d	D ₀	d ₀	L	I	S ₁	S ₂	代号 Code No
M16×1.5	17	11	49	12	27	27	TKG8-3-M16×1.5-DN13
M18×1.5	19.5	13	56	14	30	30	TKG8-3-M18×1.5-DN15
M20×1.5	19.5	14	56	14	30	30	TKG8-3-M20×1.5-DN15
M27×2	25	20	64	16	36	36	TKG8-3-M27×2-DN20
M33×2	31	25	71	21	41	46	TKG8-3-M33×2-DN25
G 1/2"	19.5	14	56	14	30	30	TKG8-3-G 1/2"-DN15
G 3/4"	19.5	14	58	16	30	30	TKG8-3-G 3/4"-DN15
G1"	25	20	69	21	36	36	TKG8-3-G1"-DN20
ZG 1/2"	19.5	14	60	18	30	30	TKG8-3-ZG 1/2"-DN15
ZG 3/4"	19.5	14	62	20	30	30	TKG8-3-ZG 3/4"-DN15

TKG9 橡胶管接头

TKG9 Rubber hose connector

材料 Material 20、H62

TKG9-1 端焊接橡胶管接头

TKG9-1 Extreme Welding Rubber Hose Connector

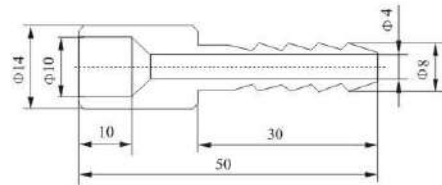

TKG9-2 端螺纹橡胶管接头 (一)

TKG9-2 Extreme Thread Rubber Hose Connector(1)

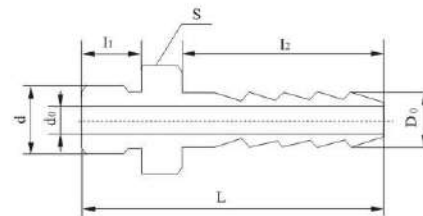

d	D ₀	d ₀	L	I ₁	I ₂	S	代号 Code No
M10×1	8	4	45	9	30	14	TKG9-2-M10×1
ZG1/2"	8	4	45	9	30	14	TKG9-2-ZG1/2"
ZG1/4"	10	6	47	13	30	14	TKG9-2-ZG1/4"-1
ZG1/4"	8	4	51	13	30	14	TKG9-2-ZG1/4"-2
ZG3/8"	8	4	52	14	30	19	TKG9-2-ZG3/8"
G1/2"	18	8	100	20	50	27	TKG9-2-G1/2"
ZG1/2"	8	4	57.5	17.5	30	24	TKG9-2-ZG1/2"
G3/4"	24	14	100	20	50	30	TKG9-2-G3/4"
ZG3/4"	8	4	61.5	19.5	30	32	TKG9-2-ZG3/4"
G1"	30	18	100	20	50	41	TKG9-2-G1"

TKG9-3 端螺纹橡胶管接头 (二)

TKG9-3 Extreme Thread Rubber Hose Connector(2)

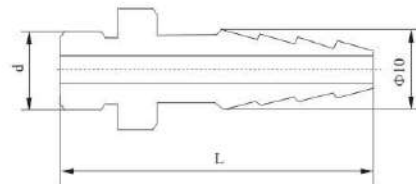

d	L	代号 Code No
M10×1	54	TKG9-3-M10×1
ZG 1/4"	58	TKG9-3-ZG 1/4"
ZG 1/2"	64.5	TKG9-3-G 1/2"
ZG 3/4"	64.5	TKG9-3-G 3/4"

TKG10 电缆 (管缆) 接头
TKG10 Cable(pipe Cable) Connector

- 材料: 20、1Cr18Ni9Ti、316、316L
- Material: 20、1Cr18Ni9Ti、316、316L

TKG10-1 填料函
TKG10-1 Stuffing Box

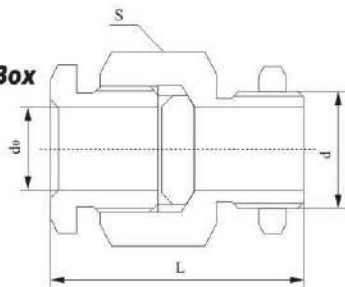

d	d ₀	S	L	代号 Code No
M22×1.5	16	32	47	TKG10-1-Φ16
M27×1.5	20	36	47	TKG10-1-Φ20
M30×1.5	24	41	66	TKG10-1-Φ24
M36×2	30	55	66	TKG10-1-Φ30
M42×2	36	55	66	TKG10-1-Φ36

TKG10-2 填料函
TKG10-2 Stuffing Case

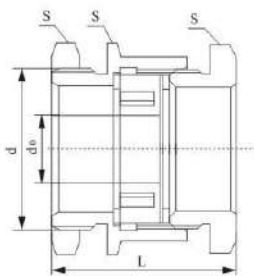

d	d ₀	S	L	代号 Code No
M22×1	7.5	24	28.5	TKG10-2-M22×1
M48×2	20	55	54	TKG10-2-M48×2

TKG10-3 电缆管接头 (一)
TKG10-3 Cable Pipe Connector (1)

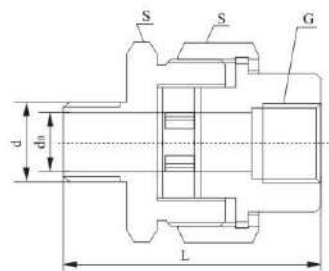

d	G	d ₀	L	S	代号 Code No
G 3/4"	G 3/4"	10	42	58	TKG10-3-Φ10
G1"	G1"	16	50	67	TKG10-3-Φ16

TKG10-4 电缆管接头 (二)
TKG10-4 Cable Pipe Connector (2)

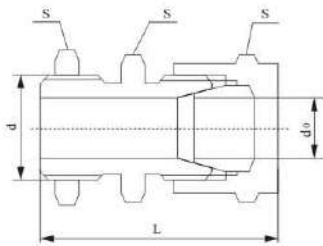

d	d ₀	S	S _i	L	代号 Code No
M12×1.5	5	14	17	28	TKG10-4-M12×1.5-Φ5
M14×1.5	7	17	19	32	TKG10-4-M14×1.5-Φ7
M16×1.5	9	19	22	32	TKG10-4-M16×1.5-Φ9
M18×1.5	9	22	24	34	TKG10-4-M18×1.5-Φ9
M20×1.5	11	24	27	34	TKG10-4-M20×1.5-Φ11
M24×1.5	13	27	30	40	TKG10-4-M24×1.5-Φ13
M27×2	15	30	32	40	TKG10-4-M27×2-Φ15
M30×2	18	32	36	47	TKG10-4-M30×2-Φ18
M33×2	21	36	41	47	TKG10-4-M33×2-Φ21
M36×2	24	41	46	50	TKG10-4-M36×2-Φ24
M42×2	28	46	50	50	TKG10-4-M42×2-Φ28
M48×2	32	55	60	56	TKG10-4-M48×2-Φ32
M60×2	36	65	70	56	TKG10-4-M60×2-Φ36
M64×2	40	70	75	56	TKG10-4-M64×2-Φ40

TKG10-5 (屏蔽) 电缆管接头 (三)
TKG10-5 (Shielded) Cable Pipe Connector (3)

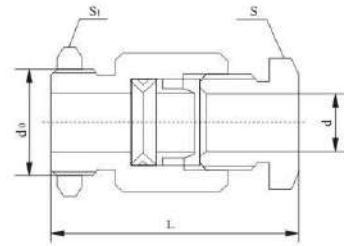

d	d ₀	S	S _i	L	代号 Code No
M16×1.5	8	19	22	43	TKG10-5-M16×1.5-Φ8
M18×1.5	10	22	24	43	TKG10-5-M18×1.5-Φ10
M20×1.5	11	24	27	43	TKG10-5-M20×1.5-Φ11
M24×1.5	14	27	30	48	TKG10-5-M24×1.5-Φ14
M27×2	17	30	32	48	TKG10-5-M27×2-Φ17
M30×2	20	32	36	54	TKG10-5-M30×2-Φ20
M33×2	23	36	41	54	TKG10-5-M33×2-Φ23
M36×2	26	41	46	59	TKG10-5-M36×2-Φ26
M42×2	30	46	50	59	TKG10-5-M42×2-Φ30
M45×2	32	50	55	65	TKG10-5-M45×2-Φ32
M48×2	34	55	60	65	TKG10-5-M48×2-Φ34
M56×2	36	60	65	74	TKG10-5-M56×2-Φ36
M60×2	38	65	70	74	TKG10-5-M60×2-Φ38
M60×2	42	65	70	74	TKG10-5-M60×2-Φ42

TKG11连接头 (管嘴)

TKG11 Connector (nouthpiece)

- 材料: 20、1Cr18Ni9Ti、316、316L
- Material: 20、1Cr18Ni9Ti、316、316L

TKG11-1 直形连接头 (一)

TKG11-1 Straight Connector (1)

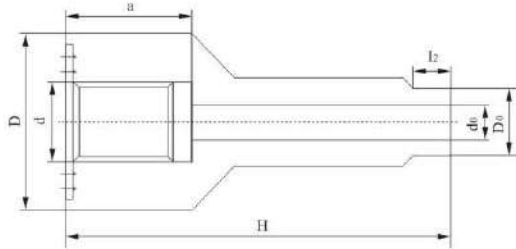

d	D ₀	d ₀	D	H	a	l ₂	代号 Code No
M16×1.5	14	7	36	80	27	8	TKG11-1-M16×1.5
M20×1.5	14	7	40	80	27	8	TKG11-1-M20×1.5
M27×2	22	18	47	60	32	8	TKG11-1-M27×2-1
M27×2	22	18	47	80	32	8	TKG11-1-M27×2-2
M27×2	22	18	47	120	32	8	TKG11-1-M27×2-3
M27×2	22	18	47	140	32	8	TKG11-1-M27×2-4
M33×2	30	24	55	60	34	8	TKG11-1-M33×2-1
M33×2	30	24	55	80	34	8	TKG11-1-M33×2-2
M33×2	30	24	55	120	34	8	TKG11-1-M33×2-3
M33×2	30	24	55	140	34	8	TKG11-1-M33×2-4
G1/2"	21	16	39	60	35	8	TKG11-1-G1/2"-1
G1/2"	21	16	39	80	35	8	TKG11-1-G1/2"-2
G1/2"	21	16	39	120	35	8	TKG11-1-G1/2"-3
G3/4"	25	20	47	60	41	8	TKG11-1-G3/4"-1
G3/4"	25	20	47	70	41	8	TKG11-1-G3/4"-2
G3/4"	25	20	47	80	41	8	TKG11-1-G3/4"-3
G3/4"	25	20	47	120	41	8	TKG11-1-G3/4"-4
G1"	35	25	55	60	42	8	TKG11-1-G1"-1
G1"	35	25	55	70	42	8	TKG11-1-G1"-2
G1"	35	25	55	80	42	8	TKG11-1-G1"-3
G1"	35	25	55	120	42	8	TKG11-1-G1"-4
G1 1/2"	40	30	70	80	45	8	TKG11-1-G1 1/2"-1
G1 1/2"	40	30	70	120	45	8	TKG11-1-G1 1/2"-2

TKG11-2 直形连接头 (二)

TKG11-2 Straight Connector (2)

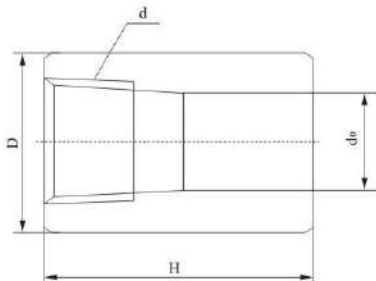

d	d ₀	D	H	代号 Code No
ZG1 1/2"	18	30	40	TKG11-2-ZG1 1/2"-1
ZG1 1/2"	18	30	60	TKG11-2-ZG1 1/2"-2
ZG1 1/2"	18	30	120	TKG11-2-ZG1 1/2"-3
ZG3/4"	23	35	45	TKG11-2-ZG3/4"-1
ZG3/4"	23	35	80	TKG11-2-ZG3/4"-2
ZG3/4"	23	35	120	TKG11-2-ZG3/4"-3
ZG1"	29	44	50	TKG11-2-ZG1"-1
ZG1"	29	44	80	TKG11-2-ZG1"-2
ZG1"	29	44	120	TKG11-2-ZG1"-3
ZG1 1/2"	43	65	70	TKG11-2-ZG1 1/2"-1
ZG1 1/2"	43	65	100	TKG11-2-ZG1 1/2"-2
ZG1 1/2"	43	65	120	TKG11-2-ZG1 1/2"-3

TKG11-3 45° 角形连接头

TKG11-3 45° Angle Connector

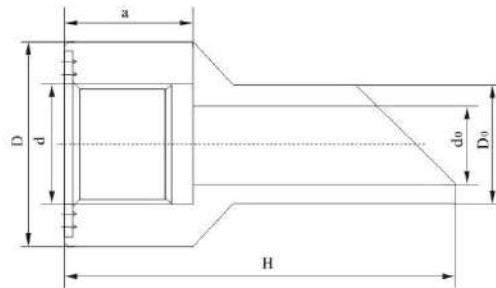

d	D ₀	d ₀	D	H	s	代号 Code No
M27×2	28	18	47	90	30	TKG11-3-M27×2-1
M27×2	28	18	47	110	30	TKG11-3-M27×2-2
M27×2	28	18	47	140	30	TKG11-3-M27×2-3
M27×2	28	18	47	150	30	TKG11-3-M27×2-4
M33×2	36	24	55	90	30	TKG11-3-M33×2-1
M33×2	36	24	55	110	30	TKG11-3-M33×2-2
M33×2	36	24	55	140	30	TKG11-3-M33×2-3
M33×2	36	24	55	150	30	TKG11-3-M33×2-4
G1/2"	27	16	39	90	30	TKG11-3-G1/2"-1
G1/2"	27	16	39	140	30	TKG11-3-G1/2"-2
G1/2"	27	16	39	150	30	TKG11-3-G1/2"-3
G3/4"	31	20	47	90	30	TKG11-3-G3/4"-1
G3/4"	31	20	47	140	30	TKG11-3-G3/4"-2
G3/4"	31	20	47	150	30	TKG11-3-G3/4"-3
ZG1"	41	25	55	90	40	TKG11-3-G1"-1
ZG1"	41	25	55	110	40	TKG11-3-G1"-2
ZG1"	41	25	55	150	40	TKG11-3-G1"-3
ZG1 1/2"	58	44	70	150	25	TKG11-3-G1 1/2"

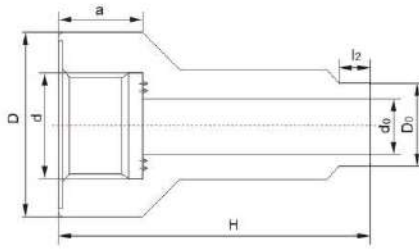
TKG11-4 双金属温度计直形管嘴
TKG11-4 Double-metal Thermometer Straight Mouthpiece

d	D ₀	d ₀	D	H	a	l ₂	代 号 Code No
M27×2	22	14	47	80	22	8	TKG11-4-1
M27×2	22	14	47	100	22	8	TKG11-4-2
M27×2	22	14	47	140	22	8	TKG11-4-3

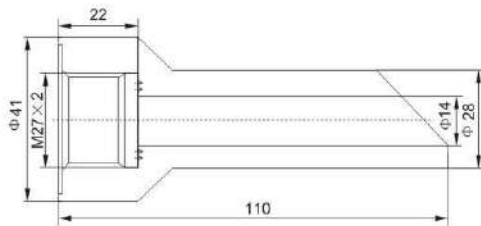
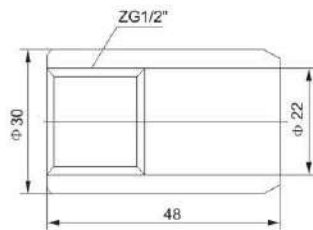
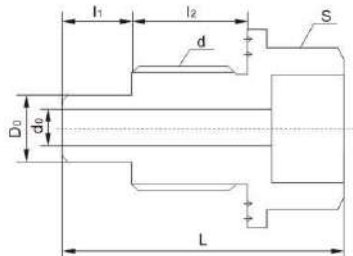
TKG11-5 双金属温度计斜形管嘴
TKG11-5 Double-metal Thermometer Oblique Mouthpiece

TKG11-6 表面热电偶连接头
TKG11-6 Surface Thermoelement Connector

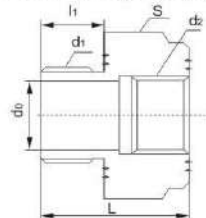
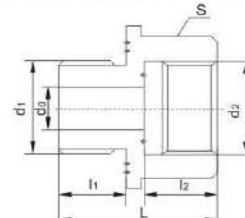
TKG11-7 温度计套管
TKG11-7 Thermometer Bush

d	D ₀	d ₀	L	l ₁	l ₂	S	代 号 Code No
G 3/4"	14	8	79	35	24	30	TKG11-7-G 3/4"-Φ 14-79
G 3/4"	14	8	99	55	24	30	TKG11-7-G 3/4"-Φ 14-99
G 3/4"	14	8	119	75	24	30	TKG11-7-G 3/4"-Φ 14-119
G 3/4"	14	8	139	95	24	30	TKG11-7-G 3/4"-Φ 14-139
G 3/4"	14	8	179	135	24	30	TKG11-7-G 3/4"-Φ 14-179
G 3/4"	14	8	219	175	24	30	TKG11-7-G 3/4"-Φ 14-219
G 3/4"	14	8	269	225	24	30	TKG11-7-G 3/4"-Φ 14-269
G 3/4"	14	8	339	295	24	30	TKG11-7-G 3/4"-Φ 14-339
G 3/4"	14	8	419	375	24	30	TKG11-7-G 3/4"-Φ 14-419
G 3/4"	14	8	519	475	24	30	TKG11-7-G 3/4"-Φ 14-519
G1"	22	16	172	120	29	36	TKG11-7-G1"-Φ 22-172
G1"	22	16	222	170	29	36	TKG11-7-G1"-Φ 22-222
G1"	22	16	322	270	29	36	TKG11-7-G1"-Φ 22-322
G1"	22	16	422	370	29	36	TKG11-7-G1"-Φ 22-422
G1"	22	16	522	470	29	36	TKG11-7-G1"-Φ 22-522
G1"	22	16	772	720	29	36	TKG11-7-G1"-Φ 22-772
G1"	22	16	1022	970	29	36	TKG11-7-G1"-Φ 22-1022
G1"	22	16	1272	1220	29	36	TKG11-7-G1"-Φ 22-1272
G1"	22	16	2022	1970	29	36	TKG11-7-G1"-Φ 22-2022
G1"	22	16	2522	2170	29	36	TKG11-7-G1"-Φ 22-2522

TKG11-8 温度计转换接头 (一)
TKG11-8 Thermometer Adapter(1)

TKG11-9 温度计转换接头 (二)
TKG11-9 Thermometer Adapter(2)

D ₁	d ₂	d ₀	L	l ₁	S	代 号 Code No
G1"	G 3/4"	Φ24	47	20	50	TKG11-8-G1"
M27×2	G 3/4"	Φ18	47	20	50	TKG11-8-M27×2

d ₁	d ₂	d ₀	L	l ₁	l ₂	S	代 号 Code No
G 3/4"	M27×2	Φ12	43	18	20	36	TKG11-9-G 3/4"
G1"	M27×2	Φ12	45	20	20	36	TKG11-9-G1"

TKG12 压力表接头
TKG12 Manometer Connector

材料: 20、1Cr18Ni9Ti、316、316L
Material: 20、1Cr18Ni9Ti、316、316L

TKG12-1 接表阀接头 TKG12-1 Valve Connector to Meter

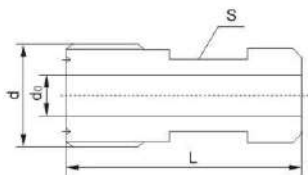

d	d ₀	L	S	代号 Code No
M20×1.5左	8	45	14	TKG12-1

TKG12-2 压力表组合接头 TKG12-2 Manometer Combined Connector

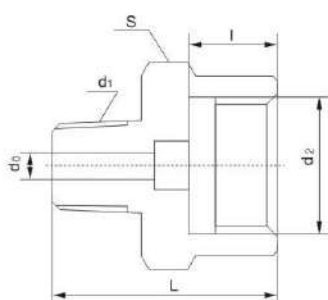

d	d ₂	d	L	I	S	代号 Code No
ZG 1/8"	M10×1	4	26	10	14	TKG12-2-ZG 1/8" -M10×1
ZG 1/8"	M12×1.25	4	27	12	17	TKG12-2-ZG 1/8" -M12×1.25
ZG 1/8"	M14×1.5	4	31	13	19	TKG12-2-ZG 1/8" -M14×1.5
ZG 1/8"	M20×1.5	4	32	13	27	TKG12-2-ZG 1/8" -M20×1.5
ZG 1/8"	G 1/2"	4	32	13	27	TKG12-2-ZG 1/8" -G 1/2"
ZG 1/4"	M10×1	4	29	10	17	TKG12-2-ZG 1/4" -M10×1
ZG 1/4"	M12×1.25	4	29	12	17	TKG12-2-ZG 1/4" -M12×1.25
ZG 1/4"	M14×1.5	4	32	13	19	TKG12-2-ZG 1/4" -M14×1.5
ZG 1/4"	M20×1.5	4	33	13	27	TKG12-2-ZG 1/4" -M20×1.5
ZG 1/4"	G 1/2"	4	33	13	27	TKG12-2-ZG 1/4" -G 1/2"

TKG12-3 压力表接头 (A) TKG12-3 Manometer Connector(A)

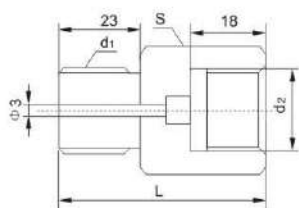

d ₁	d ₂	L	S	代号 Code No
G 1/2"	M20×1.5	53	27	TKG12-3

TKG12-4 压力表接头(B) TKG12-4 Manometer Connector(B)

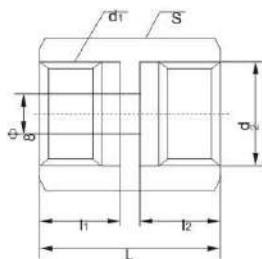

d ₁	d ₂	l ₁	l ₂	L	S	代号 Code No
G 1/4"	G 1/2"	13	16	33	27	TKG12-4-ZG 1/4" -G 1/2"
G 1/2"	M10×1	16	16	36	27	TKG12-4-ZG 1/2" -M20×1.5

TKG12-5 压力表接头 (C) TKG12-5 Manometer Connector(C)

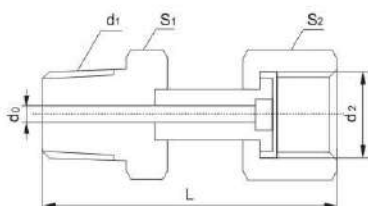

d ₁	d ₂	d ₀	l ₁	S1	S2	代号 Code No
ZG 1/4"	M20×1.5	4	65	19	27	TKG12-5-ZG 1/4"
ZG 1/2"	M20×1.5	4	70	27	27	TKG12-5-ZG 1/2"

TKG13 玻璃板液面计接头
TKG13 Plate Liquid Level Indicator Connector

材料 Material: 20、1Cr18Ni9Ti、316、316L

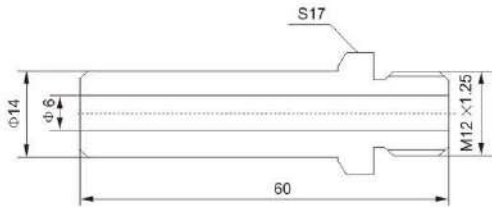
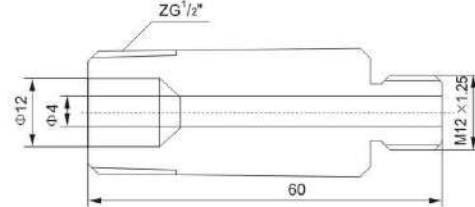
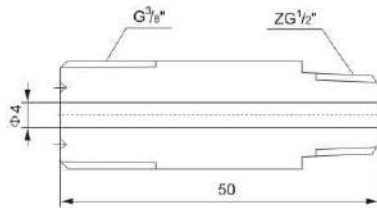
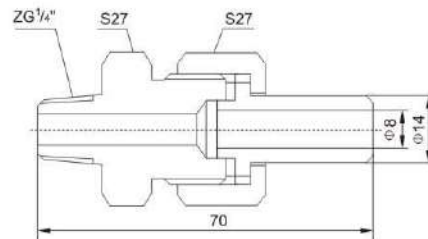
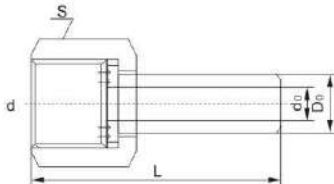
TKG13-1 液面计排污接头 (一)
TKG13-1 Liquid Level Indicator Drainage Connector(1)

TKG13-2 液面计排污接头 (二)
TKG13-2 Liquid Level Indicator Drainage Connector(2)

TKG13-3 液面计蒸汽夹套接头 (一)
TKG13-3 Liquid Level Indicator Steam Collet Connector(1)

TKG13-4 液面计蒸汽夹套接头 (二)
TKG13-4 Liquid Level Indicator Steam Collet Connector(2)

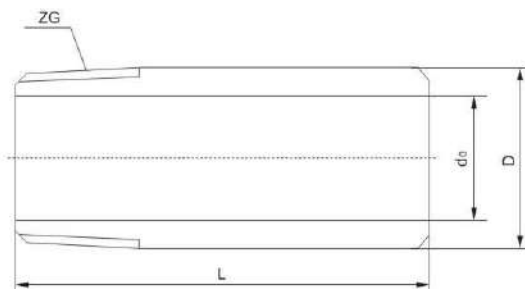
TKG13-5 液面计蒸汽夹套接头 (三)
TKG13-5 Liquid Level Indicator Steam Collet Connector(3)

D	d	d_0	L	S	代号 Code No
8	G 3/8"	4	50	24	TKG13-5-1
10	G 3/8"	6	42	24	TKG13-5-2
8	G 1/2"	4	63	30	TKG13-5-3

TKG14 短节 TKG14 Brachypiece

材料 Material: 20、1Cr18Ni9Ti、316、316L

TKG14-1 单头短节·单头加厚短节
TKG14-1 Single head brachypiece. Thick single head bead brachypiece

ZG	D	d_0	L	代号 Code No
ZG 1/4"	14	8	50	TKG14-1-ZG 1/4"
ZG 3/8"	18	10	70	TKG14-1-ZG 3/8"
ZG 1/2"	22	15	70	TKG14-1-ZG 1/2"
ZG 3/4"	27	20	70	TKG14-1-ZG 3/4"
ZG1"	34	27	100	TKG14-1-ZG1"
ZG1 1/2"	48	31	100	TKG14-1-ZG1 1/2"
ZG2"	60	45	120	TKG14-1-ZG2"
ZG 1/4"	14	3	50	TKG14-1-ZG 1/4" -J
ZG 3/8"	18	5	70	TKG14-1-ZG 3/8" -J
ZG 1/2"	22	10	70	TKG14-1-ZG 1/2" -J
ZG 3/4"	27	15	70	TKG14-1-ZG 3/4" -J
ZG1"	34	22	100	TKG14-1-ZG1" -J
ZG1 1/2"	48	28	100	TKG14-1-ZG1 1/2" -J
ZG2"	60	40	120	TKG14-1-ZG2" -J

TKG14-2 双头短节, 双头加厚短节

TKG14-2 Double Head Brachypiece Thick Double Head

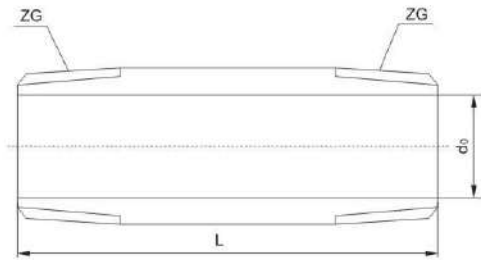

ZG	d ₀	L	代号 Code No
ZG1/4"	8	60	TKG14-2-ZG1/4"
ZG3/8"	10	60	TKG14-2-ZG3/8"
ZG1/2"	15	60	TKG14-2-ZG1/2"
ZG3/4"	20	70	TKG14-2-ZG3/4"
ZG1"	27	80	TKG14-2-ZG1"
ZG1 1/2"	31	120	TKG14-2-ZG1 1/2"
ZG2"	45	120	TKG14-2-ZG2"
ZG1/4"	3	60	TKG14-2-ZG1/4"-J
ZG3/8"	5	60	TKG14-2-ZG3/8"-J
ZG1/2"	10	60	TKG14-2-ZG1/2"-J
ZG3/4"	15	70	TKG14-2-ZG3/4"-J
ZG1"	22	80	TKG14-2-ZG1"-J
ZG1 1/2"	28	120	TKG14-2-ZG1 1/2"-J
ZG2"	40	120	TKG14-2-ZG2"-J

代号中注“J”者为加厚短节 The code with onte “J” indicates the Strengthened Short Connector

TKG14-3 单头异径短节

TKG14-3 Single Head Special Brachypiece

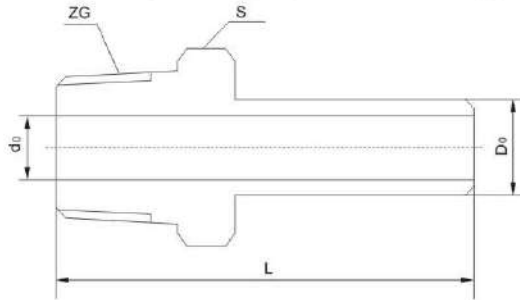

ZG	D ₀	d ₀	S	L	代号 Code No
ZG 3/8"	14	9	19	120	TKG14-3-ZG 3/8" -Φ14
ZG 1/2"	14	9	24	120	TKG14-3-ZG 1/2" -Φ14
ZG 3/4"	14	9	30	120	TKG14-3-ZG 3/4" -Φ14

TKG14-4 异径短节

TKG14-4 Special Brachypiece

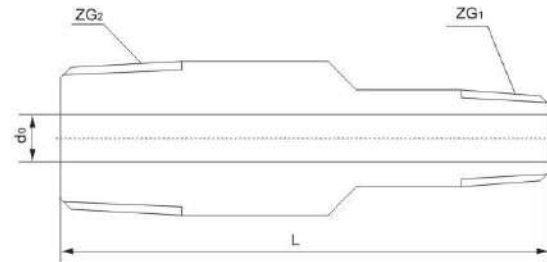

ZG ₁	ZG ₂	d ₀	L	代号 Code No
ZG1/4"	ZG1/2"	7	70	TKG14-4-ZG 1/4"-ZG1/2"
ZG1/4"	ZG3/4"	7	75	TKG14-4-ZG 1/4"-ZG3/4"
ZG1/2"	ZG3/4"	12	80	TKG14-4-ZG 1/2"-ZG3/4"
ZG3/4"	ZG1"	17	85	TKG14-4-ZG 3/4"-ZG1"
ZG1"	ZG1 1/2"	24	90	TKG14-4-ZG1"-ZG1 1/2"

TKG14-5 内外接头 (一)

TKG14-5 Inside-outside Connector(1)

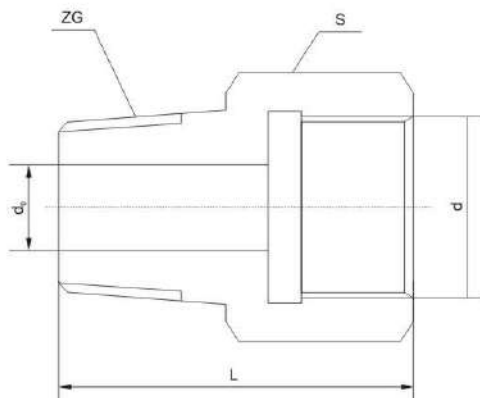

d	ZG	d ₀	S	L	代号 Code No
M10×1	ZG1/8"	4	17	26	TKG14-5-M10 ×1-ZG1/8"
M14×1.5	ZG1/8"	4	19	32	TKG14-5-M14 ×1.5-ZG1/8"
M10×1	ZG1/4"	6	19	30	TKG14-5-M10 ×1-ZG1/4"
M14×1.5	ZG1/4"	6	22	36	TKG14-5-M14 ×1.5-ZG1/4"
M18×1.5	ZG1/4"	6	24	36	TKG14-5-M18 ×1.5-ZG1/4"
M14×1.5	ZG3/8"	8	22	36	TKG14-5-M14 ×1.5-ZG3/8"
M18×1.5	ZG3/8"	8	24	36	TKG14-5-M18 ×1.5-ZG3/8"
M20×1.5	ZG3/8"	8	27	36	TKG14-5-M20 ×1.5-ZG3/8"
M18×1.5	ZG1/2"	10	27	42	TKG14-5-M18 ×1.5-ZG1/2"
M20×1.5	ZG1/2"	10	27	42	TKG14-5-M20 ×1.5-ZG1/2"
M22×1.5	ZG1/2"	10	30	44	TKG14-5-M22 ×1.5-ZG1/2"
M24×1.5	ZG1/2"	10	32	44	TKG14-5-M24 ×1.5-ZG1/2"
M24×1.5	ZG3/4"	15	32	44	TKG14-5-M24 ×1.5-ZG3/4"
M27×2	ZG3/4"	15	36	48	TKG14-5-M27 ×2-ZG3/4"
M33×2	ZG3/4"	15	41	52	TKG14-5-M33 ×2-ZG3/4"
M27×2	ZG1"	20	41	52	TKG14-5-M27 ×2-ZG1"
M33×2	ZG1"	20	46	56	TKG14-5-M33 ×2-ZG1"
M42×2	ZG1"	20	55	58	TKG14-5-M42 ×2-ZG1"
M33×2	ZG1/4"	25	50	56	TKG14-5-M33 ×2-ZG1/4"
M42×2	ZG1/4"	25	55	58	TKG14-5-M42 ×2-ZG1/4"
M48×2	ZG1/4"	25	60	60	TKG14-5-M48 ×2-ZG1/4"
M42×2	ZG1/2"	32	55	62	TKG14-5-M42 ×2-ZG1/2"
M48×2	ZG1/2"	32	60	62	TKG14-5-M48 ×2-ZG1/2"

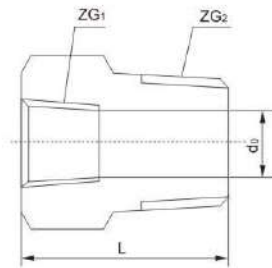
TKG14-6内外接头 (二) TKG14-6 Inside-outside Connector (2)

ZG ₁	ZG ₂	d ₀	L	代号 Code No
ZG 1/4"	ZG 1/2"	11	33.5	TKG14-6-ZG 1/4" -ZG 1/2"
ZG 1/2"	ZG 3/4"	18	37.5	TKG14-6-ZG 1/2" -ZG 3/4"
ZG 1/2"	ZG 1"	18	40	TKG14-6-ZG 1/2" -ZG 1"
ZG 1/2"	ZG1 1/2"	18	44	TKG14-6-ZG 1/2" -ZG1 1/2"
ZG 3/4"	ZG1 1/2"	23	48	TKG14-6-ZG 3/4" -ZG1 1/2"

TKG15 活接头
TKG15 Union

材料 Material: 20、1Cr18Ni9Ti、316、316L

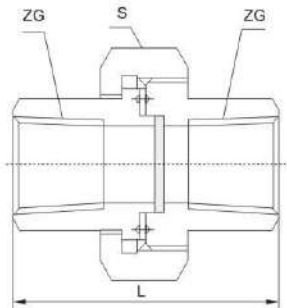
TKG15-1 内螺纹式活接头 TKG15-1 Inside Thread Union

ZG	S	L	代号 Code No
ZG 1/4"	36	48	TKG15-1-ZG 1/4"
ZG 3/8"	42	56	TKG15-1-ZG 3/8"
ZG 1/2"	46	60	TKG15-1-ZG 1/2"
ZG 3/4"	55	68	TKG15-1-ZG 3/4"
ZG1"	65	75	TKG15-1-ZG1"
ZG1 1/2"	75	84	TKG15-1-ZG1 1/2"
ZG2"	85	90	TKG15-1-ZG2"

公称压力: PN4MPa

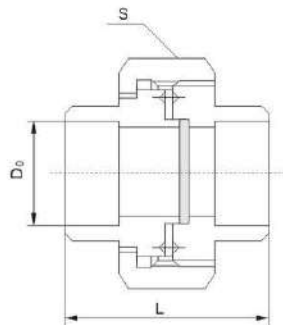
TKG15-2 焊接式活接头 (一) TKG15-2 Welding Union (1)

D ₀	S	L	代号 Code No
15	36	44	TKG15-2-Φ15
19	42	47	TKG15-2-Φ19
23	46	48	TKG15-2-Φ23
28	55	56	TKG15-2-Φ28
35	65	59	TKG15-2-Φ35
49	75	69	TKG15-2-Φ49
69	85	78	TKG15-2-Φ69

公称压力: PN4MPa

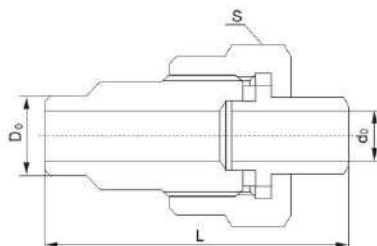
TKG15-3 焊接式活接头 (二) TKG15-3 Welding Union (2)

D ₀	d ₀	S	L	代号 Code No
20	13	41	78	TKG15-3-Φ20
24	16	46	88	TKG15-3-Φ24

公称压力: PN16MPa

TKG15-4 高压活接头 TKG15-4 High Pressure Union

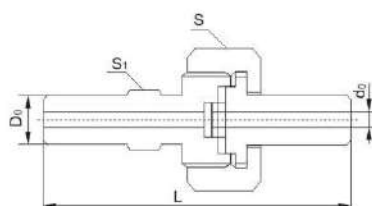

D ₀	d ₀	S	S ₁	L	代号 Code No
14	6	36	17	86	TKG15-4-Φ14
24	10	46	27	100	TKG15-4-Φ24
35	15	65	38	130	TKG15-4-Φ35

公称压力: PN32MPa

TKG15-5 异形活接头 TKG15-5 Special Use Union

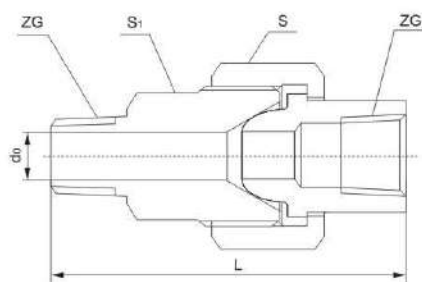

ZG	d ₀	S	S ₁	L	代号 Code No
ZG 1/4"	8	27	19	60	TKG15-5-ZG 1/4"
ZG 3/8"	10	32	22	66	TKG15-5-ZG 3/8"
ZG 1/2"	15	36	24	71	TKG15-5-ZG 1/2"
ZG 3/4"	20	46	32	67	TKG15-5-ZG 3/4"
ZG1"	25	60	41	80	TKG15-5-ZG1"
ZG 1 1/2"	40	75	55	88	TKG15-5-ZG 1 1/2"
ZG2"	50	90	65	96	TKG15-5-ZG2"

公称压力: PN10MPa

TKG16 堵头

TKG16 Plug

材料 Material: 20、1Cr18Ni9Ti、316、316L

TKG16-1 堵头 (一)

TKG16-1 Plug(1)

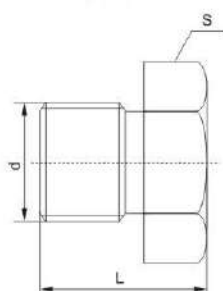

TKG16-2 堵头 (二)

TKG16-2 Plug(2)

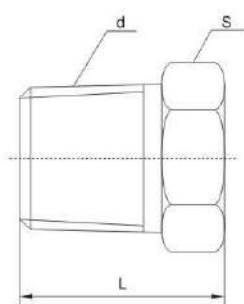

TKG16-3 内螺纹堵头

TKG16-3 (Insidel thread plug)

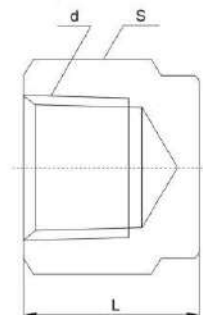

d	S	L	代号 Code No
G 1/4"	20	24	TKG16-1-G 1/4"
G 3/8"	23	27	TKG16-1-G 3/8"
G 1/2"	29	30	TKG16-1-G 2/2"
G 3/4"	34	36	TKG16-1-G 3/4"
M20×1.5	28	30	TKG16-1-M19×1.5
M27×2	34	36	TKG16-1-M27×2

d	L	S	代号 Code No
ZG 1/4"	22	17	TKG16-2-ZG 1/4"
ZG 3/8"	24	19	TKG16-2-ZG 3/8"
ZG 1/2"	29	24	TKG16-2-ZG 1/2"
ZG 3/4"	33	30	TKG16-2-ZG 3/4"
ZG1"	28	36	TKG16-2-ZG1"
ZG1 1/2"	45	55	TKG16-2-ZG1 1/2"

d	S	L	代号 Code No
ZG 1/4"	17	17	TKG16-3-ZG 1/4"
ZG 3/8"	20	22	TKG16-3-ZG 3/8"
ZG 1/2"	25	27	TKG16-3-ZG 1/2"
ZG 3/4"	30	32	TKG16-3-ZG 3/4"
ZG1"	36	41	TKG16-3-ZG1"
ZG1 1/2"	42	55	TKG16-3-ZG1 1/2"

TKG16-4 螺塞

TKG16-4 Plug Screw

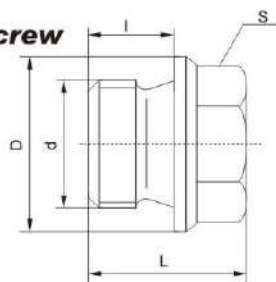

d	D	L	l	S	代号 Code No
M8×1	13	8	14	TKG16-4-M8×1	
M10×1	14	8	17	TKG16-4-M10×1	
M12×1.25	19	12	19	TKG16-4-M12×1.25	
M14×1.5	19	12	19	TKG16-4-M14×1.5	
M16×1.5	22	22	12	19	TKG16-4-M16×1.5
M18×1.5	25	22	12	19	TKG16-4-M18×1.5
M22×1.5	30	25	14	19	TKG16-4-M22×1.5
M27×2	35	29	16	22	TKG16-4-M27×2
M33×2	42	34	18	27	TKG16-4-M33×2
M42×2	53	41	20	36	TKG16-4-M42×2

TKF系列仪表辅助容器 TKF Gauge Auxiliary Container

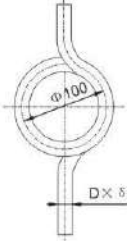
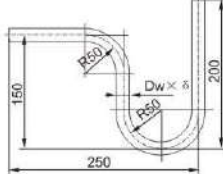
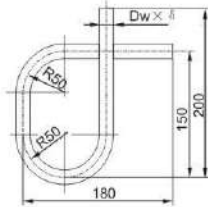
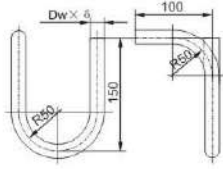
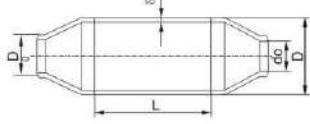
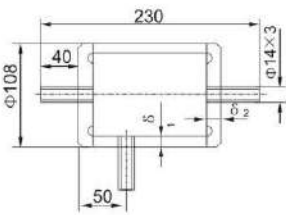
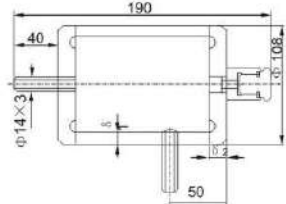
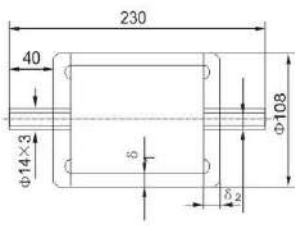
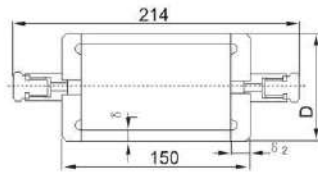
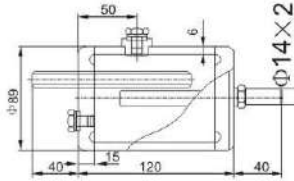
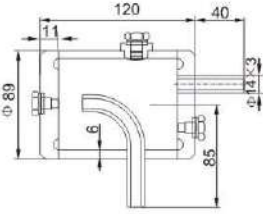
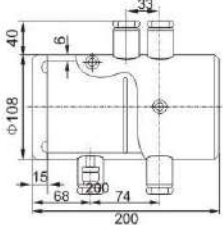
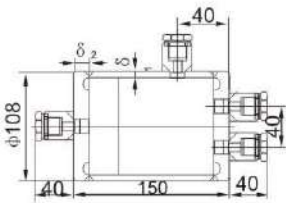
<p>TKF1-1 冷凝圈 (HK02-001) TKF1-1 Condensation ring</p>  <p>$D \times \delta$: $\Phi 14 \times 2$ $\Phi 18 \times 3$</p>	<p>TKF1-2 冷凝弯(一) TKF1-2 Condensation bend(1)</p>  <p>$D \times \delta$: $\Phi 14 \times 2$ $\Phi 18 \times 3$</p>	<p>TKF1-3 冷凝弯(二) TKF1-3 Condensation bend(2)</p>  <p>$D \times \delta$: $\Phi 14 \times 2$ $\Phi 18 \times 3$</p>	<p>TKF1-4 冷凝弯(三) TKF1-4 Condensation bend(3)</p>  <p>$D \times \delta$: $\Phi 14 \times 2$ $\Phi 18 \times 3$</p>																										
<p>TKF1-5 温度计扩大管 TKF1-5 Thermometer Enlarged Tude</p>  <table border="1" data-bbox="183 1019 598 1153"> <thead> <tr> <th>管道能径 do</th> <th>10</th> <th>15</th> <th>20</th> <th>25</th> <th>32</th> <th>40</th> <th>50</th> <th>70</th> </tr> </thead> <tbody> <tr> <td>大小头 长度 A</td> <td>$D \times \delta$ 57×3.5</td> <td>120</td> <td>100</td> <td>100</td> <td>75</td> <td>75</td> <td>75</td> <td></td> </tr> <tr> <td></td> <td>$D \times \delta$ 57×3.5</td> <td>120</td> <td>120</td> <td>100</td> <td>100</td> <td>100</td> <td>75</td> <td>75</td> </tr> </tbody> </table>	管道能径 do	10	15	20	25	32	40	50	70	大小头 长度 A	$D \times \delta$ 57×3.5	120	100	100	75	75	75			$D \times \delta$ 57×3.5	120	120	100	100	100	75	75	<p>TKF1-6 冷凝容器(一) TKF1-6 Condensation vessel(1)</p>  <p>公称压力: Nominal Pressure PN6.4 PN16</p>	<p>TKF1-7 冷凝容器(二) TKF1-7 Condensation vessel(2)</p>  <p>公称压力: Nominal Pressure PN6.4 PN16</p>
管道能径 do	10	15	20	25	32	40	50	70																					
大小头 长度 A	$D \times \delta$ 57×3.5	120	100	100	75	75	75																						
	$D \times \delta$ 57×3.5	120	120	100	100	100	75	75																					
<p>TKF1-8 分离容器 TKF1-8 Separation vessel</p>  <p>公称压力: PN6.4 PN16 Nominal Pressure</p>	<p>TKF1-9 分离容器(一) TKF1-9 Isolation vessel(1)</p>  <p>公称压力: PN6.4 Nominal Pressure</p>	<p>TKF1-10 FG1-64 型隔离容器 (二) TKF1-10 FG1-64 Isolation vessel</p>  <p>公称压力: PN6.4 Nominal Pressure</p>																											
<p>TKF1-11 FG2-64 型隔离容器(三) TKF1-11 FG2-64 Isolation vessel</p>  <p>公称压力: PN6.4 Nominal Pressure</p>	<p>TKF1-12 FG3-64 型隔离容器(四) TKF1-12 FG3-64 Isolation vessel</p>  <p>公称压力: PN6.4 Nominal Pressure</p>	<p>TKF1-13 FG1-4A 型隔离容器(五) TKF1-13 FG1-4A Isolation vessel</p>  <p>公称压力: PN6.4 PN16 Nominal Pressure</p>																											

TKF1-14 FG4B 型隔离容器(六)
TKF1-14 FG4B Isolation vessel

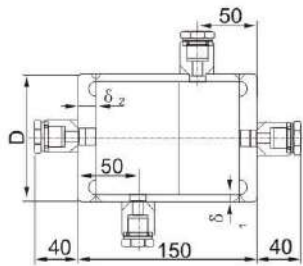

公称压力:PN6.4 PN16
Nominal Pressure

TKF1-15 双室平衡容器
TKF1-15 Two chamber balance vessel

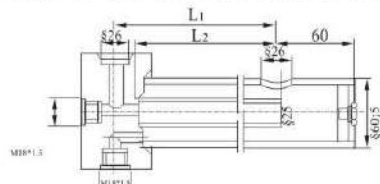

公称压力:PN6.4
Nominal Pressure

序号	量程范围	L1	L2
1	±300	600	581
2	±320	640	621
3	±500	1000	981

TKF1-16 沉降除尘器
TKF1-16 Subside dust-remover

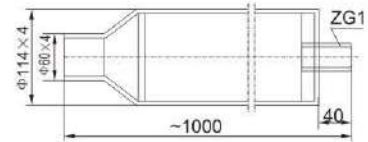

公称压力:PN1.0
Nominal Pressure

TKF1-17 旋风除尘器
TKF1-17 Whirl wind dust-remover

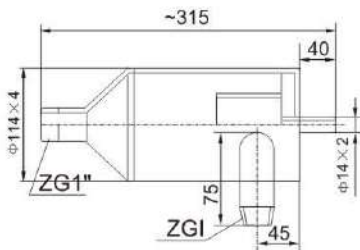

公称压力:PN1.0
Nominal Pressure

TKF1-18 虹吸管圈
TKF1-18 Siphon pipe ring

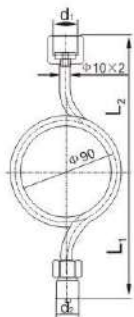

序号	d ₁	d ₂
1	G3/8"	G3/8"
2	G1/2"	G1/2"
3	G3/8"	ZG3/8"
4	G1/2"	ZG1/2"

公称压力:PN20
Nominal Pressure

TKF1-19 虹吸管圈
TKF1-19 Iphon vessel

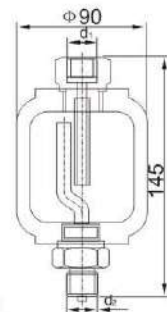

公称压力:PN15
Nominal Pressure

TKF1-20 压力表虹吸器
TKF1-20 Siphon Container for manometer

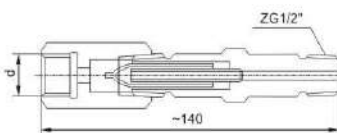

公称压力:Pa2.5mpa
Nominal Pressure

TKF1-21 冷凝器(L1-2.5 型)
TKF1-21 Condenser

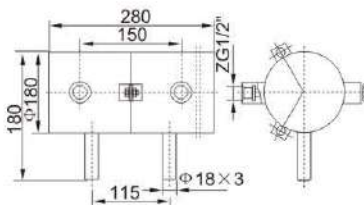

公称压力:Pa2.5mpa
Nominal Pressure

TKF1-22 隔离器(GL型)
TKF1-22 Isolation vessel

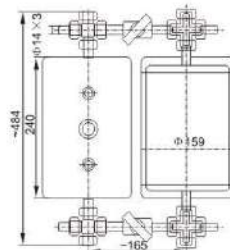

公称压力:PN6.4
Nominal Pressure

TKF1-23 集气器(JQ 型)
TKF1-23 Collect gas vessel

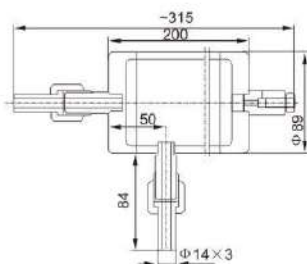

公称压力:PN1.0 PN6.4
Nominal Pressure

TKF1-24 沉降器(CJI 型气用)
TKF1-24 Subside(use for gas)

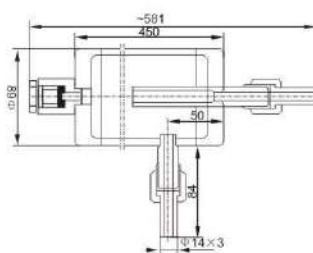

公称压力:PN6.4 PN1.0
Nominal Pressure

TKF1-25 沉降器(CJ II型液用)
TKF1-25 Subside(use for liquid)

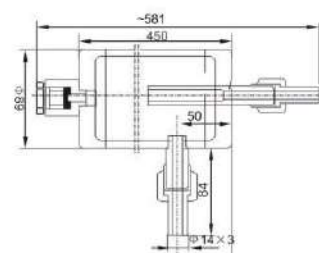

公称压力:PN6.4 PN1.0
Nominal Pressure

TKKFQ系列气源分配器 **TKKFQ Gas distributor**

TKKFQ 系列气源分配器是集中安装的气动仪表与仪表空气总管相连的中间桥梁，其一端用外螺纹接头或法兰方式与供气箱连接，终端用气源球阀或堵头，定期将空气中的冷凝水从分配器中排出，以免水源进入气动仪表内。

TKKFQ series air distributor is the bridge of pneumatic instrument and air main pipe of the instrument. One end is connected with the air supply box a external thread joint or flange method and the terminal adopts the air ball valve or end. It regularly draws out the condensate steam in the air from the distributor. Thus to prevent the water from entering into the pneumatic instrument

型号编制说明 **Compilation of the type**

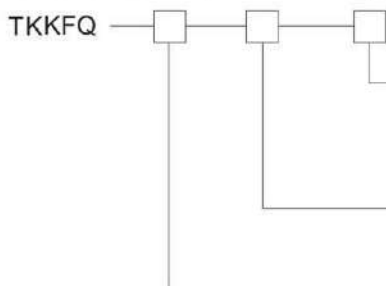

配管用材料 T: 配紫铜管或尼龙管 S: 配塑料管

The material of the accessorized type T: Accessorize red copper pipe or nylon pipe. S: Accessorize plastic pipe.

供气点数 6, 12, 24。

Air-supply tally: 6, 12, 24

结构形式代号 I: 螺纹连接(本体材料 20# 或 1Cr18Ni9Ti)

Structure formal code: I: thread connection (bulk material 20# or 1Cr18Ni9Ti)

II: 法兰连接(本体材料为 20# 或 1Cr18Ni9Ti)

II: flange connection (bulk material 20# or 1Cr18Ni9Ti)

III: 螺纹连接(本体材料 H62 或 1Cr18Ni9Ti 的方棒)

III: thread connection (bulk material H62 or 1Cr18Ni9Ti square rod)

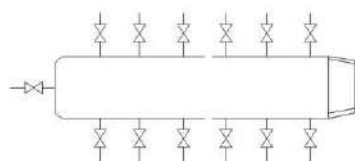

TKKFQ-I 型

序号 NO.	型号 Type	公称压力 MPa	供气点数	配管外径	连接方式
1	TKKFQ-I-6	<1	6	Φ6 或 Φ8	螺纹 ZG3/4"
2	TKKFQ-I-12		12		
3	TKKFQ-I-24		24		

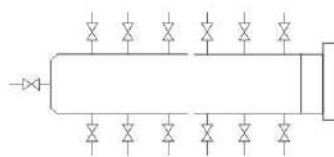

TKKFQ-II 型

序号 NO.	型号 Type	公称压力 MPa	供气点数	配管外径	连接方式
1	TKKFQ-II-6	<1	6	Φ6 或 Φ8	法兰连接
2	TKKFQ-II-12		12		
3	TKKFQ-II-24		24		

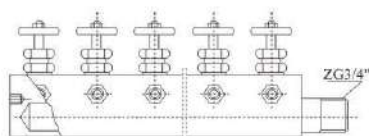

TKKFQ-III 型

序号 NO.	型号 Type	公称压力 MPa	供气点数	配管外径	连接方式
1	TKKFQ-III-12	<1	6	Φ6 或 Φ8	螺纹 ZG3/4"
2	TKKFQ-III-12		12		
3	TKKFQ-III-12		24		

防堵风压取样装置 *Anti-wind pressure sampling device*

PFD系列防堵风压取样器

PFD系列防堵风压取样器是本厂根据气体对流原理和物质的比重大小研制出来的最为理想的取样装置。测量含粉尘的气体通过取样筒下端，经过三层特殊要求的防堵机构，层层对流再回落，层层进行分离含固粉尘，由于粉尘的比重大于气体，粉尘下落到取样筒锥端直至取样容器，净化后的气体可以被风压测量装置获得正确的测量信号，以达到防堵风压取样的目的。该装置不但可以测量一个点的静压，也可以测量二个点的差压。该装置内部结构均为不锈钢，外部有碳钢与不锈钢之分。

PFD series anti-wind pressure sampling device

PFD series anti-wind pressure sampling device is an ideal sampling device developed by our company in according with gas convection theory and material proportion. When measuring the gas with dust, firstly gas drops into the bottom of sampling tube, then passes through anti-blocking with three special requirements. Solid dust will be separated after through three convection layers. Because dust is heavier than gas, dust drops into container of sampling tube. Purified gas can be correctly measured by wind pressure measuring device to achieve the purpose of anti-wind pressure sampling. The device not only can measure static pressure of one point, but also can measure different pressure of two points. The inner structure material of the device is stainless steel. But the outer structure material of the device is composed of carbon steel and stainless steel.

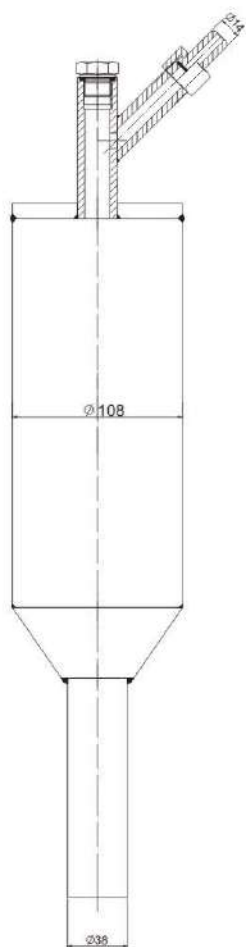

TKPFD-1

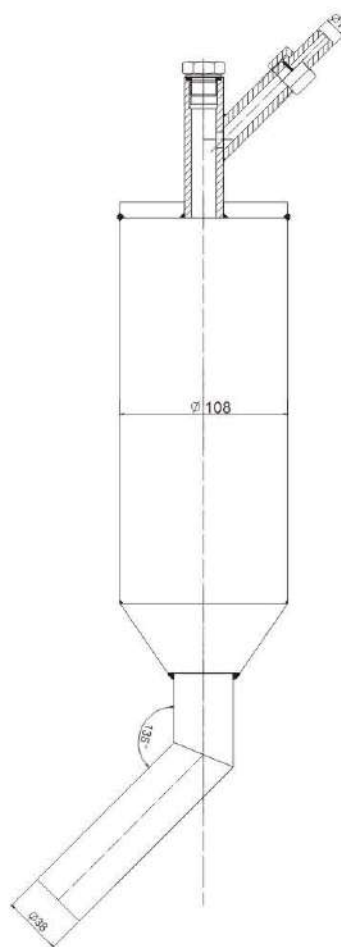

TKPFD-2

TKYX^W_H 系列仪表保温保护箱

TKYX^W_H 系列仪表保护箱及保温箱是变送器及其它仪表现场安装保护或保温设备，它具有标准化、程度高、造型美观，结构合理、形式多样、安装操作方便等特点。保护箱由箱体、仪表托架等部件组成，保温箱结构形式与保护箱相同，所不同的是箱内装有电器加热或蒸汽加热装置。

TKYX^W_H series instrument protection box and incubation are used in transmitter and other protection and thermal insulation equipment which need on-site installation. They have such features as high standard, beautiful shaping, reasonable structure, various types and they are convenient for installation. The protection box is mainly made of casing and instrument cradle. The structure of incubator is the same as the protection box's, the difference is electric heating system or the steam heating system which is installed in the box.

一、仪表保护（保温）箱型谱编制说明

The compilation of the type of instrument protection box/incubator:

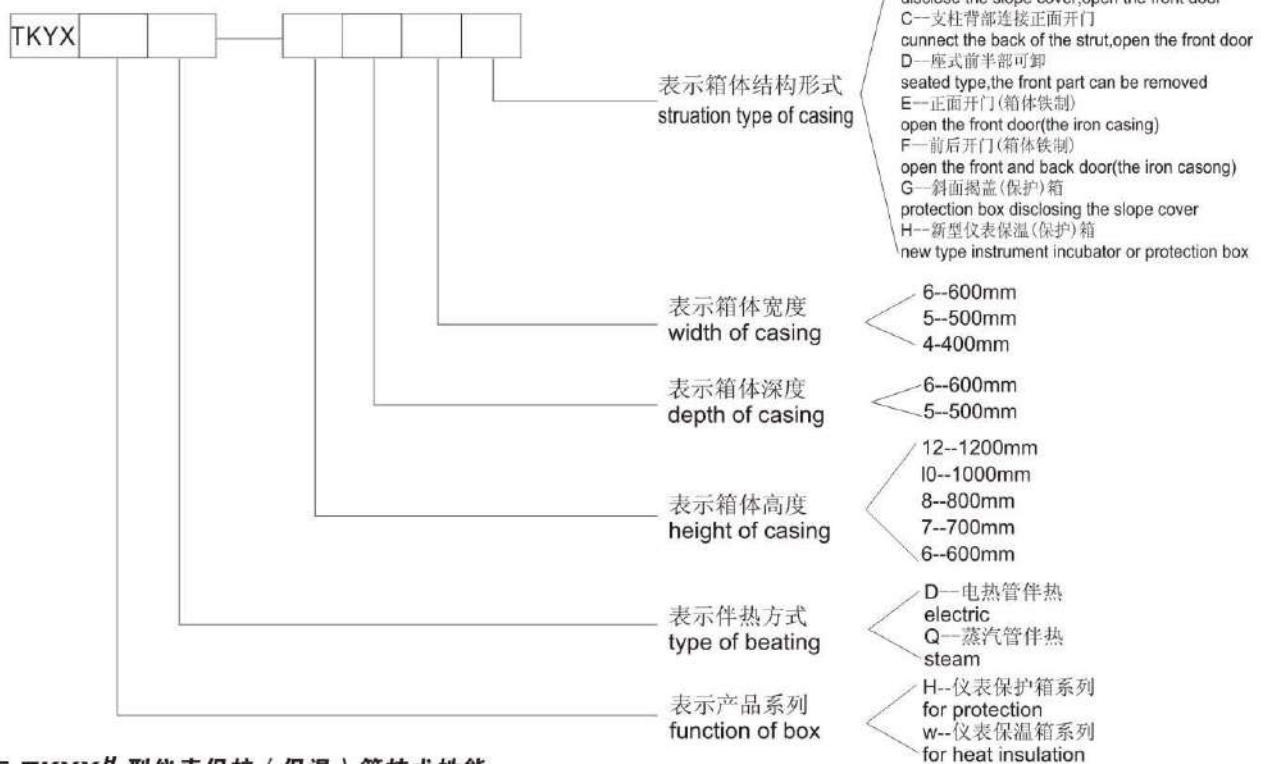

二、TKYX^H_W 型仪表保护（保温）箱技术性能

TKYX^H_W type instrument protection box/incubator's technical property

1、聚酯树脂玻璃钢的机械性能见表

The mechanical property of polyester and resin organic toughened glass, please see the list.

拉伸强度 T.S MPa	弯曲强度 F.S Mpa	冲击强度 P.S Mpa	压缩强度 C.S Mpa	自然老化年数 natural aging years	比重S.G kg/m ³
209.0	320.2	16.9	230.0	8~10	1600

2、保温性能: 10~25℃

3、环境温度: -50~60℃

4、饱和蒸汽压力: 0.5MPa

5、伴热蒸汽消耗量: 0.35~0.8kg/h.

6、额定电压: 220V.

Heating range: 10~25℃

Ambient temperature: -50~60℃

Pressure of saturated steam: 0.5MPa

Steam consumption: 0.35—0.8kg/h.

Rated voltage: 220V

三、TKYX_{WH}型仪表保温箱伴热结构说明

TKYX_{WH} type instrument incubator's accompanying heating structure

I、电热管伴热:

TKYX_{WH}电加热保温箱由箱体、加热器、仪表托架等三大部分组成。其结构形式与保护箱相同，所不同的是箱内装有电器加热装置，其结构形式如图，电热装置是由电热管，温度控制器组成，箱体侧面装有插座，当接通电源后，箱内加热到所需温度时，由温度控制器切断电源；当温度下降到一定温度时，再由温度控制器接通电源继续升温。通过反复工作使箱内温度能保持在一定范围内。

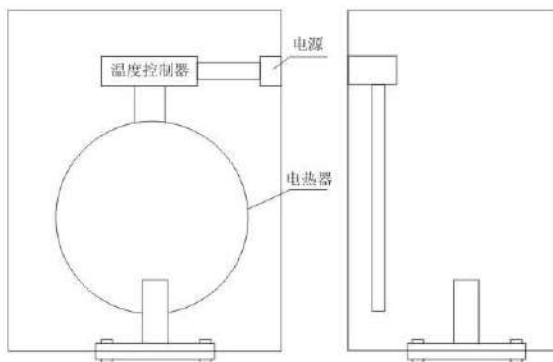

II、蒸汽管伴热:

蒸汽加热保温箱，伴热管是用金属管弯制成S型结构。箱体上下采用焊接式穿板接头与伴热管焊接而成，伴热管安装在箱内为上进下出，通过蒸汽在管腔内的循环而达到加热目的，伴热管材料规格分为两种，即Φ8×1紫铜管；Φ4×2无缝钢管(碳钢)。外形美观，其结构见图。

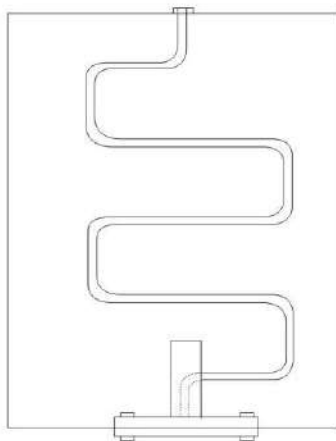

I、

TKYX_{WH} electric heating incubator consists case body of keater and instrument bracket. It's structure is the same as the protection box. The difference is the incubator is installed with the electric heater It's structure see the drawing the electric heater consists of electric heating pipes and temperature controller. the box has a socket on the side. After switching on the electric power, the electric heatre begin to work. When the temperature inside the box reach the needed temperature,the temperature controller cut off the electric power.When the temperature reduce to some degree, the temperature will switch on the electric power and the electric heater start to work again. Thus to keep the temperature in a setting range .

恒温加热器主要参数

1. 额定电压200V.50Hz。
2. 额定功率300-500W。
3. 控制温度由用户自定。
4. 恒温加热器可做成防爆型。
5. 电热管材料有三种：即铜管、碳钢管、不锈钢管。

Major targets of the thermostatic heater:

- 1.Rated voltage: 220V、50Hz
- 2.Rated frequency: 300~500W
- 3.Control temperature can be set by the user
- 4.The thermostatic heater may be the anti explosion type
- 5.The material of the electric heating pipe can be the following three types:cube pipe carbon steel pipe and stainless steel pipe.

II、

The accompanying heating pipe of the steam heating in cubator is "s" type.The box is welded by welded type threading joint andaccompanying heating pipe.The accompanying heating pipe inside the box is up-in and down-out type. Through the circulation of the steam in the pipe to achieve the goal of heating. The material of the accompanying heating pipe has two type: Φ8×1 red copper pipe and Φ14×2 seamless steel pipe (carbon steel). It's structure see the drawing .

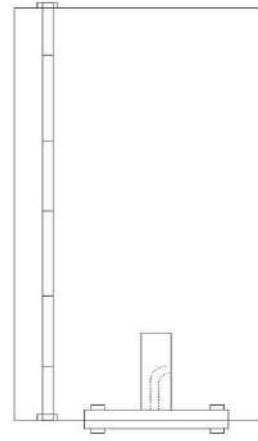

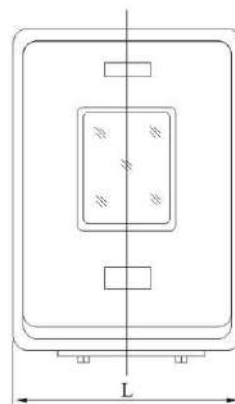
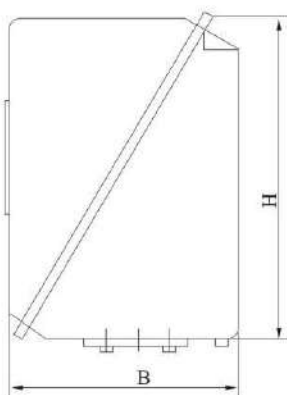
TKYX^H_W-A 型仪表保护 (保温) 箱 TKYX^H_W-A Gause Heat-proof and Protect Box

序号	型号	外型尺寸(mm)			内部净空尺寸(mm)		
		H	B	L	H	B	L
1	TKYXH-654A 型	640	500	408	570	480	390
2	TKYXH-665A 型	600	600	500	530	580	480
3	TKYXH-856A 型	800	500	600	730	480	580
4	TKYXH-866A 型	800	600	600	730	580	580
5	TKYXH-1056A 型	1000	500	600	930	480	580
6	TKYXH-1066A 型	1000	600	600	930	480	580
7	TKYXH-1256A 型	1200	500	600	1130	480	580
8	TKYXH-1266A 型	1200	600	600	1130	580	580

序号	型号	外型尺寸(mm)			内部净空尺寸(mm)		
		H	B	L	H	B	L
9	TKYXH-654A 型	640	500	408	570	480	390
10	TKYXH-665A 型	600	600	500	530	580	480
11	TKYXH-856A 型	800	500	600	730	480	580
12	TKYXH-866A 型	800	600	600	730	580	580
13	TKYXH-1056A 型	1000	500	600	930	480	580
14	TKYXH-1066A 型	1000	600	600	930	480	580
15	TKYXH-1256A 型	1200	500	600	1130	480	580
16	TKYXH-1266A 型	1200	600	600	1130	580	580

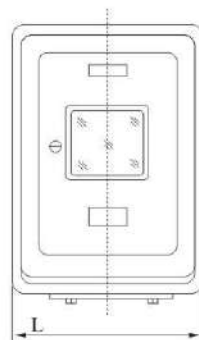
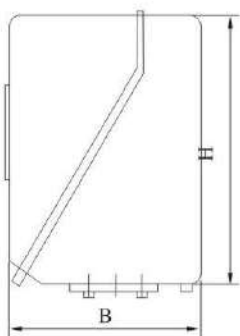
TKYX^H_W-B 型仪表保护 (保温) 箱 TKYX^H_W-B Gause Heat-proof and Protect Box

序号	型号	外型尺寸(mm)			内部净空尺寸(mm)		
		H	B	L	H	B	L
1	TKYXH-654B 型	640	500	408	570	480	390
2	TKYXH-656B 型	600	500	600	530	480	580
3	TKYXH-666B 型	800	600	600	530	580	580
4	TKYXH-856B 型	800	500	600	730	480	580
5	TKYXH-866B 型	1000	600	600	730	580	580
6	TKYXH-1056B 型	1000	600	600	930	480	580
7	TKYXH-1066B 型	1200	600	600	930	580	580
8	TKYXH-1256B 型	1200	500	600	1130	480	580

序号	型号	外型尺寸 (mm)			内部净空尺寸(mm)		
		H	B	L	H	B	L
9	TKYXH ₀ -654B 型	640	500	408	570	480	390
10	TKYXH ₀ -656B 型	600	500	600	530	480	480
11	TKYXH ₀ -856B 型	800	500	600	730	480	580
12	TKYXH ₀ -866B 型	800	600	600	730	580	580
13	TKYXH ₀ -1056B 型	1000	500	600	930	480	580
14	TKYXH ₀ -1066B 型	1000	600	600	930	580	580
15	TKYXH ₀ -1256B 型	1200	500	600	1130	480	580

TKYX_W^H-C 型仪表保护 (保温) 箱 TKYX_W^H-C Gause Heat-proof and Protect Box

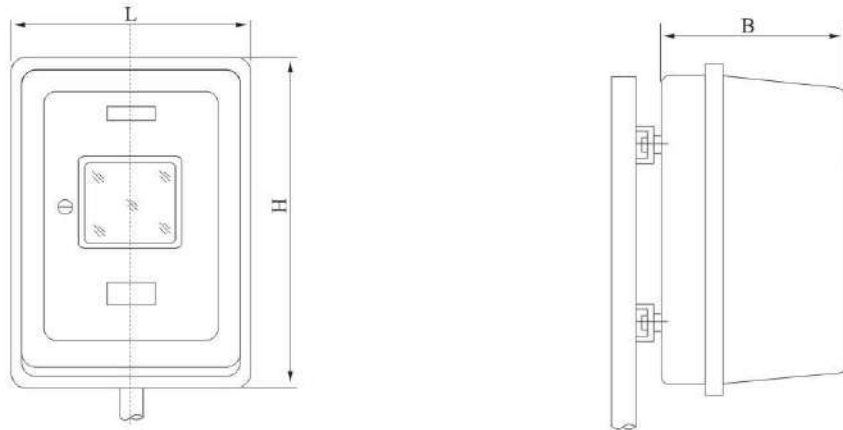

序号	型号	外型尺寸(mm)			内部净空尺寸(mm)		
		H	B	L	H	B	L
1	TKYXH-656C型	600	500	500	560	480	460
2	TKYXH-856C型	800	500	600	760	480	560
3	TKYXH-866C型	800	600	600	760	580	560
4	TKYXH-1056C型	1000	500	600	960	480	560
5	TKYXH-1066C型	1000	600	600	960	580	560
6	TKYXH-1256C型	1200	500	600	1150	480	550

序号	型号	外型尺寸(mm)			内部净空尺寸(mm)		
		H	B	L	H	B	L
7	TKYXH ₀ ⁰ -655C型	600	500	500	560	480	460
8	TKYXH ₀ ⁰ -856C型	800	500	600	760	480	560
9	TKYXH ₀ ⁰ -866C型	640	600	600	760	580	560
10	TKYXH ₀ ⁰ -1056C型	1000	500	600	960	480	560
11	TKYXH ₀ ⁰ -1066C型	1000	600	600	960	580	560
12	TKYXH ₀ ⁰ -1256C型	1200	500	600	1150	480	550

TKYX_W^H-D 型仪表保护 (保温) 箱 TKYX_W^H-D Gause Heat-proof and Protect Box

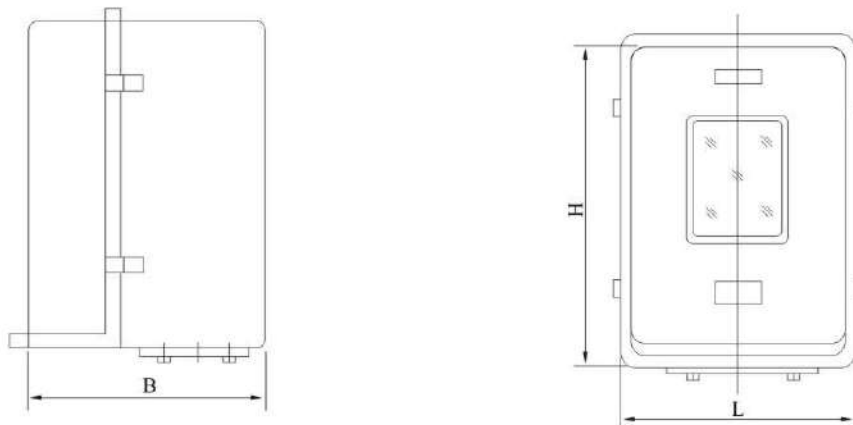

序号	型号	外型尺寸(mm)			内部净空尺寸(mm)		
		H	B	L	H	B	L
1	TKYXH-756D型	700	500	600	680	480	480
2	TKYXH-856D型	800	500	600	780	480	580
3	TKYXH-866D型	800	600	600	780	580	580
4	TKYXH-1066D型	1000	500	600	980	480	580
5	TKYXH-1066D型	1000	600	600	980	580	580
6	TKYXH-1256D型	1200	500	600	1170	480	570

序号	型号	外型尺寸(mm)			内部净空尺寸(mm)		
		H	B	L	H	B	L
7	TKYXH ₀ ⁰ -756D型	700	500	600	680	480	580
8	TKYXH ₀ ⁰ -856D型	800	500	600	780	480	580
9	TKYXH ₀ ⁰ -866D型	800	600	600	780	580	580
10	TKYXH ₀ ⁰ -1056D型	1000	500	600	980	480	580
11	TKYXH ₀ ⁰ -1066D型	1000	600	600	980	580	580
12	TKYXH ₀ ⁰ -1256D型	1200	500	600	1170	480	570

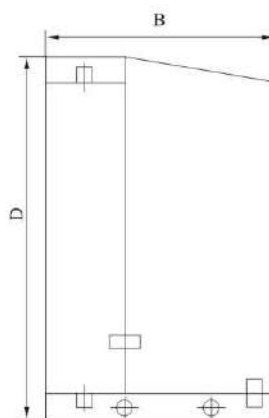
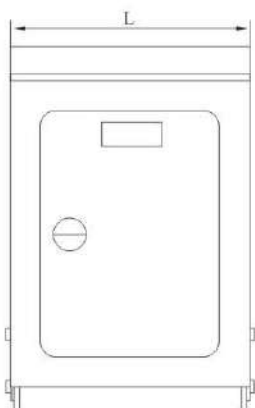
TKYX_W^H-E 型仪表保护 (保温) 箱 TKYX_W^H-E Gause Heat-proof and Protect Box

序号	型号	外型尺寸(mm)			内部净空尺寸(mm)		
		H	B	L	H	B	L
1	TKYXH-654E型	600	500	410	560	460	370
2	TKYXH-666E型	600	600	500	530	580	480
3	TKYXH-856E型	800	500	600	760	460	560
4	TKYXH-866E型	800	600	600	760	560	560
5	TKYXH-1056E型	1000	600	600	960	460	560
6	TKYXH-1066E型	1000	600	600	690	560	560
7	TKYXH-1256E型	1200	500	600	1160	460	560

序号	型号	外型尺寸(mm)			内部净空尺寸(mm)		
		H	B	L	H	B	L
8	TKYXH _D ^D -654E型	600	500	410	540	460	370
9	TKYXH _D ^D -665E型	600	500	500	530	580	480
10	TKYXH _D ^D -856E型	800	500	600	740	460	565
11	TKYXH _D ^D -866E型	800	600	600	740	560	565
12	TKYXH _D ^D -1056E型	1000	500	600	940	460	565
13	TKYXH _D ^D -1066E型	1000	600	600	940	560	565
14	TKYXH _D ^D -1256E型	1200	500	600	1140	460	365

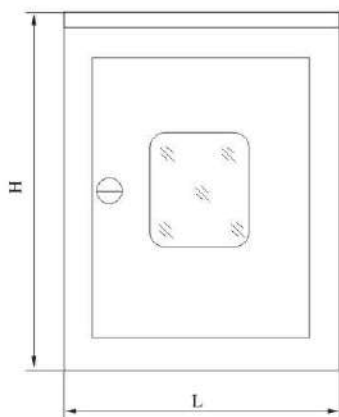
TKYX_W^H-F 型仪表保护 (保温) 箱 TKYX_W^H-F Gause Heat-proof and Protect Box

序号	型号	外型尺寸(mm)			内部净空尺寸(mm)		
		H	B	L	H	B	L
1	TKYXH-854F型	600	500	410	550	470	405
2	TKYXH-856F型	800	500	600	750	470	595
3	TKYXH-866F型	800	600	600	750	570	595
4	TKYXH-1056F型	1000	500	600	950	470	595
5	TKYXH-1066F型	1000	600	600	950	570	595
6	TKYXH-1256F型	1200	500	600	1150	470	595
7	TKYXH-1266F型	1200	600	600	1150	570	595

序号	型号	外型尺寸(mm)			内部净空尺寸(mm)		
		H	B	L	H	B	L
8	TKYXH _D ^D -856F型	800	500	600	750	470	595
9	TKYXH _D ^D -866F型	800	600	600	750	570	595
10	TKYXH _D ^D -1056F型	1000	500	600	950	470	595
11	TKYXH _D ^D -1066F型	1000	600	600	950	570	595
12	TKYXH _D ^D -1256F型	1200	500	600	1150	470	595
13	TKYXH _D ^D -1266F型	1200	600	600	1150	570	595

TKYX^H_W-G型仪表保护(保温)箱 TKYX^H_W-G Gause Heat-proof and Protect Box

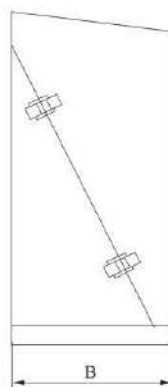
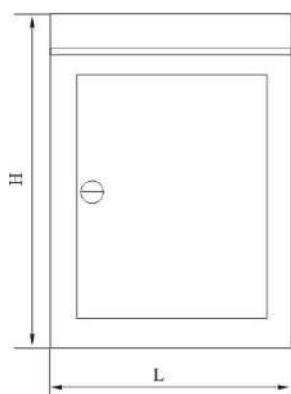

序号	型号	外型尺寸(mm)			内部净空尺寸(mm)		
		H	B	L	H	B	L
1	TKYXH-856G型	800	500	600	700	495	590
2	TKYXH-866G型	800	600	600	700	595	590
3	TKYXH-1056G型	1000	500	600	900	495	590
4	TKYXH-1066G型	1000	600	600	900	595	590
5	TKYXH-1256G型	1200	500	600	1100	495	590
6	TKYXH-1266G型	1200	600	600	1100	595	590

序号	型号	外型尺寸(mm)			内部净空尺寸(mm)		
		H	B	L	H	B	L
7	TKYXH ₀ -856G型	800	500	600	650	445	540
8	TKYXH ₀ -866G型	800	600	600	650	545	540
9	TKYXH ₀ -1056G型	1000	500	600	850	445	540
10	TKYXH ₀ -1066G型	1000	500	600	850	545	540
11	TKYXH ₀ -1256G型	1200	500	600	1050	445	540
12	TKYXH ₀ -1266G型	1200	600	600	1050	545	540

TKYX^H_W-I型仪表保护(保温)箱 TKYX^H_W-I Gause Heat-proof and Protect Box

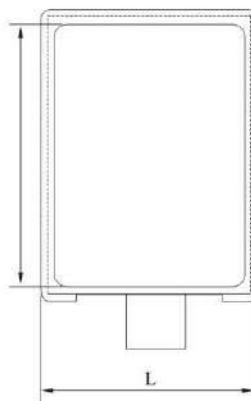
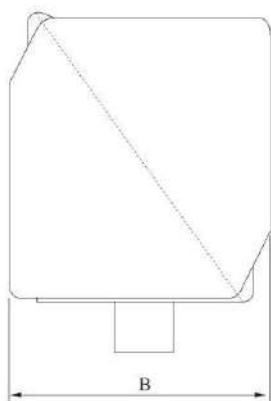

TKYX-I系列仪表保护(保温)箱,是根据国外同类产品的最新结构形式设计的,其材料为玻璃钢,它与TKYX-A型仪表保护(保温)箱相比,具有外形美观、结构小巧、重量轻、互换性强等特点。其上下箱体结构尺寸完全相同,可以互换。上、下箱体采用铰链连接,并装有搭扣,箱内装有撑杆,以支撑箱盖。若需打开箱盖,只要松开搭扣,将上箱体向上掀起90°即可,便于箱内仪表安装及调修。该结构形式的保温(保护)箱适用于仪表二阀组、三阀组、五阀组与压力变送器、差压变送器、压力表、压力开关等仪表配套使用。仪表阀组可直接与保温

箱底面或侧面相连接,可省去箱内安装板和安装支柱,缩小了保温箱体积。保温箱内的加热方式可分为电加热和蒸汽拌热两种,蒸汽拌热以可分为直接将阀体作为散热体拌热和蒸汽散热管拌热。这种安装方式将箱内元件更加合理地安装在一起,因此所需保温箱的体积可大大缩小。

序号	型号	外型尺寸(mm)			内部净空尺寸(mm)			备注
		H	B	L	H	B	L	
1	TKYXH-444G型	450	450	410	425	400	405	
2	TKYXH-655G型	630	550	578	600	500	570	
3	TKYXH-685G型	630	850	578	600	800	570	供多台仪表一同安装用

TK6 系列气动管路截止阀

TK6 Pneumatic Tube Stop Valve

TK6-1 QJ-1 型气动管路截止阀
TK6-1 QJ-1 Pneumatic Tube Stop Valve

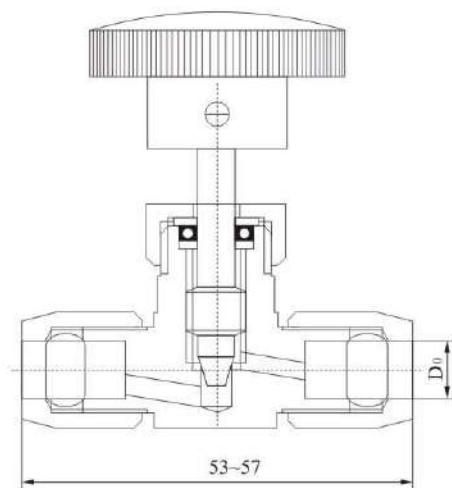

材料Material	T62
公称压力	PN1.0 Mpa
配管 Do	Φ6、Φ8、Φ10、Φ1/4"~Φ3/8"

TK6-2 QJ-2A 型气动管路截止阀
TK6-2 QJ-2A Pneumatic Tube Stop Valve

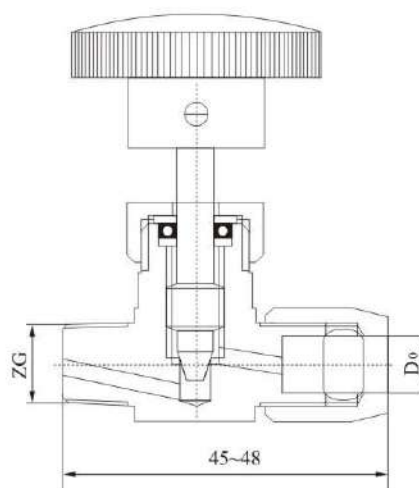

材料Material	T62
公称压力	PN1.0 Mpa
配管 Do	Φ6、Φ8、Φ10、Φ1/4"~Φ3/8"
终端螺纹d	ZG、NPT(1/8~1/4)

TK6-3 QJ-2A 型气动管路截止阀
TK6-3 QJ-2A Pneumatic Tube Stop Valve

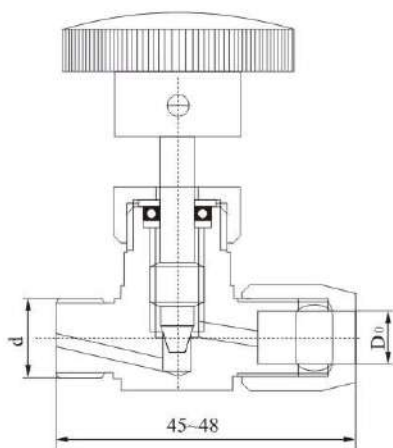

材料Material	T62
公称压力	PN1.0 Mpa
配管Do	Φ6、Φ8、Φ10、Φ1/4"~Φ3/8"
终端螺纹	d:M10×1、M12×1.25

TK6-4 QJ-3A 型气动管路截止阀
TK6-4 QJ-3A Pneumatic Tube Stop Valve

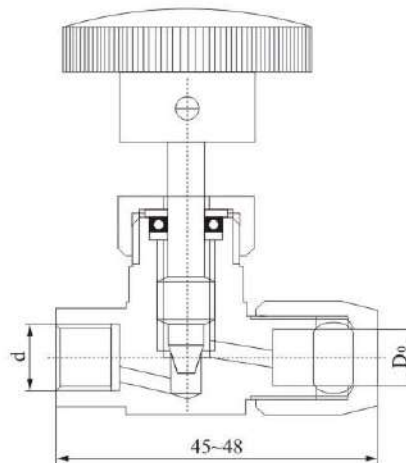

材料Material	T62
公称压力	PN1.0 Mpa
配管 Do	Φ6、Φ8、Φ10、Φ1/4"~Φ3/8"
终端螺纹d	M10×1

TK6-5 QJ-3B 型气动管路截止阀
TK6-5 QJ-3B Pneumatic Tube Stop Valve

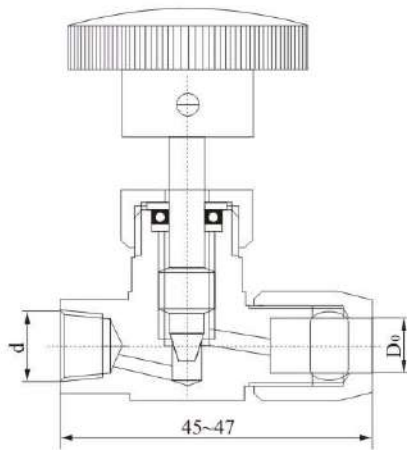

材料Material	T62
公称压力	PN1.0 Mpa
配管 Do	Φ6~Φ10、Φ1/4"~Φ3/8"
终端螺纹 d	ZG、NPT(1/8"~1/4")

TK6-6 QJ-4A 型气动管路截止阀
TK6-6 QJ-4A Pneumatic Tube Stop Valve

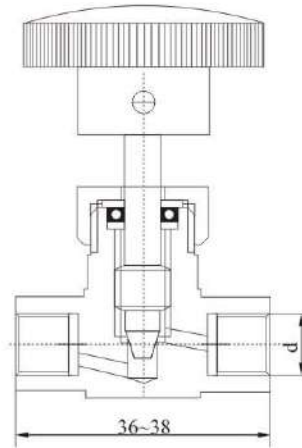

材料Material	T62
公称压力	PN1.0 Mpa
配管 d	M10×1、M12×1
终端螺纹	ZG、NPT (1/8"、1/4")

TKG6-7 QJ-5A 型气动管路截止阀
TKG6-7 QJ-5A Pneumatic Tube Stop Valve

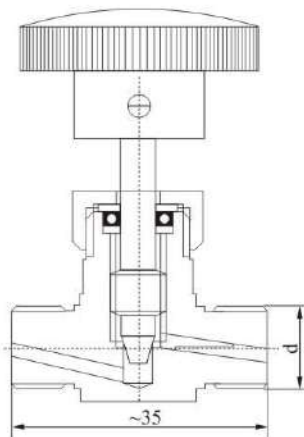

材料Material	T62
公称压力	PN1.0 Mpa
终端螺纹d	M10×1、M12×1.25

TKG6-8 QJ-5B 型气动管路截止阀
TKG6-8 QJ-5B Pneumatic Tube Stop Valve

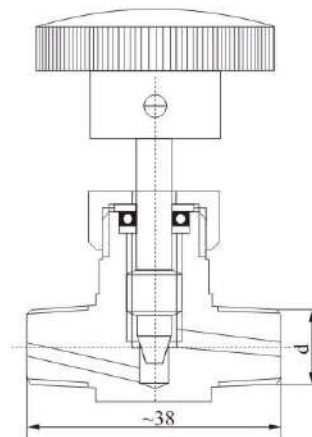

材料Material	T62
公称压力	PN1.0 Mpa
终端螺纹d	ZG、NPT(1/8"~1/4")

TK6-9 QJ-6A 型气动管路截止阀
TK6-9 QJ-6A Pneumatic Tube Stop Valve

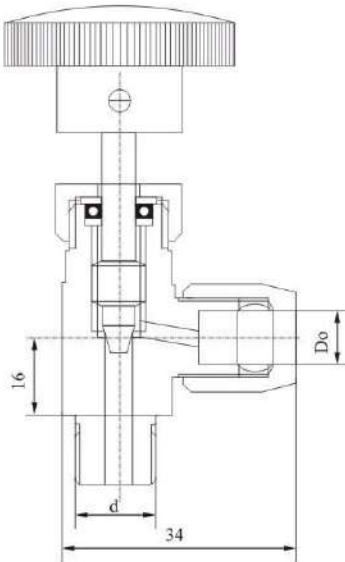

材料Material	T62、1Cr18Ni9Ti
公称压力	PN1.0 Mpa PN2.5MPa
配管 Do	Φ6~Φ10、Φ1/4"~Φ3/8"
终端螺纹 d	M10×1、M14×1.5、M16×1.5、G、ZG、NPT(1/8"~1/4")

TK10-17 JE.QY1 型气动管路截止阀
TK10-17 JE.QY1 Pneumatic Tube Reducing Stop Valve

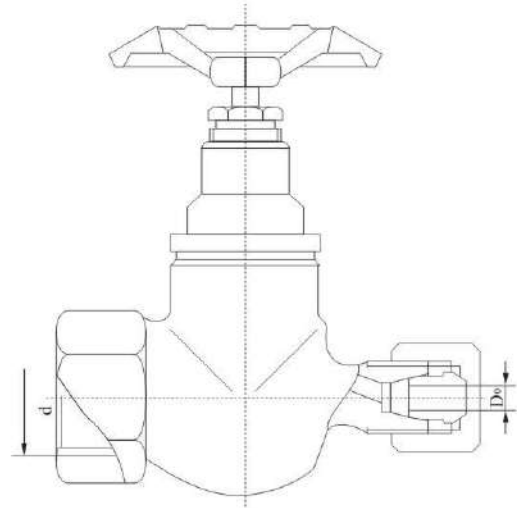

材料Material	T62
公称压力	PN1.0 Mpa
配管Do Φ6~Φ8 d	NPT1/2"、G 1/2"、ZG1/2"

TK12-1 QZ-1 型双卡套针形阀
TK12-1 QZ-1 QZ-1 Double-collet Needle Valve

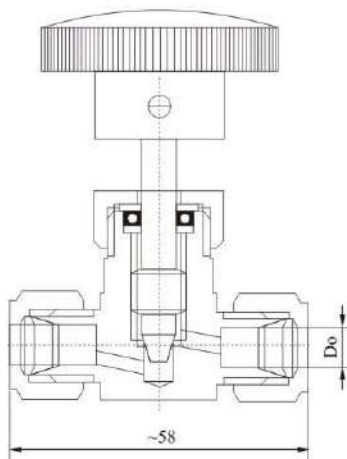

材料Material	T62 1Cr18Ni9Ti
公称压力	PN2.5 Mpa
公称口径	DN4
配管 Do	Φ6~Φ8、Φ1/4"、Φ3/8"

TK12-2 QZ-2 型双卡套针形阀
TK12-2 QZ-2 Double-collet Needle Valve

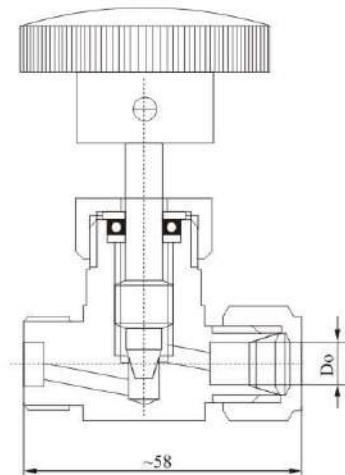

材料Material	T62 1Cr18Ni9Ti
公称压力	PN2.5 Mpa
公称口径	DN4
终端螺纹d	M10×1、12×1.25 ZG、G、NPT (1/8"、1/4")
配管 Do	Φ6、Φ8、Φ1/4"、Φ3/8"

TK12-3 QZ-3 型双卡套针形阀
TK12-3 QZ-3 Double-collet Needle Valve

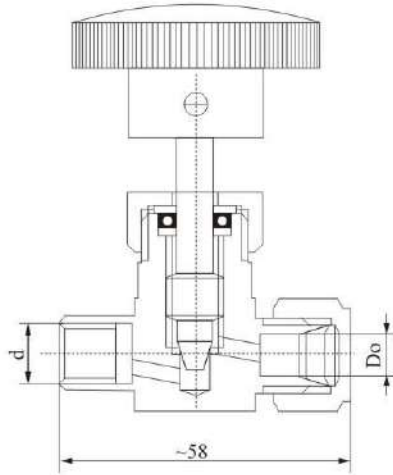

材料Material	T62
公称压力	PN2.5MPa
公称通径	DN 4
配管 Do	Φ6、Φ8、Φ1/4"、Φ3/8"
终端螺纹	M10×1、G、ZG、NPT1/8"、1/4"

TK12-4 QZ-4 型双卡套针形阀
TK12-4 QZ-4 Male Screw Needle Valve

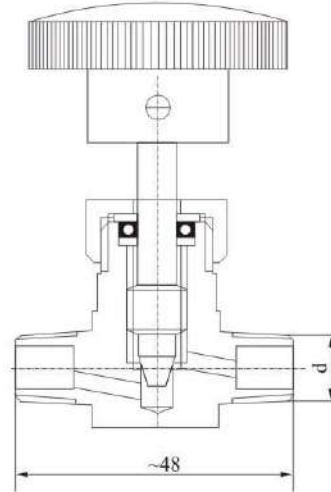

材料Material	T62 1Cr18Ni9Ti
公称压力	PN2.5 Mpa
公称通径	DN4
配管Do	Φ6~Φ8、Φ1/4"、Φ1/8"
终端螺纹	M10×1、G、ZG、NPT1/8"、3/4"

TK12-21 QE-1 气动管路截止阀 **TK12-22 QE-2 气动管路三通截止阀** **TK12-41 QE-3 气动管路角式截止阀**
TK12-21 QE-1 Pneumatic Tube Stop Valve **TK12-22 QE-2 Pneumatic Tube Stop Valve** **TK12-41 QE-3 QE-3 PanPneumatic Tube Stop Valve**

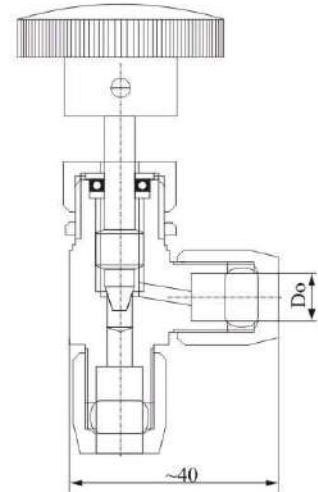
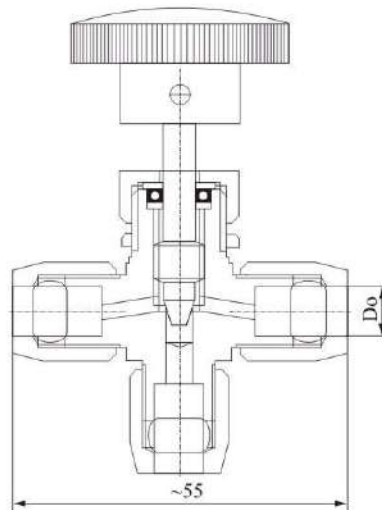
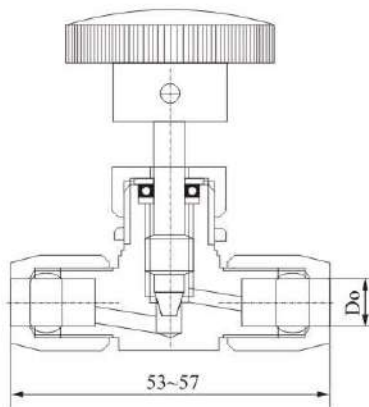

材料Material	T62
公称压力	PN1.0Mpa
公称通径	DN4
配管 Do	Φ6~Φ8 Φ 1/4"、Φ 3/8"

材料Material	T62
公称压力	PN1.0 Mpa
公称通径	DN(3、4)
配管 Do	Φ6~Φ8、Φ1/4"、Φ3/8

材料Material	T62
公称压力	PN1.0 Mpa
公称通径	DN4
配管 Do	Φ3 Φ6、Φ8、Φ10、Φ12

TK7 系列气动管路截止阀 (塑料管用)

TK7 Pneumatic Tube Stop Valve (made of plastic)

TK 7-1 SQJ-1 型气动管路截止阀

TK 7-1 SQJ-1 Pneumatic Tube Stop Valve

TK 7-2,3 SQJ-2 型气动管路截止阀

TK 7-2,3 SQJ-2 Pneumatic Tube Stop Valve

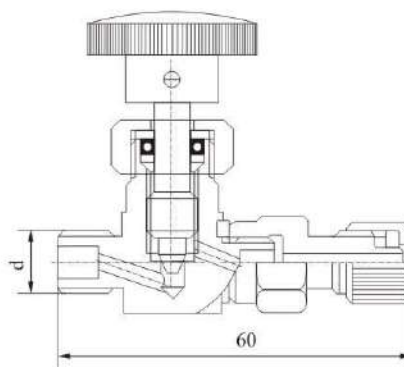
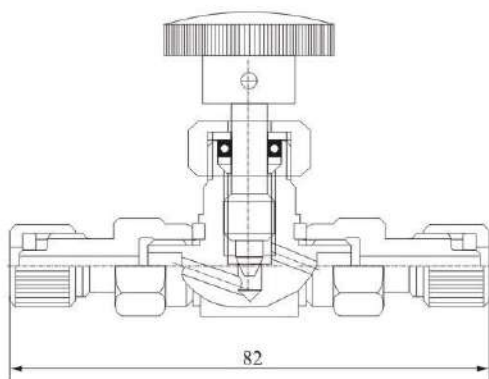

材料Material	T62
配管	$\Phi 48 \times 1$ 、 $\Phi 6 \times 1$
公称压力	PN1.0MPa

材料Material	T62
配管	$\Phi 8 \times 1$ 、 $\Phi 6 \times 1$ $\Phi 6 \times 1$
终端螺纹 d	M10 \times 1、ZG1/8"、ZG1/4"
公称压力	PN1.0MPa

TK 7-4,5 SQJ-3 型气动管路截止阀

TK 7-4,5 SQJ-3 Pneumatic Tube Stop Valve

TK 7-6 SQJ-4 型气动管路截止阀

TK 7-6 SQJ-4 Pneumatic Tube Stop Valve

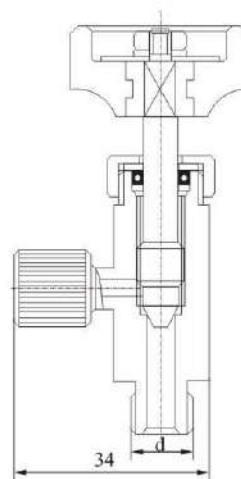
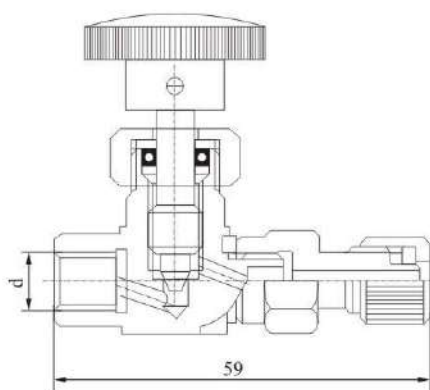

材料Material	T62
配管	D \times 8、 $\Phi 8 \times 1$ 、 $\Phi 6 \times 1$ "
终端螺纹 d	M10 \times 1、G1/4"、ZG1/8"、ZG1/4"
公称压力	PN1.0Mpa

材料Material	T62
配管	$\Phi 8 \times 1$ 、 $\Phi 6 \times 1$
终端螺纹	M10 \times 1、M14 \times 1.5、M16 \times 1.5 G1/8"、G1/4"、ZG1/8"、ZG1/4"
公称压力	PN1.0Mpa

TK 7-7 SQJ-4B 型气动管路截止阀

TK 7-7 SQJ-4B Pneumatic tube Stop Valve

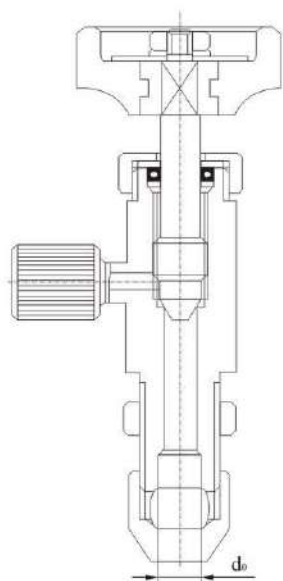

材料Material	T62
配管	Φ8×1、Φ6×1
公称压力	PN1.0MPa
注 Remarks	d0 端接铜管Φ6、Φ8

TK 7-8 SQJ-5A 型气动管路截止阀

TK 7-8 SQJ-5A Pneumatic tube Stop Valve

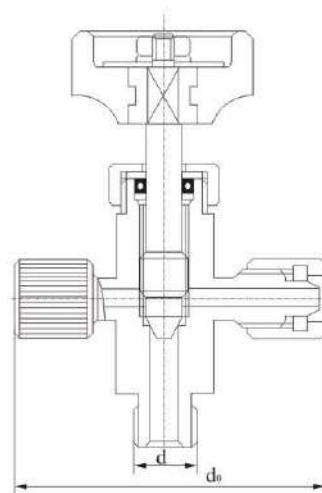

材料Material	T62
配管	Φ8×1、Φ6×1"Φ6×1
终端螺纹 d	M10×1、M14×1.5、M16×1.5、 ZG1/4"、ZG1/4"、ZG1/8"、ZG1/4"
公称压力	PN1.0MPa

TK 7-9 SQJ-5B 型气动管路截止阀

TK 7-9 SQJ-5B Pneumatic Tube Stop Valve

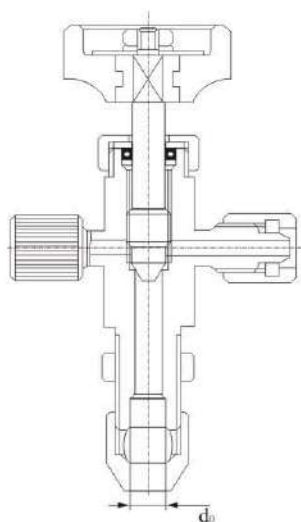

材料Material	T62
配管	Φ8×1、Φ6×1
d0端接铜管	Φ6、Φ8
公称压力	PN1.0Mpa

TK 7-10 SQJ-6 型气动管路截止阀

TK 7-10 SQJ-6 Pneumatic Tube Stop Valve

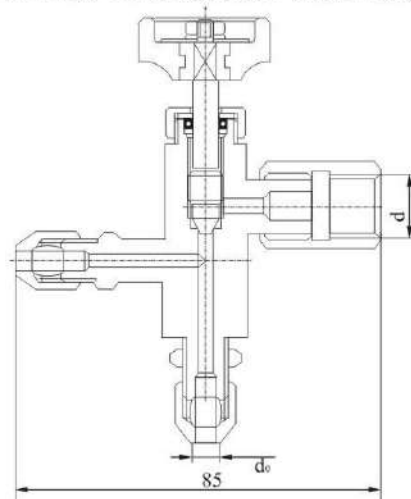

材料Material	T62
配管	Φ6×1、Φ8×1
螺纹 d	M10×1、M12×1.25、M14×1.5
d0接铜管	Φ6、Φ8
公称压力	PN1.0Mpa

TKJ 系列测量管路截止阀

TKJ Measurement Tube Stop Valve

TKJ-1A J91 型卡套截止阀

TKJ-1A J91 Collet-type Stop Valve

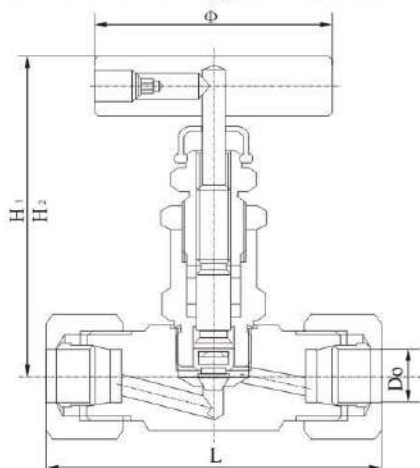

序号	公称通径	公称压力	配管外径	外形尺寸				制造材料
	DN	PN(MPa)	Do	L	Φ	H ₁	H ₂	
1	5	6.4	Φ12	80	45	72	66	20° 1Cr18Ni9Ti 0Cr18Ni12 Mo2Ti 304L 316L
2			Φ14	80	45	72	66	
3		20	Φ12	82	46	72	66	
4			Φ14	82	45	72	66	
5		40	Φ12	88	60	79	73	
6			Φ14	88	60	79	73	

TKJ-1B J91 型卡套截止阀

TKJ-1B J91 Collet-type Stop Valve

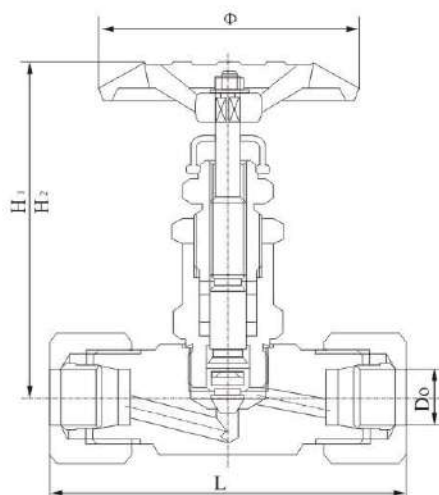

序号	公称通径	公称压力	配管外径	外形尺寸				制造材料
	DN	PN(MPa)	Do	L	Φ	H ₁	H ₂	
1	10	6.4	Φ14	88	26	100	94	20° 1Cr18Ni9Ti 0Cr18Ni12 Mo2Ti 304L 316L
2		16						
3		32						

TKJ-1C J91 型卡套截止阀

TKJ-1C J91 Collet-type Stop Valve

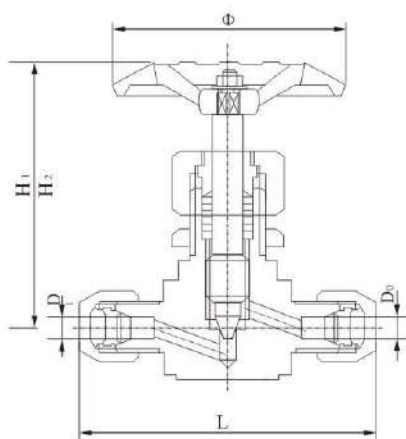

序号	公称通径	公称压力	配管外径		外形尺寸				制造材料
	DN	PN(MPa)	D ₀	D ₁	L	Φ	H ₁	H ₂	
1	5	25	Φ6	Φ8	70	50	80	74	20° 1Cr18Ni9Ti 0Cr18Ni12 Mo2Ti 304L 316L
2			Φ8	Φ8					
3			Φ8	Φ6					

TKJ-1D J94 型卡套角式截止阀

TKJ-1D J94 Collet-type Angle Patten Stop Valve

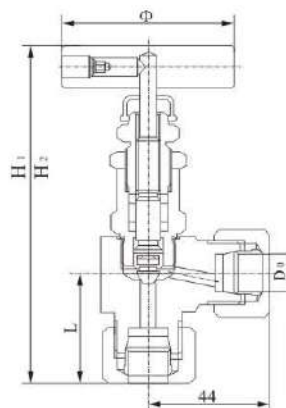

序号	公称通径	公称压力	配管外径	外形尺寸				制造材料
	DN	PN(MPa)	Do	L	Φ	H ₁	H ₂	
1	3	6.4	Φ14	44	74	144	134	20° 1Cr18Ni9Ti 0Cr18Ni12 Mo2Ti 304L 316L
2		16						
3	6	6.4						
4		16						
5	10	6.4						
6		16						

TKJ-2A J21 W 型外螺纹截止阀
TKJ-2A J21 W Male Screw Stop Valve

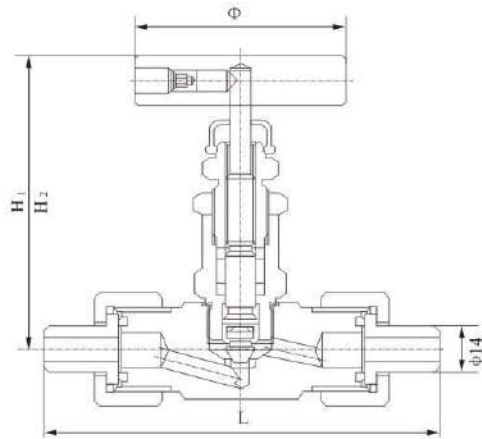

序号 No	公称压力 PN(MPa)	公称口径 DN	外形尺寸				制造 材料
			L	t	H ₁	H ₂	
1	6.4	5	126	45	72	66	20,1Cr18Ni9Ti 0Cr18Ni12 Mo2Ti,304L 316L
2	20		126	45	72	66	
3	40		132	60	29	73	

TKJ-2B J21 W 型外螺纹截止阀
TKJ-2B J21 W Male Screw Stop Valve

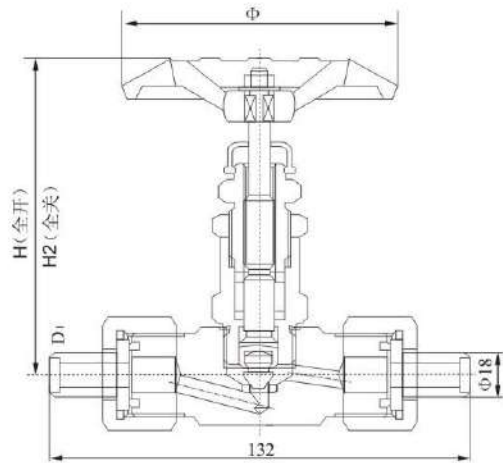

序号 No	公称口径 DN	公称压力 PN(MPa)
1	15	6.4
2	20	16
3	25	32

TKJ-2C J21 W 型外螺纹截止阀
TKJ-2C J21 W Male Screw Stop Valve

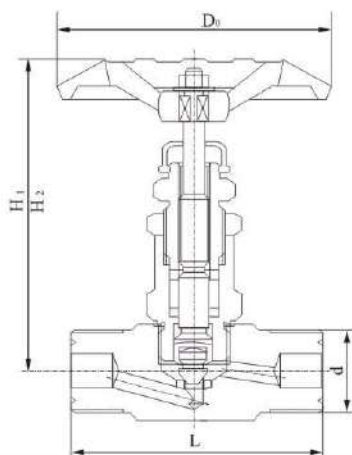

序号 No	公称口径 DN	公称压力 PN(MPa)	外形尺寸				
			d	L	H ₁	H ₂	D ₀
1	5	2.5 4.0 6.4	G1/2"	64	72	66	45
2	10		G3/4"	90	100	94	100
3	15		G1"	110	158	143	100

TKJ-2D J24 型外螺纹角式截止阀
TKJ-2D J24 Male and Angle Pattern Stop Valve

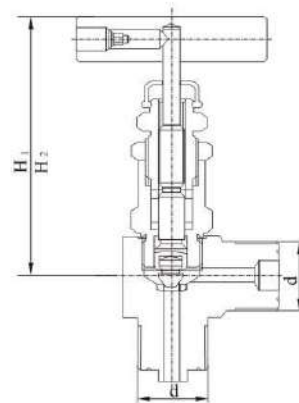

序号 No	公称口径 DN	公称压力 PN(MPa)	外形尺寸						
			d	L	D	h	H ₁	H ₂	D ₀
1	6	2.5 4.0 6.4	G1/2"	32	10.5	37	72	66	45
2	10		G3/4"	48	14.5	53	100	94	76

TKJ-2E J24 型外螺纹角式截止阀
TKJ-2E J24 Male and Pattern Stop Valve

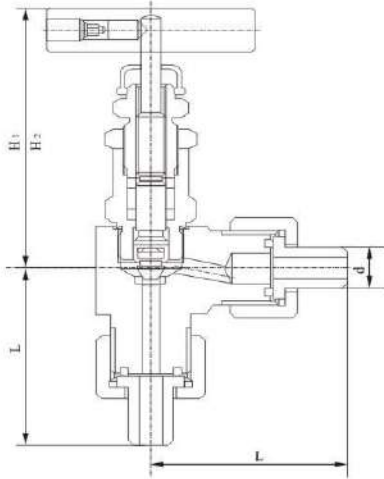

序号 NO	公称 口径 DN	公称压力 PN(MPa)	d	L	H ₁	H ₂	L
1	3	16	14	64	99	93	76
2		32					
3	5	16	14	64	99	93	76
4		32					
5	10	16	14/18	66	101	87	76
6		32					

TKJ-2F J24 型外螺纹角式截止阀
TKJ-2F J24 Male and Pattern Stop Valve

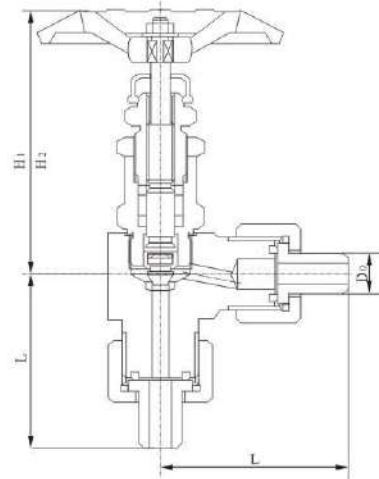

序号 NO	公称 口径 DN	公称压力 PN(MPa)	D ₀	L	H ₁	H ₂
1	15	6.4	22	93	63	37
2		16				
3	20	2.5	28	108	77	57
4		6.4				
5	25	2.5	34	127	87	77
6		6.4				

TKJ-3A J11 型内螺纹截止阀
TKJ-3A J11 Femals Screw Stop Valve

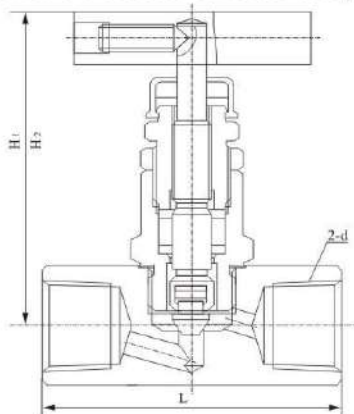

序号 NO	公称 口径 DN	公称压力 PN(MPa)	接头螺纹 d	L	H ₁	H ₂
1	5	4	1/2"	48	72	66
2			1/4"	48	72	66
3	5	6.4	1/2"	48	72	66
4			1/4"	56	72	66
5	5	20	1/2"	64	72	66
6			1/4"	56	79	66
7			1/8"	56	79	66
8			1/2"	64	79	66

TKJ-3B J11 型内螺纹截止阀
TKJ-3B J11 Femals Screw Stop Valve

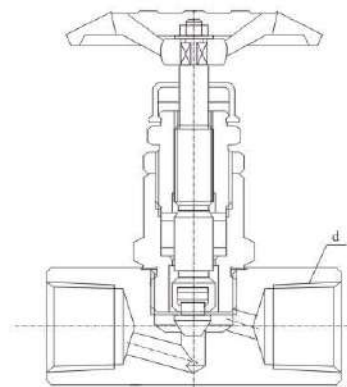

序号 NO	公称压力 PN(MPa)	公称口径 DN	接头螺纹 d
1	16	15	1/2"
2		10	1/4"
3	6.4	15	1/2"
4		10	1/4"
5	25	15	1/2"
6		20	3/4"
7	32	15	1/2"

TKJ-3C J11W-16T 型内螺纹铜制截止阀
TKJ-3C J11W-16T Female copper Stop Valve

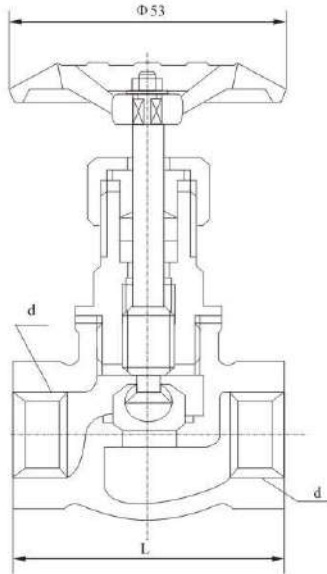

序号	公称压力 PN	公称口径	d	L
1	1.6MPa	10	1/4"	50
2		15	1/2"	65

TKJ-4 J¹/₂ 1 型内螺纹铜制截止阀
TKJ-4 J¹/₂ 1 Female and Male Screw Stop Valve

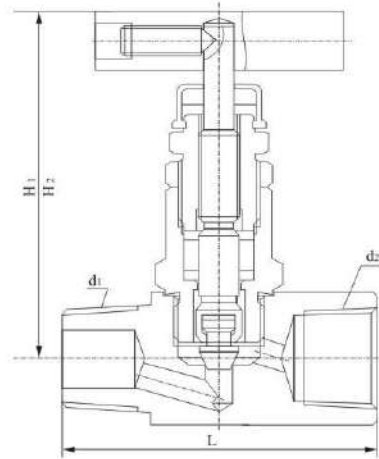

序号	公称口径 DN	公称压力 PN	d ₁	d ₂	L	H ₁	H ₂
1	5	20MPa	1/4"	1/4"	48	72	72
2	5	40MPa	1/4"	1/4"	56	79	73
3	5	40MPa	3/8"	3/8"	56	79	73
4	5	40MPa	1/2"	1/2"	64	79	73

TKJ-5 J11 型压力表截止阀
TKJ-5 J11 Pressure Gauge Stop Valve

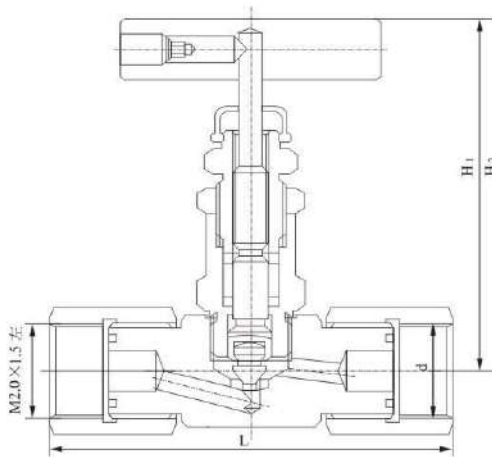

序号 NO	公称口径 DN	公称压力 PN(MPa)	接头螺纹 d	L	t	H ₁	H ₂
1	5	20	M20×1.5	86	45	72	66
2	5	20	G1/2"	86	45	72	66
3	5	40	M20×1.5	92	60	79	73
4	5	40	G1/2"	92	60	79	73

TKJ-6 J11 型节流截止阀
TKJ-6 J11 Throttle Stop Valve

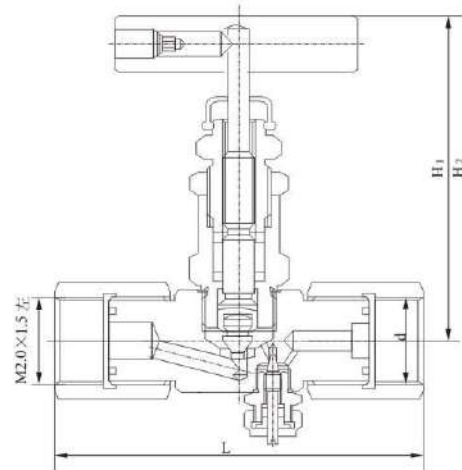

序号 NO	公称口径 DN	公称压力 PN(MPa)	接头螺纹 d	L	H ₁	H ₂
1	5	20	M20×1.5	90	72	66
2	5	20	G1/2"	90	72	66
3	5	40	M20×1.5	96	79	73
4	5	40	G1/2"	96	79	73

TKJ1-7 J_{4/9} 1型取压截止阀
TKJ1-7 J_{4/9} 1 Pressure-taking Stop Valve

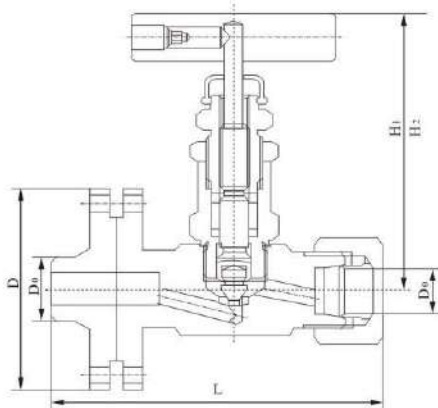

序号 NO	公称 口径 DN	公称 压力 PN	配管直径		D	L	H ₁	H ₂
			D ₀	D ₀ '				
1	5	20MPa	Φ14	Φ12	Φ75	116	72	66
2	5	20MPa	Φ14	Φ14	Φ75	116	79	73
3	5	40MPa	Φ14	Φ12	Φ75	116	79	73
4	5	40MPa	Φ14	Φ14	Φ75	116	79	73
5	5	40MPa	Φ14	Φ12	Φ75	116	79	73
6	5	40MPa	Φ18	Φ14	Φ85	122	79	73

TKJ1-8 J_{1/2} 1型排泄截止阀
TKJ1-8 J_{1/2} 1 Exhaust stop Valve

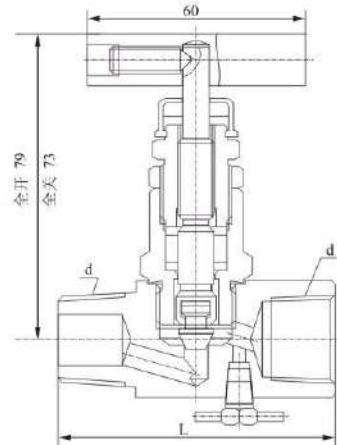

序号 NO	公称 口径 DN	公称 压力 PN	接头螺纹 unionbonnetd
1	5	20MPa	1/2"
2	5	20MPa	3/4"
3	5	40MPa	Z1/2"
4	5	40MPa	Z3/4"

TKJ-9A JG-1F型多口计量阀
TKJ-9A JG-1F Polymouth Metering Valve

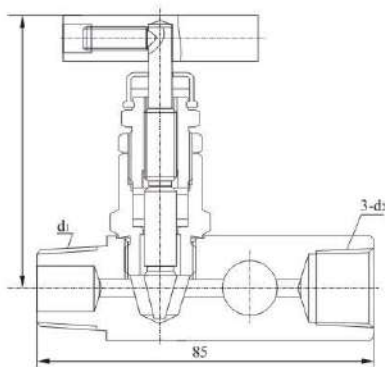

该阀有一个凸形螺纹进口和三个凹形螺纹出口。出口位于三个不同方向，根据现场仪表安装需要，可分别与压力计或压力开关相连接，用于计量管道流量等。

This valve has one raised screw inlet and three sunken screw exits. The three exits which are in different directions can be separately connected with the manometer or the pressure switch and used in the metering tube flow.

序号 NO	公称 口径 DN	公称 压力 PN	接头螺纹 unionbonnet	
			d ₁	d ₂
1	5	20MPa	Z1/2"	
2	5	20MPa	Z1/8"	M20×1.5
3	5	40MPa	Z1/4"	G1/2"
4	5	40MPa	Z1/2"	Z1/2"
5	5	40MPa	Z3/4"	M20×1.5
6	5	40MPa		G1/2"

TKJ-9B JG-2F型多口计量阀
TKJ-9B JG-2F Polymouth Metering Valve

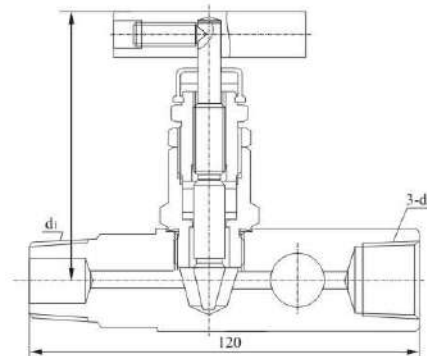

该阀的作用与 JG-1F 型基本相同，不同之处为该阀凸形接口较长。可以提供 50mm 长内滞后空隙。

Its function is basically the same as the JG-1F and the difference is the raised connector of this valve is longer and can supply the sluggish of 50mm.

序号 NO	公称 口径 DN	公称 压力 PN	接头螺纹 unionbonnet	
			d ₁	d ₂
1	5	20MPa	Z1/4"	Z1/2"
2	5	20MPa	Z3/8"	M20×1.5
3	5	20MPa		G1/2"
4	5	40MPa	Z1/2"	Z1/2"
5	5	40MPa	Z3/4"	M20×1.5
6	5	40MPa		G1/2"

TKJ-10A J29 型压力计用截止阀
TKJ-10A J29 Pressure Gauge Stop Valve

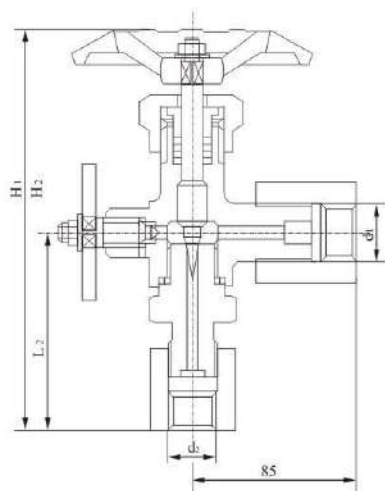

序号	公称通径	公称压力	连接尺寸		外形尺寸			
	DN	PN	d ₁	d ₂	L ₁	L ₂	H ₁	H ₂
1	3	32	M20 × 1.5	M14 × 1.5	58	68	95	88
2	3	32	M20 × 1.5	M20 × 1.5	58	68	95	88

TKJ-10B J49 型压力计用截止阀
TKJ-10B J49 Pressure Gauge Stop Valve

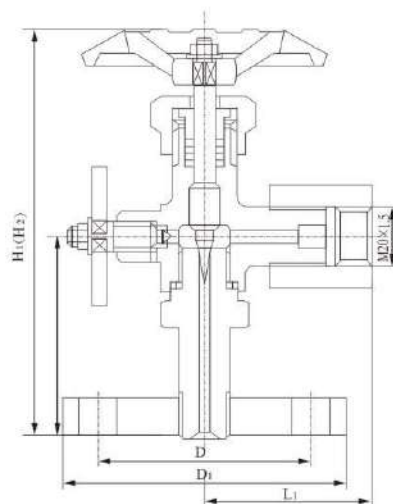

序号	公称通径	公称压力	外形尺寸和连接尺寸					
	DN	PN(MPa)	L ₁	D	D ₁		H ₁	H ₂
1	3	32	58	42	70		95	88

TKJ-11A J41 型法兰截止阀
TKJ-11A J41 Flange-type stop Valve

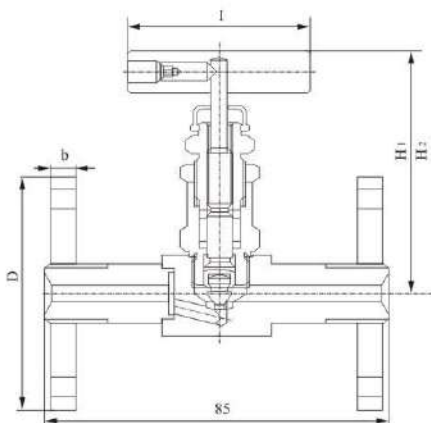

序号	公称通径 DN	公称压力 PN(MPa)	L	D	I	b	H ₁	H ₂
1	3	32	120	70	76	15	99	93
2	6	32	120	70	76	15	99	93
3	10	32	180	95	76	20	101	87
4	15	32	210	105	100	20	158	143

TKJ-11A J44 型法兰截止阀
TKJ-11A J44 Flange-type stop Valve

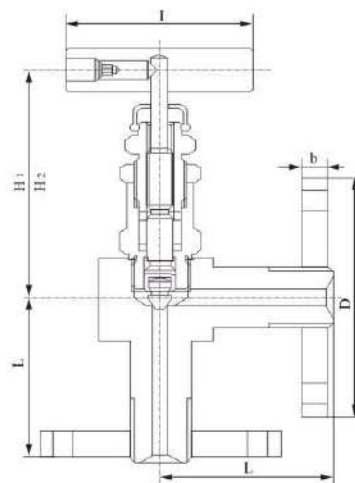

序号	公称通径 DN	公称压力 PN(MPa)	L	D	b	I	H ₁	H ₂
1	3	32	60	70	15	76	99	93
2	6	32	60	70	15	76	99	93
3	10	32	90	95	20	76	101	87
4	15	32	105	105	20	100	158	143

TKJ-12A J61^H 系列高温高压焊接截止阀

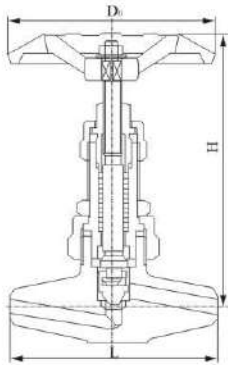
 TKJ-12A J61^H Series High Temperature and Pressure Welded Stop Valve

型号 Model	工作压力 Working pressure	公称 通径 DN	公称 压力 PN	主要结构尺寸 Overall size			适用温度℃ Suitable temp(≤)
				L	H	D ₀	
J61H-320C		10	320	100	162	100	450
J61H-320C		20	320	118	208	130	450
J61H-200C		10	200	100	148	100	450
J61H-200C		15	200	108	175	130	450
J61H-200C		20	200	118	185	130	450
J61Y-P ₅₄ 140V	140	10		100	162	130	540
J61Y-P ₅₄ 140V	140	15		108	195	130	540
J61Y-P ₅₄ 140V	140	20		118	208	160	540
J61Y-P ₅₆ 170V	170	10		100	162	130	560
J61Y-P ₅₆ 170V	170	15		108	195	130	560
J61Y-P ₅₆ 170V	170	20		118	208	160	560

TKJ-12B J41H 系列高温高压法兰截止阀

TKJ-12B J41H Series Flange High Temperature and Pressure Stop Valve

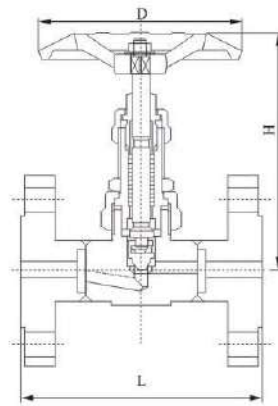

型号 Model	工作压力 Working pressure	公称压力 PN (Mpa)	主要结构尺寸 Overall size		
			L	D	H
J41H-64P	10	6.4	170	100	159
J41H-64P	15	6.4	170	105	165
J41H-64P	20	6.4	190	125	195
J41H-160P	10	16	170	110	165
J41H-160P	15	16	170	110	195
J41H-160P	20	16	190	130	165
J41H-100C	10	10	170	110	195
J41H-100C	15	10	170	110	165
J41H-100C	20	10	190	130	195

TKJ-12C J61Y 系列高温高压焊接截止阀

TKJ-12C J61Y Series High Temperature and Pressure Welded Stop Valve

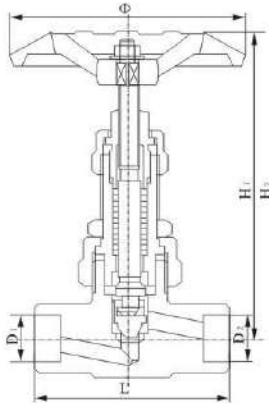

型号 Model	公称 通径 DN	公称 压力 PN	适用温度℃ Suitable temp(≤)	主要结构尺寸 Overall size						制造材料 Material
				L	Φ	H ₁	H ₂	D ₁	D ₂	
FJ61Y ₅₄ 170P	6	17	560	78	126	174	162	Φ10	Φ8	1Cr18Ni9Ti 316L 304L
FJ61Y ₅₄ 320P	6	32	560	78	126	178	165	Φ10	Φ10	
FJ61Y ₅₄ 170P	10	17	560	78	130	185	173	Φ16	Φ14	12CrMoV 密封面堆 焊钴基硬 质合金
FJ61Y ₅₄ 320P	10	32	560	78	180	192	192	Φ16	Φ16	
FJ61Y ₅₄ 170P	15	17	560	78	180	245	230	Φ28	Φ22	
FJ61Y ₅₄ 320P	15	32	560	78	180	255	240	Φ28	Φ28	

TKJ-12D FJ21Y 系列高温高压焊接截止阀

TKJ-12D FJ21Y Series High Temperature and Pressure Welded Stop Valve

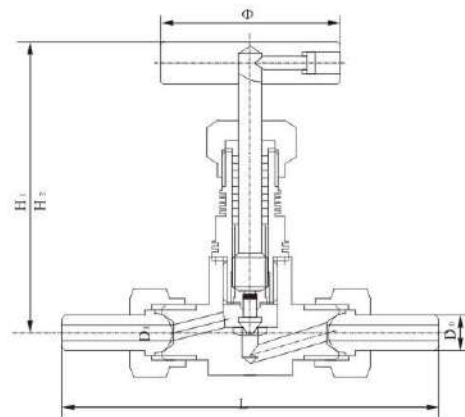

型号 Model	公称 通径 DN	公称 压力 PN	适用温度℃ Suitable temp(≤)	主要结构尺寸 Overall size					制造材料 Material
				L	Φ	H ₁	H ₂	D ₀	
FJ21Y ₅₄ 160P	6	16	560	146	70	125	115	Φ14	1Cr18Ni9Ti 316L 304L 12CrMoV 密封面堆 焊钴基硬 质合金
FJ21Y ₅₄ 160P	10	16	560	146	70	125	115	Φ18	
FJ21Y ₅₄ 320P	6	32	560	156	80	125	115	Φ14	
FJ21Y ₅₄ 320P	10	32	560	156	80	125	115	Φ18	

TKJ12-15 S19 H-1 型热动力式疏水器
TKJ12-15 S19 H-1 Heat Power Water Dredging Valve

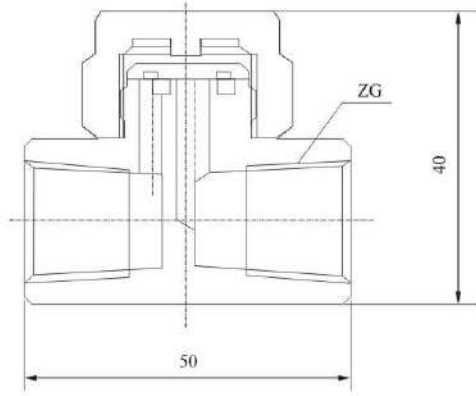

序号	公称压力PN	公称通径DN	ZG
1	2MPa	10	ZG1/4"
2		15	ZG1/2"

TKJ12-19 J26^W_H 型三通截止阀
TKJ12-19 J26^W_H 3-way Stop Valve

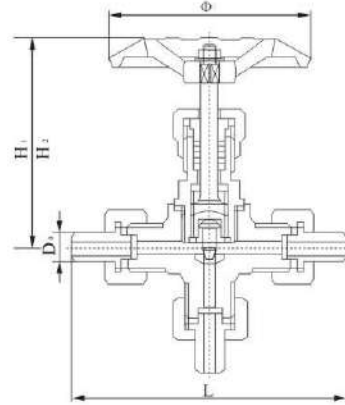

序号	公称通径DN	公称压力PN(MPa)	配管外径D ₀	外形尺寸				制造材料
				L	Φ	H ₁	H ₂	
1	3	6.4	Φ 14	118	62	91	85	20# 1Cr18Ni9Ti 0Cr18Ni12 Mo2Ti 304L 316L
2		16		126	68	96	90	
3		32		134	75	103	96	
4	5	6.4	Φ 14	120	62	93	87	
5		16		128	68	98	92	
6		32		136	75	105	98	
7	10	6.4	Φ 18	132	75	103	95	
8		16		136	75	108	100	
9		32		144	75	114	106	
10	15	2.5	Φ 22	160	75	123	112	
11		6.4		168	86	126	116	
12		16		174	126	132	120	

TK12-33 J93H 微型直通截止阀
TK12-33 J93H Miniature straight way stop vavle

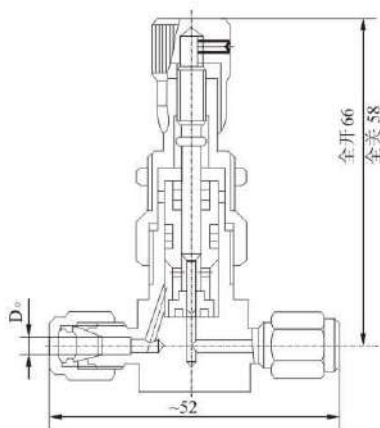

公称压力PN16MPa
 配管D₀: Φ3、Φ6

TK12-34 J94H 微型角式截止阀
TK12-34 J94H Miniature angle patten stop valve

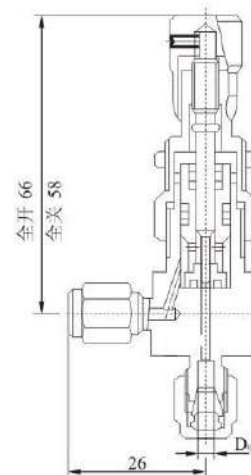

公称压力PN16MPa
 配管D₀: Φ3、Φ6

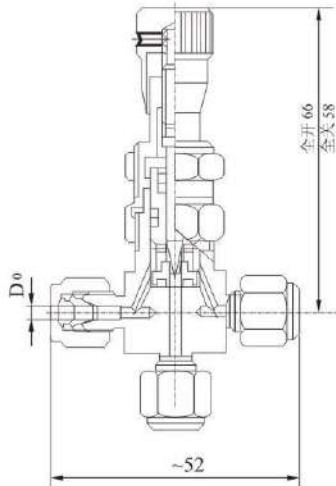
TK12-35 J99H 微型三通截止阀
TK12-35 J99H Miniature 3-way stop valve

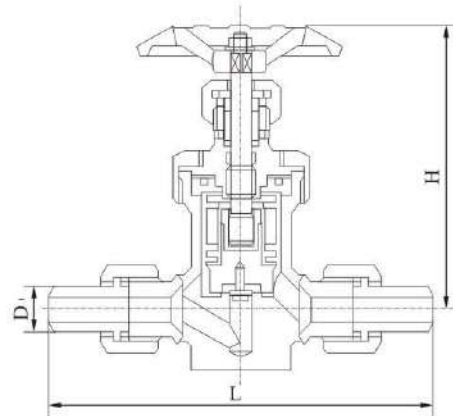
 公称压力PN16MPa
 配管D₀: Φ3、Φ6

TK21 波纹管截止阀
TK21 Bow pipe stop valve

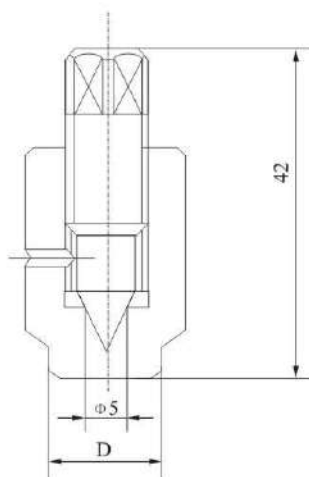
序号 NO.	公称压力 PN	公称通径 DN	L	H	D ₁
1	1.6	10	150	110	18
2	1.6	15	170	125	22
3	4.0	10	160	137	18
4	4.0	15	180	137	22

TK10-4 排气阀
TK10-4 Exhaust valve

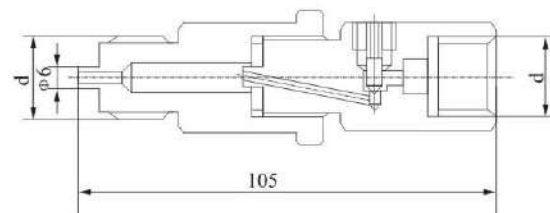
D: Φ14、Φ18

TK10-10 L21X-160 阻尼阀
TK10-10 L21X-160 Damping valve

序号 NO.	公称压力 PN(MPa)	公称通径 DN	d
1	16	3	M20 × 1.5
2	16	3	G1/2"

TKQ 系列测量管路球阀

TKQ Ball valve for measure pipeling

TK9-1 QG.Y1 型卡套式球阀
TK9-1 QG.Y1 Collet-type Ball Valve

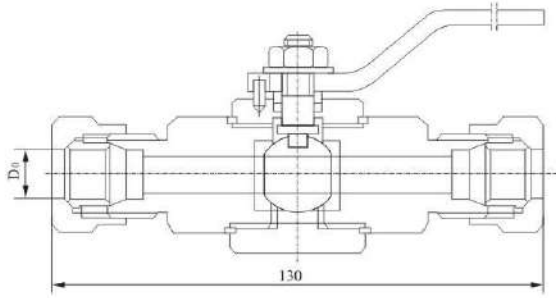

序号 NO	型号 Model	公称压力 PN	公称通径 DN	配管外径 D ₀
1	QG.Y1-1	2.5MPa	10	Φ12
2				Φ14

TK9-2 QG.AY1 型取压球阀
TK9-2 QG.AY1 Pressure-taking Ball Valve

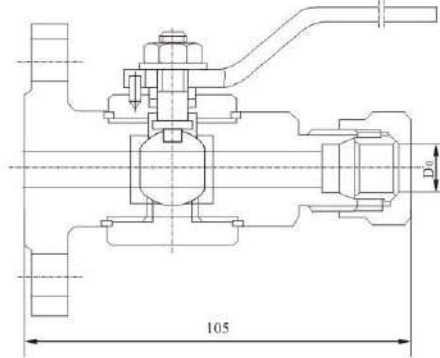

序号 NO	型号 Model	公称压力 PN	公称通径 DN	配管外径 D ₀
1	QG.AY1	2.5MPa	10	Φ12
2				Φ14

TK9-3 QG.M1 型压力表球阀
TK9-3 QG.M1 Pressure Gauge Ball Valve

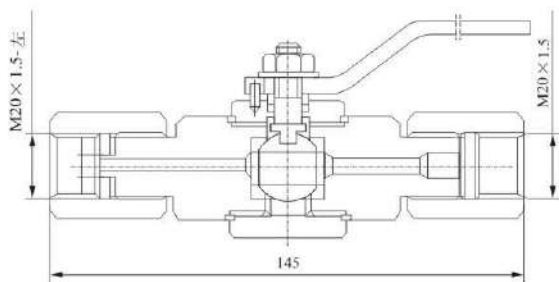

序号 NO	型号 Model	公称压力PN	公称通径DN
1	QG.M1	2.5MPa	3

TK9-4 QG.QY1 型气源球阀
TK9-4 QG.QY1 Gas Supply Ball Valve

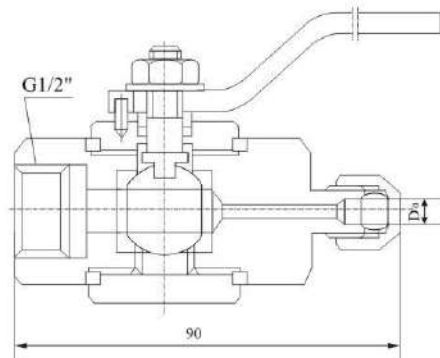

序号 NO	型号 Model	公称压力PN	公称通径DN	配管 D ₀
1	QG.GY1	1.0MPa	4	Φ6
2			6	Φ8

TK 12-23 QY-1型气动管路球阀
TK 12-23 QY-1 Pneumatic Tuke Ball Valve

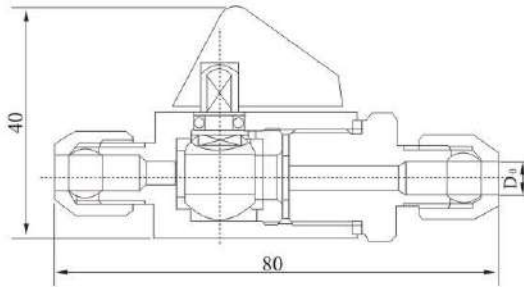

主体材料	T62
公称压力	PN 1.0MPa
配管 Do	Φ6、Φ8、Φ10
终端螺纹d	

TK 12-24 QY-2型气动管路球阀
TK 12-24 QY-2 Pneumatic Tuke Ball Valve

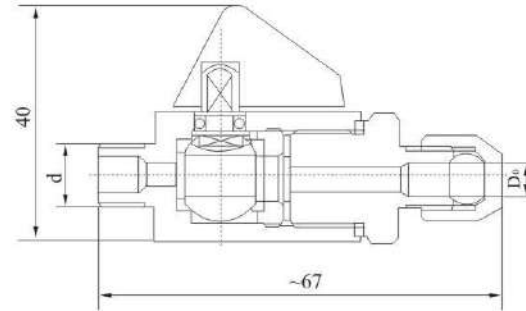

主体材料	T62
公称压力	DN 1.0MPa
配管 Do	Φ6、Φ8、Φ10
终端螺纹d	M10×1 ZG1/8"、ZG1/4"、G1/4"

TK 12-25 QY-3型气动管路球阀
TK 12-25 QY-3 Pneumatic Tuke Ball Valve

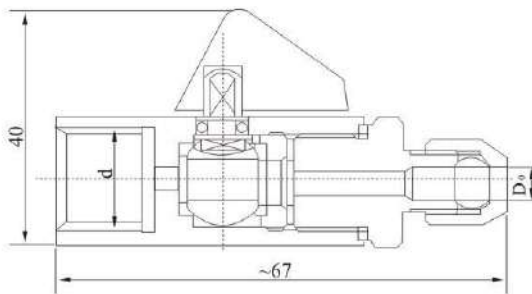

主体材料	T62
公称压力	PN 1.0MPa
配管 Do	Φ6、Φ8、Φ10
终端螺纹d	M10×1 G1/4"、ZG1/4"、ZG1/8"

TK 12-26 QH.Y1 QJ.Y1 型卡套式球阀
TK12-26 QH.Y1 QJ.Y1 Collet-type Ball Valve

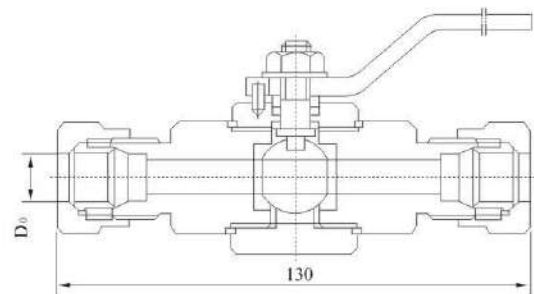

主体材料	20#、1Cr18Ni19Ti 316 316L
公称压力	PN ;4.0MPa、6.4MPa
公称通径DN	10、15
配管 Do	Φ12、Φ14、Φ18

TK12-27 Q11SA 型内螺纹球阀
TK12-27 Q11SA Female Serew Ball Valve

序号 No	型号 Model	公称压力 PN	公称口径 DN
1	Q11SA-64 C P	6.4MPa	10
2			15
3			20
4			25

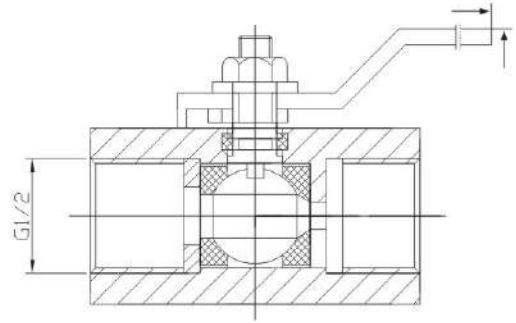

TKQ-1A Q81SA-64 型卡箍式球阀
TKQ-1A Q81SA-64 Taggle Ball Valve

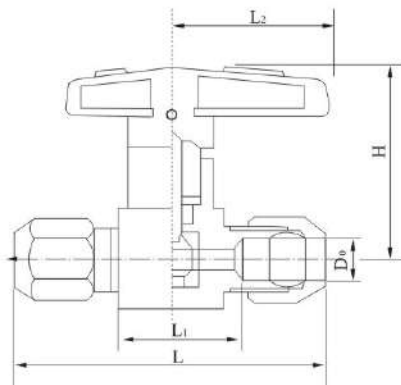

序号	公称压力 PN	公称口径 DN	配管外径 D ₀	外型尺寸				制造材料
				L	L ₁	L ₂	H	
1	6.4 MPa	4	6	58	28	30	32	20 1Cr18Ni9Ti 0Cr18Ni12 Mo2Ti 304L 316L
2		6	8	62	28	30	42	
3		8	10	78	36	38	50	

TKQ-1B Q²/₈ SA-64 型终端卡箍式球阀
TKQ-1B Q²/₈ SA-64 Toggle Ball Valve

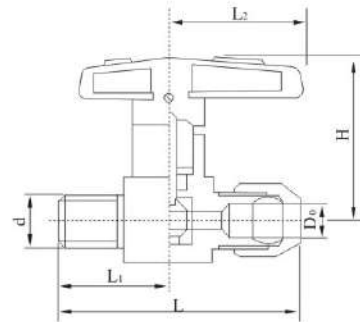

序号 No	公称压力 PN	公称口径 DN	配管外径 Pipe size		外型尺寸 Overall Size				适用温度(°C) Suitable temp
			d	D ₀	L	L ₁	H ₁	H ₂	
1	6.4 MPa	4	M10 × 1	6	48	19	30	32	常温 Normal Temp
2			ZG1/8"		48	19			
3			ZG1/4"		50	21			
4			G1/4"		50	21			
5		6	M10 × 1	8	52	21	30	42	
6			ZG1/8"		52	21			
7			ZG1/4"		54	23			
8			G1/4"		54	23			
9		8	M10 × 1	10	58	24	38	50	
10			ZG1/8"		58	24			
11			ZG1/4"		60	26			
12			G1/4"		60	26			

TKQ-1C Q¹/₈ SA-64 型卡箍式球阀
TKQ-1C Q¹/₈ SA-64 Taggle Fype Ball

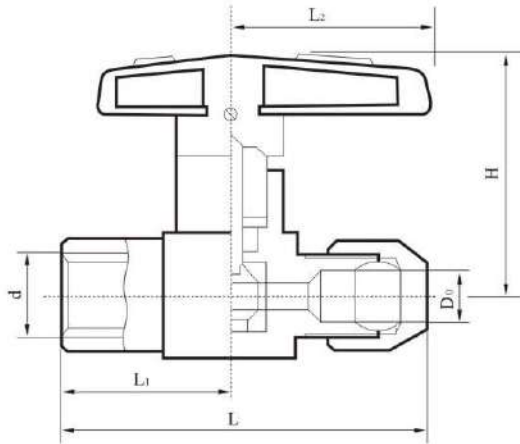

序号 No	公称压力 PN	公称口径 DN	配管尺寸 d D ₀	外型尺寸				适用温度(°C) Suitable temp
1	6.4 MPa	4	M10×1	48	19	30	32	常温 Normal Temp
2			ZG1/8"	48	19			
3			ZG1/4"	50	21			
4			G1/4"	50	21			
5		6	M10×1	52	21	30	42	
6			ZG1/8"	52	21			
7			ZG1/4"	54	23			
8			G1/4"	54	23			
9		8	M10×1	58	24	38	50	
10			ZG1/8"	58	24			
11			ZG1/4"	60	26			
12			G1/4"	60	26			

TKQ-2A Q11SA-64 型内螺纹球阀
TKQ-2A Q11SA-64 Female Screw Ball Valve

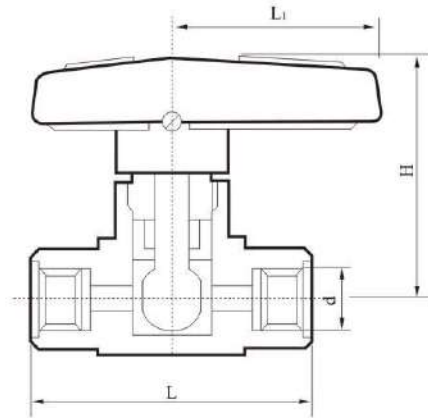

序号 No	公称压力 PN	公称口径 DN	配管螺纹 d	外型尺寸			适用温度(°C) Suitable temp
1	6.4 MPa	4	M10×1	40	30	32	常温 Normal Temp Norm
2			ZG1/8"				
3			G1/8"				
4			ZG1/4"				
5		6	G1/4"	50	38	42	
6			M16×1.5				
7			ZG3/8"				
8		8	G3/8"	60	45	50	
9			M20×1.5				
10			ZG1/2"				
11			G1/2"				

TKQ-2B Q11SA-64 型内螺纹球阀
TKQ-2B Q11SA-64 Female Screw Ball Valve

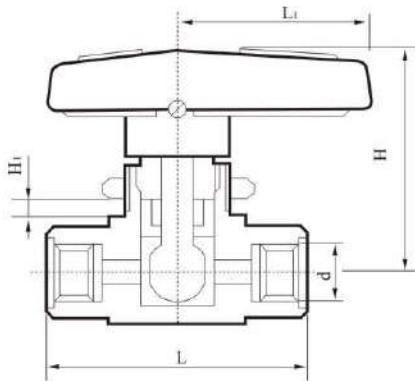

序号 No	公称压力 PN	公称口径 DN	配管螺纹 d	外型尺寸				适用温度(°C) Suitable temp
1	6.4 MPa	4	M10×1	40	30	32	4	常温 Normal Temp Norm
2			ZG1/8"					
3			G1/8"					
4			ZG1/4"					
5		6	G1/4"	50	38	42	4	
6			M16×1.5					
7			ZG3/8"					
8		8	G3/8"	60	45	50	6	
9			M20×1.5					
10			ZG1/2"					
11			ZG1/2"					

TKQ-2C Q11F-64 型内螺纹球阀
TKQ-2C Q11F-64 Female Screw Ball Valve

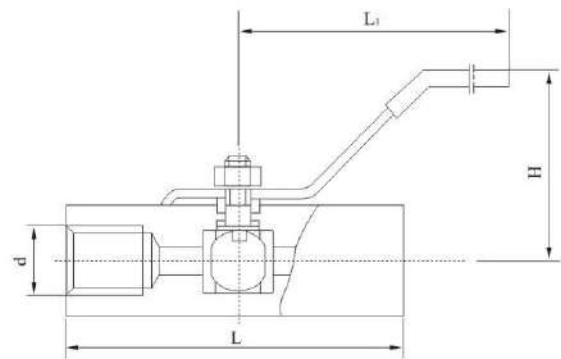

序号 No	公称压力 PN	公称口径 DN	实际口径 Pipe thread	配管螺纹 Union bonnet	管道连接螺纹	外型尺寸			适用温度(°C) Suitable temp
1	6.4 MPa	10	7.5	G3/8"	G3/8"	58	100	45	常温 Normal Temp
2		15	9.5	G1/2"	G1/2"	70	110	50	
3		20	12.5	G3/4"	G3/4"	80	120	52	
4		25	17	G1"	G1"	96	120	64	
5		32	23	G1 1/4"	G1 1/4"	100	130	70	
6		40	25	G1 1/2"	G1 1/2"	110	150	80	

TKQ-3 Q21F-64 型外螺纹球阀
TKQ-3 Q21F-64 Male Screw Ball Valve

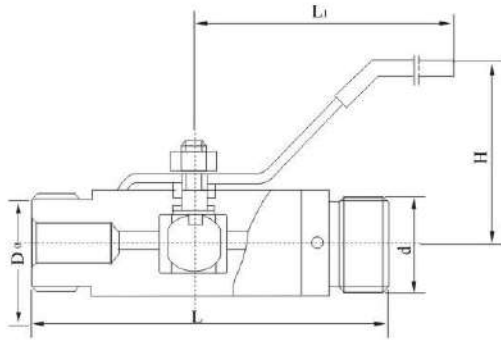

序号 No	公称 压力 PN	公称 口径 DN	实际 口径 DN	配管螺纹 d Pipe thread	配管 直径 D ₀	外型尺寸			适用温度(℃) Suitable temp
						L	L ₁	H	
1	6.4 MPa	10	7.5	M24×1.5	18	86	100	45	常温 Normal Temp
2		15	9.5	M30×2	22	90	110	50	
3		20	12.5	M36×2	28	110	120	52	
4		25	17	M42×2	34	130	120	64	

TKQ-4 Q91SA-64 型卡套球阀
TKQ-4 Q91SA-64 Collet Valve

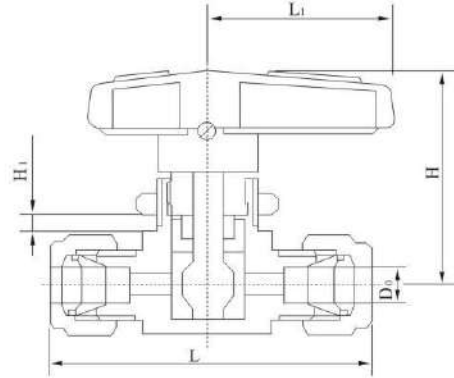

序号 No	公称 压力 PN	公称 口径 DN	配管 外径 D ₀	适用温度(℃) Suitable temp	外型尺寸			
					L	L ₁	H	H ₁
1	6.4 MPa	4	6	常温 Normal Temp	60	30	32	4
2		6	8		65	38	42	4
3		8	10		75	45	50	6
		8	12					
4	10	14	88	60	60	6		

TKQ-5A Q93SA-64 型双卡套角式球阀
TKQ-5A Q93SA-64 Double-Collet Angle Pattern Ball Valve

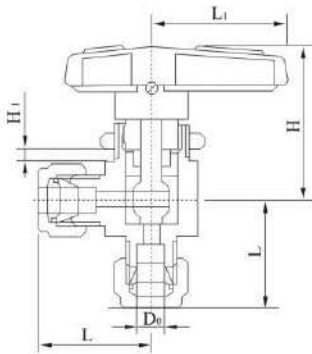

序号 No	公称 压力 PN	公称 口径 DN	配管 外径 D ₀	适用温度(℃) Suitable temp	外型尺寸 Overall Size			
					L	L ₁	H	H ₁
1	6.4 MPa	4	6	常温 Normal Temp	30	30	32	4
2		6	8		32	38	42	4
3		8	10		38	45	50	6
		8	12					
4	10	14	44	60	60	6		

TKQ-5B Q13SA-64 型内螺纹角式球阀
TKQ-5B Q13SA-64 Female Angle Pattern Ball Valve

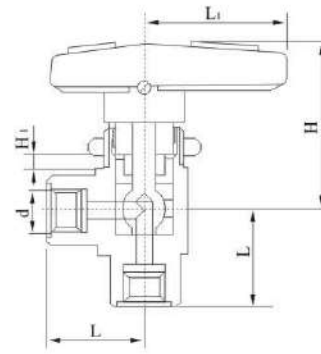

序号 No	公称 压力 PN	公称 口径 DN	配管螺纹 d	适用温度(℃) Suitable temp	外型尺寸			
					L	L ₁	H	H ₁
1	6.4 MPa	4	M10×1	常温 Normal Temp	20	20	32	4
2			ZG1/8"					
3			G1/8"					
4		6	ZG1/4"		25	38	42	4
5			G1/4"					
6			M16×1.5					
7		8	ZG3/8"		30	45	50	6
8			G3/8"					
9			M20×1.5					
10		10	ZG1/2"		32	60	60	6
11			G1/2"					

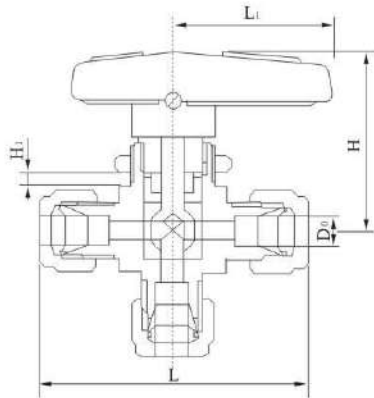
TKQ-6A Q94SA-64 型卡套三通球阀
TKQ-6A Q94SA-64 Collet 3-Way Ball Valve

序号 No	公称压力 PN	公称通径 DN	配管 外径 D ₀	适用温度 (°C) Suitable temp	外型尺寸 Overall Size			
					L	L ₁	H	H ₁
1	6.4 MPa	4	6	常温 (°C) Normal Temp	60	30	32	4
2		6	8		65	38	42	4
3		8	10		75	45	50	6
4		12	14		85	60	60	6

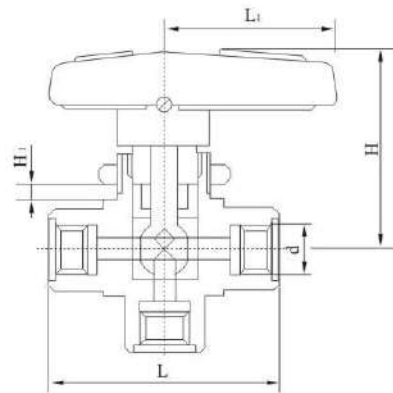
TKQ-6B Q14SA-64 型内螺纹三通球阀
TKQ-6B Q14SA-64 Femals Serew 3-Way Ball Valve

序号 No	公称压力 PN	公称通径 DN	配管外径 d	适用温度(°C) Suitable temp	外型尺寸			
					L	L ₁	H	H ₁
1	6.4 MPa	4	M10×1	常温 (°C) Normal Temp Norm	40	30	32	4
2			ZG1/8"					
3			G1/8"					
4		6	ZG1/4"		50	38	42	4
5			G1/4"					
6		8	M16×1.5		60	45	50	6
7			ZG3/8"					
8			G3/8"					
9		10	M20×1.5		65	60	60	6
10			ZG1/2"					
11			G1/2"					

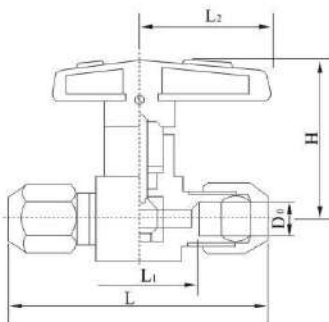
TKQ-7 PQ81SA-64 型排气球阀
TKQ-7 PQ81SA-64 Exhaurt Ball Valve

说明:

此阀为各系统仪表安装的专用产品, 阀门打开, 进气口与出气口接通, 排气口关闭, 当手轮旋转90°, 进气口与出气口切断, 出气口与排气口接通, 排出测量仪表气体。

Directions:

It is a special product of various gauge installations. while the valve opening, the admision is connected with the outlet and exhaust is closed when the handle is turned 90°, the admission and outlet are cut off but the outlet is connected with the exhaust and the gauge gas is exharter.

序号 No	公称压力 PN	公称通径 DN	配管 外径 D ₀	外型尺寸				适用温度(°C) Suitable temp
				L	L ₂	L ₁	H	
1	6.4 MPa	4	6	62	28	30	32	常温 (°C) Normal Temp
2		6	8	62	28	30	36	
3		8	10	66	36	38	40	

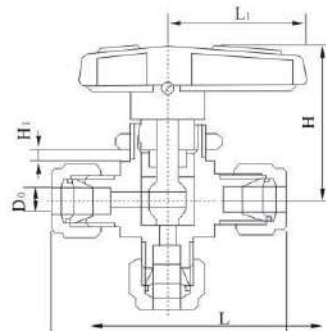
TKQ-8A YFP-1A 型两位一通双卡套球阀
TKQ-8A YFP-1A 2-Direction and 1-Way Double Collet Ball Valve

序号 No	公称压力 PN	公称通径 DN	配管 外径 D ₀	适用温度(°C) Suitable temp	外型尺寸 Overall Size			
					L	L ₁	H	H ₁
1	6.4 MPa	4	6	常温 (°C) Normal Temp	60	30	35	5
2		6	8		65	38	40	5
3		8	12		85	45	55	7
4		10	14		85	60	65	7

TKQ-8B YFP-1B 型两位一通内螺纹切换球阀
TKQ-8B YFP-1B 2-Direction and 1-way
Female cutting and changing Ball Valve

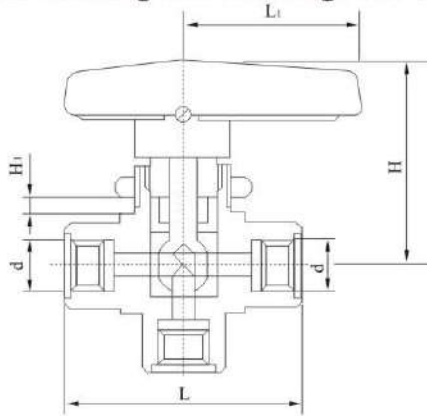

TKQ-9 YFP-2 型两位通切换球阀
TKQ-9 YFP-2 2-Direction and 1-way Female cutting
and changing Ball Valve

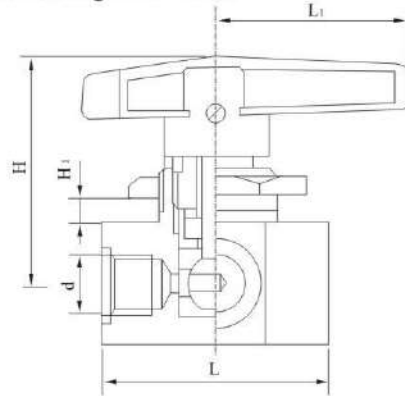

序号 No	公称压力 PN	公称口径 DN	配管螺纹 Pipe thread(d)	适用温度(°C) Suitable temp	外型尺寸			
					L	L1	H	H1
1	6.4 MPa	4	M10×1	常温 (°C) Normal temp	40	30	32	4
2			ZG1/8"					
3			G1/8"					
4		6	ZG1/4"		50	38	42	4
5		G1/4"						
6		8	M16×1.5		60	45	50	6
7		ZG3/8"						
8		G3/8"						
9		10	M20×1.5		65	60	60	6
10		ZG1/2"						
11		G1/2"						

注：1、如用户连接需塑料管或铜管式，请在订货时注明，我厂将配制相应的终端接头。
 2、本阀具有两个进气源接口，一般用于两股介质的同时切换。

Notes: 1. If the plastic or copper are needed for connexion, please give clear order, well provide relevant extreme joints.
 2. It has two admission connectors and is for the two whiffs of the medicom to be cut and changed at the same time.

序号 No	公称压力 PN	公称口径 DN	配管螺纹 Pipe thread(d)	适用温度 Suitable temp	外型尺寸			
					L	L1	H	H1
1	6.4 MPa	2.4	M10×1	常温 (°C) Normal Temp	50	45	55	5
2			ZG1/8"					
3			ZG1/4"					

TKQ-10 YFP-3 型四位一通切换球阀
TKQ-10 YFP-3 4-Direction and 1-way Cutting and Ball Valve

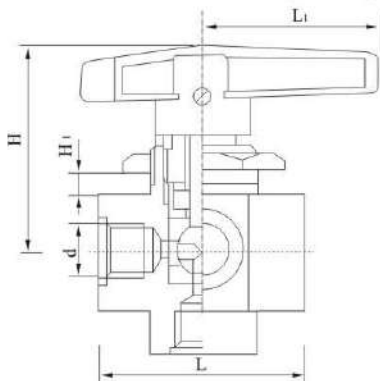

注：1.若此阀门需要与塑料管或铜管连接，请在订货时注明。
 2.本阀门一个进气源，分别向四个方位切换，亦可用于四股介质分别向一个方位切换。

Note: 1. If the plastic or copper pipes are needed for connexion, please give clear order.
 2. Its admission connector can cut and change towards four directions and can also make four whiffs of the medicom be cut and changed to one direction.

序号 No	公称压力 PN	公称口径 DN	配管螺纹 Pipescrew(d)	适用温度 (°C) Suitable temp	外型尺寸 Overall Size			
					L	L1	H	H1
1	6.4 MPa	2.4	M10×1	常温 Normal Temp	50	45	55	5
2			ZG1/8"					
3			ZG1/4"					

TKQ-11 YFP-4 型四位两通切换球阀
TKQ-11 YFP-4 4-Direction and 2-way Cutting and Changing Ball Valve

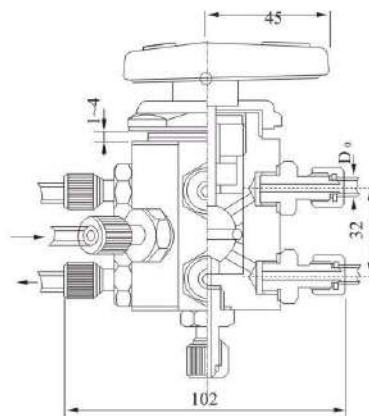

注：本阀门具有两个进气源，分别向四个方位切换，亦可用于八股介质分别向两个方位切换。

Note: It has two admission connectors and can cut and change towards four directions and can also make eight whiffs of the medium be cut and changed to two directions.

性能规范 Performance standard	公称压力：1MPa，公称口径：DN4 PN: 1MPa DN: DN4
适用介质 Suitable medicom	各种气体和非腐蚀介质 All kinds of gas and noncorrosive medium
配管尺寸 D ₀ Pipe size	配管 Φ6×1 塑料管或尼龙管 Pipe: plastic or nylon pipes of Φ6×1

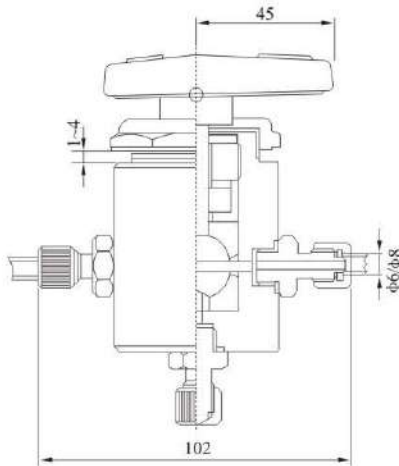
TKQ-12 YFP-5 型六位一通切换球阀
TKQ-12 YFP-5 Direction and 1-Way and Changing Ball valve

性能规范 Performance standard	公称压力: 1MPa, 公称通径: DN4 PN: 1MPa DN:DN4
适用介质 Suitable medium	各种气体和非腐蚀介质 All kinds of gas and noncorrosive medium
配管尺寸 D ₀ Pipe size	配管 Φ6×1 塑料管或尼龙管 Pipe: plastic or nylon pipes of Φ6×1

注: 本阀有一个进气源, 分别向六个方位切换。亦可用于六个方向一个出口切换

Note: The valve has one admission connector and change to wards six directions or six directions to wards one outlet.

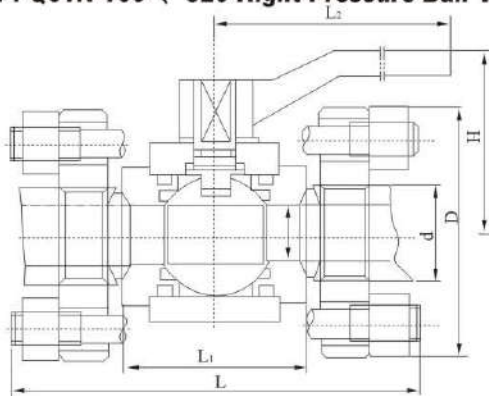
TKQ-14 Q61N-160、320 型高压球阀
TKQ-14 Q61N-160、320 High Pressure Ball Valve

序号 No	公称压力 PN	公称通径 DN	外型尺寸					适用温度 (°C) Suitable temp
			L	L ₁	L ₂	D	D ₁	
1	16 32 MPa	10	150	60	160	90	10	-40°C-50°C
2		15	170	70	160	100	23	
3		20	190	81	250	110	29	
4		25	205	95	250	115	36	
5		32	230	110	350	150	43	
6		40	260	120	450	170	49	
7		50	330		450	200	61	

注: 本阀可制成对焊式, 承插焊式等多种联接形式

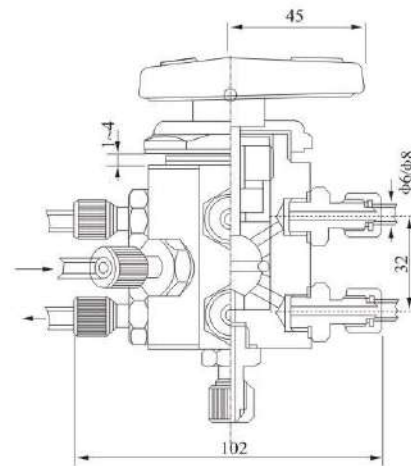
TKQ-13 YFP-6 型六位两通切球阀
TKQ-13 YFP-6 Direction and 1-Way cutting and Changing Ball valve

性能规范 Performance standard	公称压力: 1MPa, 公称通径: DN4 PN: 1MPa DN:DN4
适用介质 Suitable medium	各种气体和非腐蚀介质 All kinds of gas and noncorrosive medium
配管尺寸 D ₀ Pipe size	配管 Φ6×1 塑料管或尼龙管 Pipe: plastic or nylon pipes of Φ6×1

注: 本阀具有两个进气源分别向六个方位切换; 亦可用12个方位分别向两个方向切换

Note: The valve has two admission connectors and can cut and change towards six directions or twelve directions to two directions

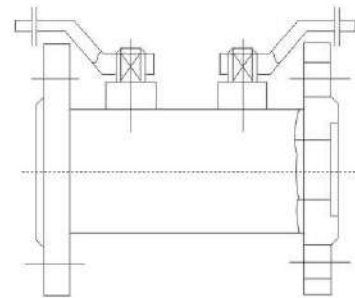
TKQ-15 Q41F 双联球阀
TKQ-15 Q41F Double Union Ball Valve

公称压力 PN	公称通径 DN	适用温度(°C) Suitable temp
1.6 2.5 MPa 4.0	15	-20°C-150°C
	20	
	25	
	32	
	40	
	50	
	65	
	80	
	100	

TK 仪表系列阀组 TK Gauge Series Valves

TKEF-1型二阀组 TKEF-1 Two Series Vale

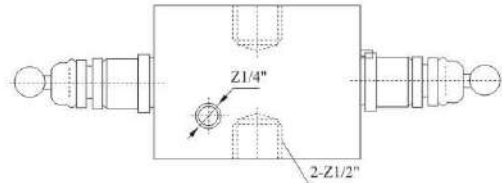
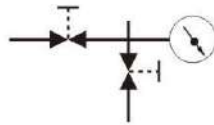

序号	公称压力PN	公称口径DN	适用温度 °C	阀体材料
1	20MPa	5	-20~440	35#
2	20MPa	5	-70~240	1Cr18Ni9Ti
3	40MPa	5	-20~440	35#
4	40MPa	5	-70~240	1Cr18Ni9Ti

这种阀组将切断、校准、和排气三种装置集于一体，结构小巧，减少了易漏接头。该阀有两个凹形接头，可供压力计、压力传感器或压力开关安装使用。接头螺纹可根据用户需要为 PT、PF、NPT、G、ZG、R等，请在订货时注明。

This valve makes cutting, calibrating and exhausting as one, has the simple structure, reduces the easily leaking connectors. It has two sunken connectors for the installation of the manometer, pressure transducer or pressure switch. The union bonners can be chosen to wire from the standards of PT, PF, NPT, G, ZG, R, etc, Please give a definite order.

TKEF-2 型二阀组 TKEF-2 Two series Vale

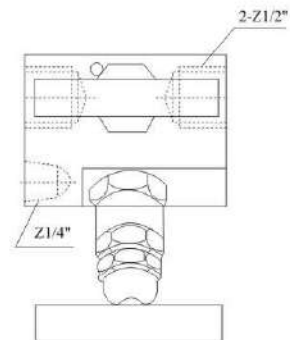
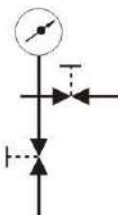

序号	公称压力PN	公称口径DN	适用温度 °C	阀体材料
1	20MPa	5	-20~440	35#
2	20MPa	5	-70~240	1Cr18Ni9Ti
3	40MPa	5	-20~440	35#
4	40MPa	5	-70~240	1Cr18Ni9Ti

这种阀组将切断、校准、和排气三种装置集于一体，结构小巧，减少了易漏接头。该阀组有两个凹形接头，可供压力计、压力传感器或压力开关安装使用。接头螺纹可根据用户需要在为PT、PF、NPT、G、ZG、R等，请在订货时注明。

This valve makes cutting, calibrating and exhausting as one, has the simple structure, reduces the easily leaking connectors. It has two sunken connectors for the installation of the manometer, pressure transducer or pressure switch. The union bonners can be chosen to wire from the standards of PT, PF, NPT, G, ZG, R, etc, Please give a definite order.

TKEF-3 型二阀组 TKEF-3 Two series Vale

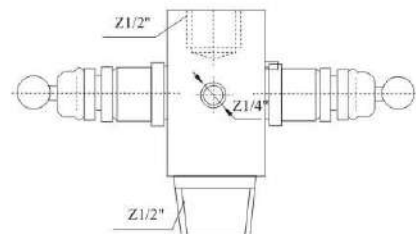
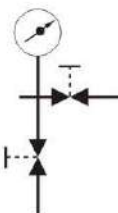

序号	公称压力PN	公称口径DN	适用温度 °C	阀体材料
1	20MPa	5	-20~440	35#
2	20MPa	5	-70~240	1Cr18Ni9Ti
3	40MPa	5	-20~440	35#
4	40MPa	5	-70~240	1Cr18Ni9Ti

这种阀组将切断、校准、和排气三种装置集于一体，结构小巧，减少了易漏接头。该阀有一对凹形凸形接头，可供压力计、压力传感器或压力开关安装使用。接头螺纹可根据用户需要在为PT、PF、NPT、G、ZG、R等，请在订货时注明。

This valve makes cutting, calibrating and exhausting as one, has the simple structure, reduces the easily leaking connectors. It has two sunken connectors for the installation of the manometer, pressure transducer or pressure switch. The union bonners can be chosen to wire from the standards of PT, PF, NPT, G, ZG, R, etc, Please give a definite order.

TKEF1151 型二阀组
TKEF1151 Two series Valve



序号	公称压力PN	公称通径DN	适用温度℃	阀体材料
1	20MPa	5	-20~440	35#
2	20MPa	5	-70~240	1Cr18Ni9Ti
3	40MPa	5	-20~440	35#
4	40MPa	5	-70~240	1Cr18Ni9Ti

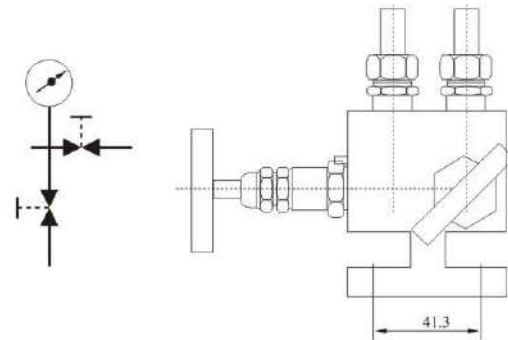

该阀组将切断、校准和排气三种装置集于一体，通过法兰可与变送器直接连接，结构小巧，利于安装。

This valve makes cutting, calibrating and exhausting as one, has the simple structure, reduces the easily leaking connectors.

TKEF-4 内螺纹二阀组
TKEF-4 Two series Valve



序号	公称压力PN	公称通径DN	适用温度℃	阀体材料
1	20MPa	5	-20~440	35#
2	20MPa	5	-70~240	1Cr18Ni9Ti
3	40MPa	5	-20~440	35#
4	40MPa	5	-70~240	1Cr18Ni9Ti

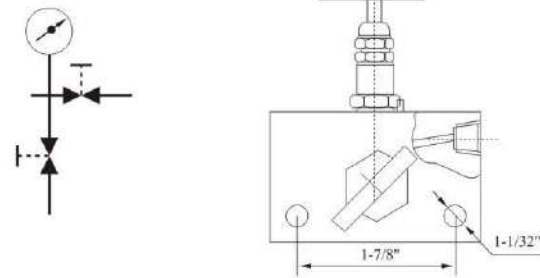

该阀组是在借鉴新加坡阀组的基础上改进的，其结构小巧灵活，通过安装孔把阀组和变送器固定在支架上，解决了现场仪表一体化装置中无法固定阀组的难题。

This valve makes cutting, calibrating and exhausting as one, has the simple structure, reduces the easily leaking connectors.

TKEF-T1 体化二阀组
TKEF-T1 integralization two series valve



序号	公称压力PN	公称通径DN	配管外径	适用温度℃	材料
1	32	5	Φ14	-20~440	35#
2	32	5	Φ14	-70~240	1Cr18Ni9Ti

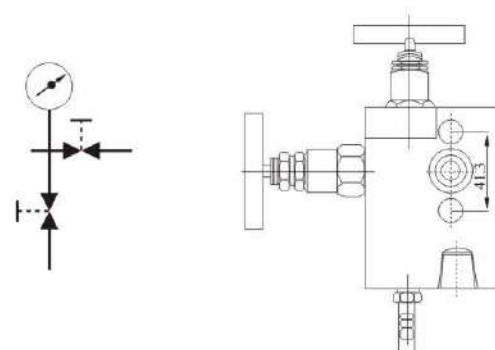

该阀将切断，校准和排气三种装置集于一体，结构小巧，可直接固定在变送器上，减少了易漏接头。

This valve integrates the three devices of cutting, gauging, and exhaustion into one body; its structure is compact and it can be directly fixed on the transmitter to reduce free-leaking connectors.

TKSF-1151 三阀组
TKSF-1151 Three Series Valves

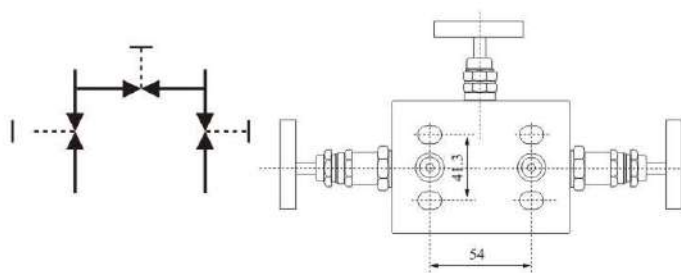

序号	公称压力PN	公称通径DN	适用温度℃	阀体材料
1	20MPa	5	-20~440	35#
2	20MPa	5	-70~240	1Cr18Ni9Ti
3	40MPa	5	-20~440	35#
4	40MPa	5	-70~240	1Cr18Ni9Ti

该阀组与1151系列电容差压变送器配套安装，用于从引压点将信号引入1151系列差压力变送器正、负测量室，使引压点与测量室接通或断开。通过法兰与变送器直接连接。

This valve group can be directly fixed on the transmitter and used in leading the signals to the positive and negative measuring chambers of differential pressure transmitter from the point for measuring pressure to make the leading point for pressure connect with or cut off the measuring chambers.

TKSF-T1 一体化三阀组
TKSF-T1 Integralization Three Series Valves

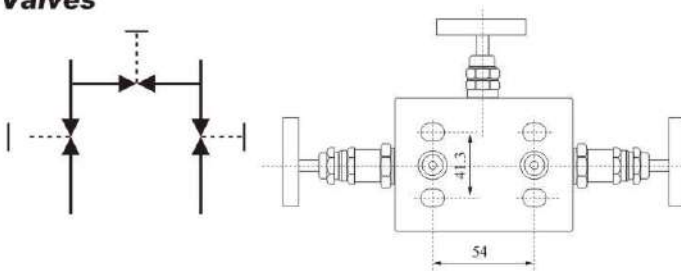

序号	公称压力PN	公称通径DN	适用温度℃	阀体材料
HYYSF-1	20MPa	5	-20~440	35#
HYYSF-2	20MPa	5	-70~240	1Cr18Ni9Ti

该阀组可直接固定在变送器上，用于从引压点将信号引入差压变送器正、负测量室，使引压点与测量室接通或断开。

This valve group can be directly fixed on the transmitter and used in leading the signals to the positive and negative measuring chambers of differential pressure transmitter from the point for measuring pressure to make the leading point for pressure connect with or cut off the measuring chambers.

TKSF-FL 法兰三阀组
TKSF-FL Three Series Valves

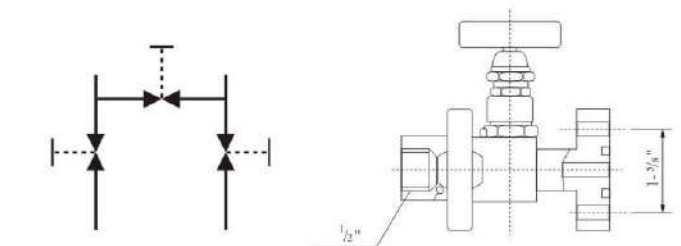

序号	公称压力PN	公称通径DN	适用温度℃	阀体材料
1	20MPa	5	-20~440	35#
2	20MPa	5	-70~240	1Cr18Ni9Ti
3	40MPa	5	-20~440	35#
4	40MPa	5	-70~240	1Cr18Ni9Ti

该阀组由高、低压阀及平衡阀组成一体，其作用与QFF3相同，引压点连接方式采用套式或焊接式，而与变送器则通过法兰直接相连，减少了易漏点，利于安装。

This valve group can be directly fixed on the transmitter and used in leading the signals to the positive and negative measuring chambers of differential pressure transmitter from the point for measuring pressure to make the leading point for pressure connect with or cut off the measuring chambers.

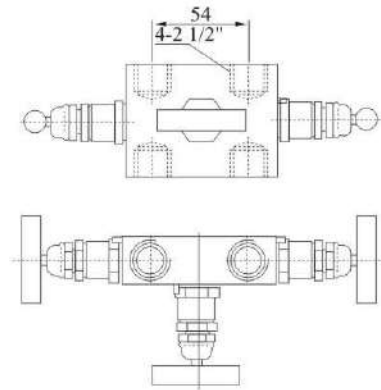
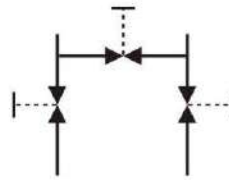
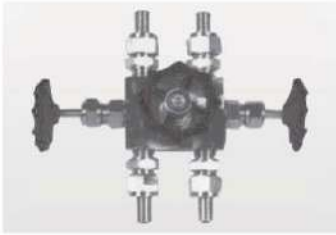
TKSF-1 型三阀组
TKSF-1 Three Series Valves

序号	公称压力PN	公称通径DN	适用温度 °C	阀体材料
1	20MPa	5	-20~440	35#
2	20MPa	5	-70~240	1Cr18Ni9Ti
3	40MPa	5	-20~440	35#
4	40MPa	5	-70~240	1Cr18Ni9Ti

该阀可安装在当流量测仪表需远传的脉动管道上,由两个取压阀和一个平衡阀组成,方便建立仪表控制回路。

This valve is formed from tow pressure taking valves and an equalizer , can be fixed in the pulsion tubing of the flow metering gauge thatis required toconey far away.It's conv enient to establish the gauge control return.

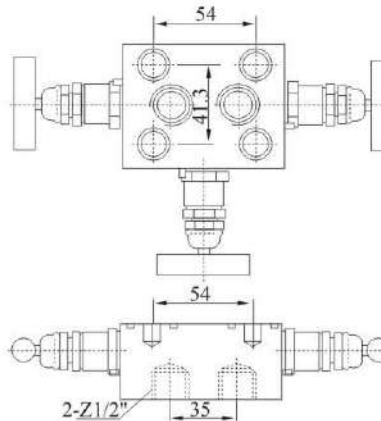
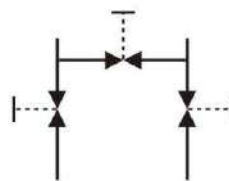
TKSF-2 型三阀组
TKSF-2 Three Series Valves

序号	公称压力PN	公称通径DN	适用温度 °C	阀体材料
1	20MPa	5	-20~440	35#
2	20MPa	5	-70~240	1Cr18Ni9Ti
3	40MPa	5	-20~440	35#
4	40MPa	5	-70~240	1Cr18Ni9Ti

该阀组可直接与差压、压力仪表或变送器配套安装使用,差压口亦可直接与导压管接头相连,两接头之间的中心距为35mm。

It can be linked divectly with the differential pressure gauge,pressure gauge or trans former.The differential pressure mouth can also be connected with the leading pressure pip joint and the center distance between the two joints is 35mm.

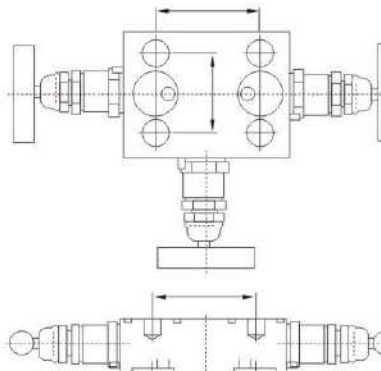
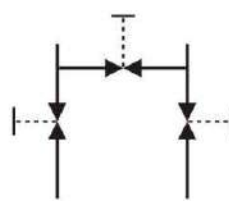
TKSF-3 型三阀组
TKSF-3 Three Series Valves

序号	公称压力PN	公称通径DN	适用温度 °C	阀体材料
1	20MPa	5	-20~440	35#
2	20MPa	5	-70~240	1Cr18Ni9Ti
3	40MPa	5	-20~440	35#
4	40MPa	5	-70~240	1Cr18Ni9Ti

该阀组可直接与差压、压力仪表或变送器配套安装使用,差压口通过腰形法兰与导压管接头相连接,两接头之间的中心差距为54mm。

It can divectlybe linked with the differential pressure, ressure, gauge or trans former.The pressure taking nouth is connected lwith the leading pressure pipe joint through the waist-like cange and the center distance between the two joints is 54mm.

TKSF-4 内螺纹三阀组
TKSF-4 Three Series Valves

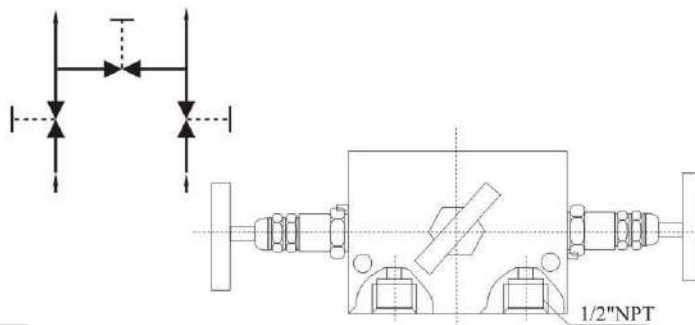

序号	公称压力PN	公称通径DN	适用温度℃	阀体材料
1	20MPa	5	-20~440	35#
2	20MPa	5	-70~240	1Cr18Ni9Ti
3	40MPa	5	-20~440	35#
4	40MPa	5	-70~240	1Cr18Ni9Ti

该阀组是参照新加坡的三阀组自行设计的,其结构紧凑,密封性能好,安装使用方便,阀组自带调装孔,可直接固定在安装支架上利于拆装。

The stop valve for measuring pipe line was designed by ourself based on taking the structures & forms england, the singapore and other countries. It is a valve of the new generation which is most universal used at present.

TKQFF3 型三阀组
TKQFF3 Three Series Valves

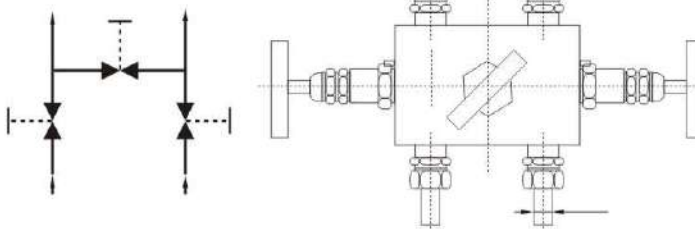

序号	公称压力PN	公称通径DN	适用温度℃	阀体材料
1	20MPa	5	-20~440	35#
2	20MPa	5	-70~240	1Cr18Ni9Ti
3	40MPa	5	-20~440	35#
4	40MPa	5	-70~240	1Cr18Ni9Ti

QFF3 型三阀组由高、低压阀及平衡阀组成一体,与差压变送器配套使用。其作用是将差压变送器正、负测量室与引压点导通或断开,或将正负压测量室断开和导通。引压、输压点直接与钢管连接,连接采用焊接,也可采用其它连接方式,订货时请注明。

It is formed from the high and low pressure valves and the equalizer valve and linked with the differential pressure transformer. It can connect or cut off between the \pm metering rooms of the differential transformer and the pressure drawing point for between the \pm pressure metering rooms. Pressure drawing or conveying point is directly connected with the steel pipe by welding. If you other connecting ways please give a clear indication on goods-ordering.

TKWF-1 型五阀组
TKWF-1 Five Series Valves

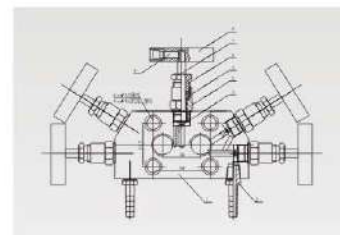
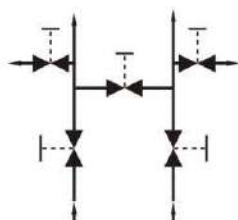

序号	公称压力PN	公称通径DN	适用温度℃	阀体材料
1	20MPa	5	-20~440	35#
2	20MPa	5	-70~240	1Cr18Ni9Ti
3	40MPa	5	-20~440	35#
4	40MPa	5	-70~240	1Cr18Ni9Ti

适用于各种引进仪表装置中,与各种差压、流量、液位等变送器配套安装,由高、低压阀,平衡阀及两个校验(排污)阀组合为一体,工作时将两组校验阀与平衡阀关闭,如需检验时,只要将高、低压阀切断,打开平衡阀及打开两个校验阀,然后再关闭平衡阀即可对变送器进行在线校验或平衡。

It adopts to all kinds of gauge devices introduced from abroad. It can installed to from a complete set with all kinds of transducers for differential pressure, flow and liquid surface and others. The high & low pressure valves, balance valve and low check (drain) valves are formed as one body. When the high & low pressure valves operating close the two series of check valves and the balance valve. If the check is needed close the high & low pressure valves, and open the balance valve then close the balance valve again. At this time the transducer can be checked or balanced on line.

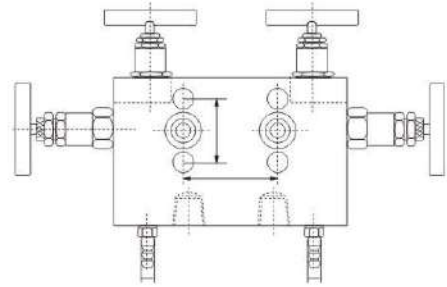
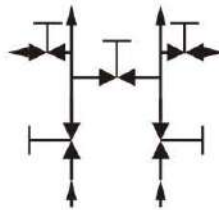
TKWF-2 五阀组
TKWF-2 Five Series Valve

序号	公称压力PN	公称口径DN	适用温度℃	阀体材料
1	20MPa	5	-20~440	35#
2	20MPa	5	-70~240	1Cr18Ni9Ti
3	40MPa	5	-20~440	35#
4	40MPa	5	-70~240	1Cr18Ni9Ti

该阀组可安装在当流量仪表远传的脉动管上,由两个取压阀,一个平衡阀以及两个排放、清洗和校验阀组成,方便建立仪表控制回路。两个排放阀使仪表不必从安装位置上移开即能排出任何腐蚀流体。

This valve is formed from two pressure-taking valves, one equalizer valve and two exhaust, washing and checking valves, can be fixed in the pulsion tubing of the flow metering gauge that is required to convey far away. It's convenient to establish the gauge control return. The two exhaust valves can drain away any corrosive fluid without moving the gauge.

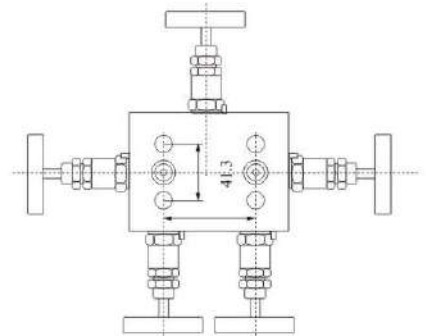
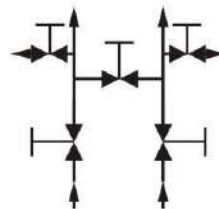
TKWF-1151 型五阀组
TKWF1151 Five Series Valve

序号	公称压力PN	公称口径DN	适用温度℃	阀体材料
1	20MPa	5	-20~440	35#
2	20MPa	5	-70~240	1Cr18Ni9Ti
3	40MPa	5	-20~440	35#
4	40MPa	5	-70~240	1Cr18Ni9Ti

适用于各种引进仪表装置中、与各种差压、流量、液位等变送器配套安装,由高、低压阀,平衡阀及两个校验(排污)阀组合为一体,工作时将两组校验阀与平衡阀关闭,如需检验时,只要将高、低压阀切断,打开平衡阀及打开两个校验阀,然后再关闭平衡即可对变送器进行在线校验和平衡。

It adopts to all kinds of gauge devices introduced from abroad, it can installed to form a complete set with all kinds of transducers for differential pressure, flow and liquid surface and others. The high & low pressure valves, balance valve and low check (drain) valves are formed as one body. When the high & low pressure valves operating close the two series of check valves and the balance valve. If the check is needed close the high & low pressure valves, and open the balance valve then close the balance valve again. At this time the transducer can be checked or balanced on line.

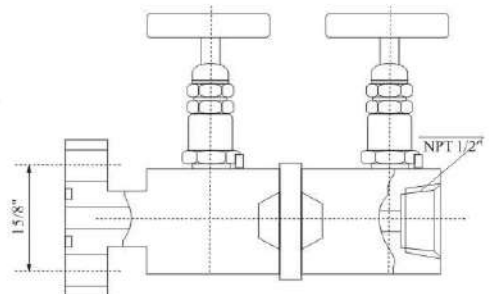
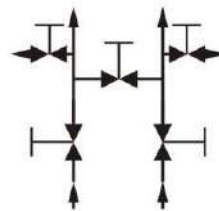
TKWF-3 法兰五阀组
TKWF-3 Five Series Valve

序号	公称压力PN	公称口径DN	适用温度℃	阀体材料
1	20MPa	5	-20~440	35#
2	20MPa	5	-70~240	1Cr18Ni9Ti
3	40MPa	5	-20~440	35#
4	40MPa	5	-70~240	1Cr18Ni9Ti

适用于各种引进仪表装置中、与各种差压、流量、液位等变送器配套安装,由高、低压阀,平衡阀及两个校验(排污)阀组合为一体,工作时将两组校验阀与平衡阀关闭,如需检验时,只要将高、低压阀切断,打开平衡阀及打开两个校验阀,然后再关闭平衡即可对变送器进行在线校验和平衡。

It adopts to all kinds of gauge devices introduced from abroad, it can installed to form a complete set with all kinds of transducers for differential pressure, flow and liquid surface and others. The high & low pressure valves, balance valve and low check (drain) valves are formed as one body. When the high & low pressure valves operating close the two series of check valves and the balance valve. If the check is needed close the high & low pressure valves, and open the balance valve then close the balance valve again. At this time the transducer can be checked or balanced on line.

TKZ系列闸阀 TKZ Gate Valves

内螺纹	楔式 闸阀 GATE VALVE	Female thread	wedge type
法兰式		Frangle type	
承插焊		inserting & welding	



本阀门适用于公称压力PN: 6.4MPa、16MPa、工作温度 $T \leq 450^{\circ}\text{C}$ 的水、蒸汽、油品等非腐蚀性介质管路上, 作启动用。产品按国外先进标准生产验收, 具有结构紧凑, 开启方便, 密封性能良好, 使用安全可靠, 较其它阀门有许多优点, 被广泛应用于炼油、化工、电力、冶金等自动控制系统中, 是目前应用最为普遍的新一代阀门。

This valve is used as starting & closing adapting to the pipe lines in which vapour, oil whose nominal pressure is PN6.4MPa, and working Temperature $\leq 450^{\circ}\text{C}$ or the corrosive materials used as the medium. The product is checked and accepted according to the foreign advanced standard. It has the characteristics of compact structure, starting convenience, good sead and safe reliable use; and has more virtues than other valves; and is widely used in the automatic systems of oil refining, chemical industry, eteclrical power, metallurgy, etc, It's really a valve of the new generation which is most universalhy used at present.

TKZ11H-64- Z11H-160 型内螺纹楔式闸阀
TKZ11Y-64- Z11Y-160
TKZ11H-64- Z11H-160 Female Thread Wedge Yype Gate Valve
TKZ 11Y-64- Z11Y-160

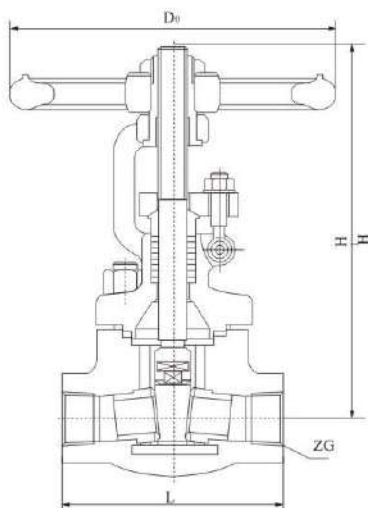

公称直径 (DN)	L	D ₀	ZG	H	H ₁	代 号	
						TKZ11H-64型	TKZ11Y-64型
10	80	100	3/8"	146	161	TKZ1-1-10	TKZ1-2-10
15	90	100	1/2"	150	167	TKZ1-1-15	TKZ1-2-15
20	90	100	3/4"	150	167	TKZ1-1-20	TKZ1-2-20
25	111	125	1"	175	198	TKZ1-1-25	TKZ1-2-25
32	121	150	1 1/4"	222	256	TKZ1-1-32	TKZ1-2-32

公称直径 (DN)	L	D ₀	ZG	H	H ₁	代 号	
						TKZ11H-160	TKZ11Y-160
10	90	100	3/8"	146	161	TKZ1-3-10	TKZ1-4-10
15	90	100	1/2"	150	167	TKZ1-3-15	TKZ1-4-15
20	111	125	3/4"	175	198	TKZ1-3-20	TKZ1-4-20
25	111	125	1"	222	256	TKZ1-3-25	TKZ1-4-25
32	121	150	1 1/4"	260	288	TKZ1-3-32	TKZ1-4-32

TKZ41H-64 Z41H-160 型法兰式楔式闸阀
TKZ41Y-64 Z41Y-160
TKZ41H-64 Z41H-160 Frange Type Wedge Yype Gate Valv
TKZ41Y-64 Z41Y-160

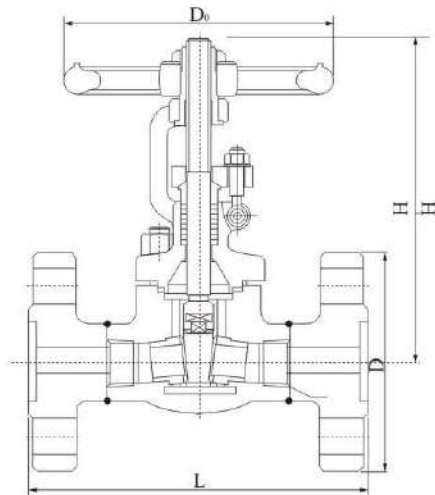

公称通径 (DN)	L	D	D ₀	H	H ₁	代号	
						TKZ41H-64型	TKZ41Y-64型
10	160	100	100	175	198	TKZ2-1-10	TKZ2-2-10
15	170	105	120	215	233	TKZ2-1-15	TKZ2-2-15
20	190	125	140	250	280	TKZ2-1-20	TKZ2-2-20
25	210	130	160	273	303	TKZ2-1-25	TKZ2-2-25
32	230	150	180	280	310	TKZ2-1-32	TKZ2-2-32

公称通径 (DN)	L	D	D ₀	H	H ₁	代号	
						TKZ41H-64型	TKZ41Y-64型
10	160	105	100	215	233	TKZ2-3-10	TKZ2-4-10
15	170	110	120	250	280	TKZ2-3-15	TKZ2-4-15
20	190	130	140	273	303	TKZ2-3-20	TKZ2-4-20
25	210	140	160	280	310	TKZ2-3-25	TKZ2-4-25
32	230	165	180	310	343	TKZ2-3-32	TKZ2-4-32

TKZ61H-64 Z61H-160 型承插焊楔式闸阀
TKZ61Y-64 Z61Y-160
TKZ61H-64 Z61H-160 Inserting & Welding Wedge
TKZ61Y-64 Z61Y-160

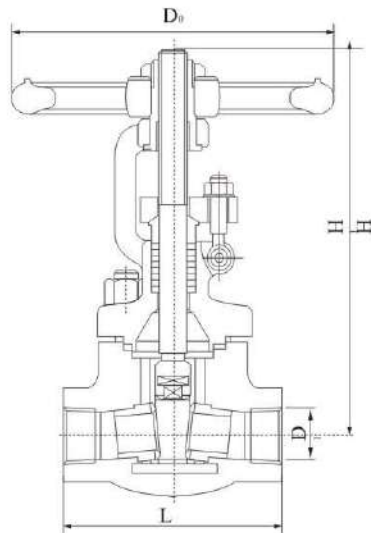

公称通径 (DN)	L	D	D ₁	I	D ₀	H	H ₁	代号	
								TKZ41H-64型	TKZ41Y-64型
10	80	40	19	10	100	146	161	TKZ3-1-10	TKZ3-2-10
15	90	40	23	12.7	125	150	167	TKZ3-1-15	TKZ3-2-15
20	110	40	28.5	13	140	175	198	TKZ3-1-20	TKZ3-2-20
25	120	46	34.5	14	150	222	256	TKZ3-1-25	TKZ3-2-25
32	130	56	43	15	160	260	300	TKZ3-1-32	TKZ3-2-32

公称通径 (DN)	L	D	D ₁	I	D ₀	H	H ₁	代号	
								TKZ41H-64型	TKZ41Y-64型
10	80	40	19	10	100	146	161	TKZ3-1-10	TKZ3-2-10
15	90	40	23	12.7	100	150	167	TKZ3-1-15	TKZ3-2-15
20	110	40	28.5	13	100	150	167	TKZ3-1-20	TKZ3-2-20
25	120	46	34.5	14	125	175	198	TKZ3-1-25	TKZ3-2-25
32	130	56	43	15	150	222	256	TKZ3-1-32	TKZ3-2-32

主要零件材料	零件名称 Part name	TKZ11H-64、TKZ41H-160	TKZ11Y-64、TKZ11Y-160
	阀体阀盖 Valve bodis and cover	锻钢 Wrought steel	锻钢 Wrought steel
	闸板、密封面 Gateboard, seal su fale	铬不锈钢 Cr-stainless steel	铬不锈钢堆焊硬质合金 Cr-stainless steel and buitwelding hard alloy
	阀杆 Valve bar	铬不锈钢 Cr-stainless steel	铬不锈钢 Cr-stainless steel
	填料 Stuffing	石棉盘根 Asbestos plate root	柔性石墨 Soft graphite

TKNG^d系列防爆挠性连接管

TKNG^d Explosion-protected Flexible Connecting Pipes

适用范围

- 爆炸性气体环境：1区、2区
- 场所中危险气体或蒸气：II A、II B、II C
- 温度组别：T1-T6
- 户内、户外（IP54、可按用户要求达到IP65）

Applying scope

- Explosive gas atmospheres: Zone 1&2
- Dangerous gases or vapors zone: II A、II B、II C
- Temperature classes: T1-T6
- Indoor and outdoor (IP54. It could be designed as IP65 according to user's requirements.)

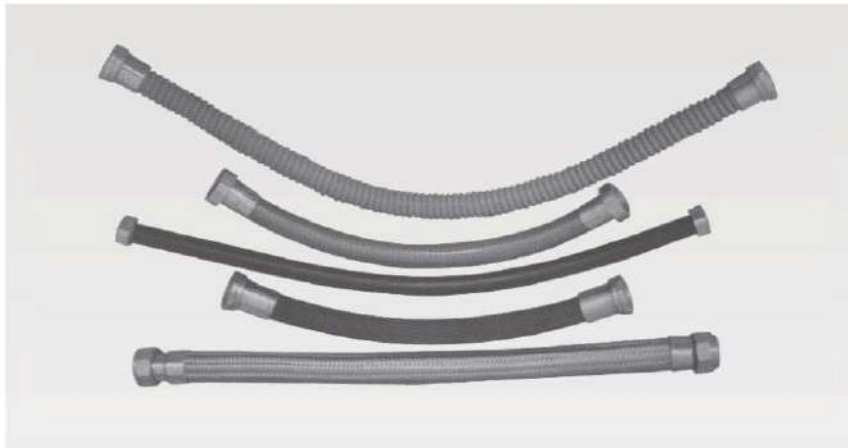

型号含义 Type designation

TKNG□-□×□□□

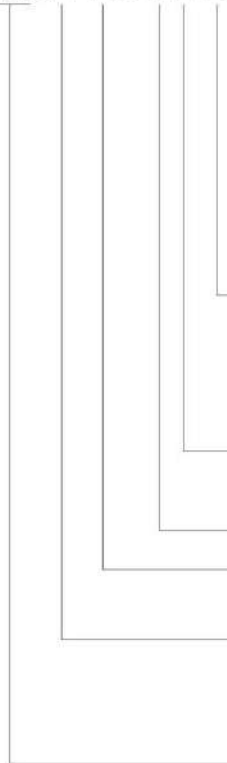

I-橡胶护套隔爆管 rubber sheath and flame-proof pipe

II-不锈钢隔爆管 stainless steel and flame-proof pipe

III-橡胶护套增安管 rubber sheath and increased safety pipe

IV-尼龙护套增安管 nylon sheath and increased safety pipe

V-包塑护套防尘管 plastic sheath and dust-proof pipe

A-两端内螺纹 A-Female thread at both ends

B-两端外螺纹 B-Male thread at both ends

不注：一端内、一端外 Female thread at one end male thread another end

总长度 Total length

管内径 Male diameter

d-隔爆型(Exd II)(II C加c、II B可不注) d-Flame proof(II C add c, II B can be neglected)

e-增安型(Exe II) e-Increased safety

Z-防尘型(DIP) s-Dust-proof(DIP)

挠性管 Flexible pipe

主要技术参数 Specification

型号 Type	螺纹公称直径(mm) Normal thread dia (mm)	长度(mm) Length(mm)	最小曲率半径(mm) Min. radius of curvature (mm)	适用电压V Voltage (V)	防爆标志 Ex-marking	承受水压MPa water pressure (MPa)
TKNG□-13(15) × 700□□	15	700	80	220/380	Exd II C Exd II B DIP	1
TKNG□-20 × 700□□	20	700	110			
TKNG□-25 × 1000□□	25	1000	145			
TKNG□-32 × 1000□□	32	1000	180			
TKNG□-38(40) × 1000□□	40	1000	210			
TKNG□-50 × 1200□□	50	1200	270			
TKNG□-63(70) × 1400□□	70	1400	340			
TKNG□-78(80) × 1400□□	80	1400	400			
TKNG□-100 × 1400□□	100	1400	520			1.5

注：1、长度可根据要求特制。

2、螺纹可按现场需要制成公制螺纹、NPT螺纹及其它。

Note. The length can be made specially by user's requirements.

2、It can be made screws into the metric system、NPT and according to site condition.

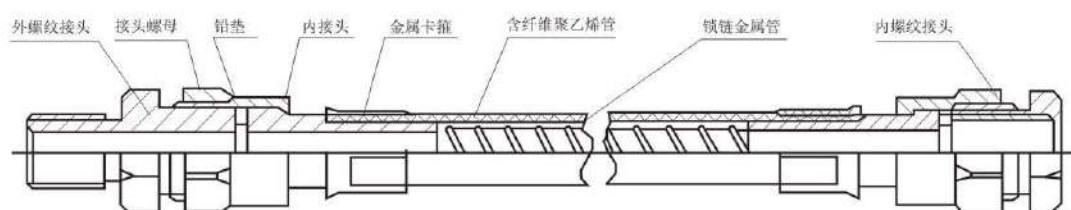

本产品具有耐燃、耐油、耐腐蚀、耐水、耐磨、耐老化、挠性良好、结构牢固、可作为防爆电气设备进山线或钢管布线弯曲难度较大的场所连接之用。

活接头螺纹加工精度不低于 H7 / g6。

This products are flame-resistant 、oil-resistant 、water resistant 、wear-resistant 、ageing-resistant 、well flexible 、solid structured 、reliable performance .

It is used for connecting inlet and outlet of explosion protected electrical apparatus or those place where the curvature is too small in wiring with conduit .

Machining precision of thread is not less than H7 / g6 .

TKBHC 系列防爆穿线盒 (e)

TKBHC Type Explosion-proof Cable-passing Box(e)

适用范围

- 1、1区、2区危险场。
- 2、IIA、IIB、IIC类爆炸性气体环境。

Application

- 1、Can be used in Zone 1 and Zone 2 dangerous places.
- 2、Can be used in IIA、IIB、IIC group explosive atmosphere.

型号含义 Model implication

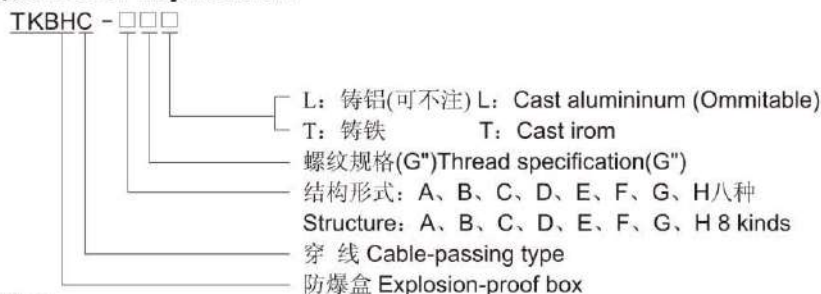

产品特点





- 1、防爆标志: Exe II。
- 2、防护等级: IP55。
- 3、外壳采用铸铝合金或铸铁, 表面喷塑, 可供用户自由选择。
- 4、结构形式多样、便于安装。
- 5、符合GB3836-2000, IEC60079标准要求。

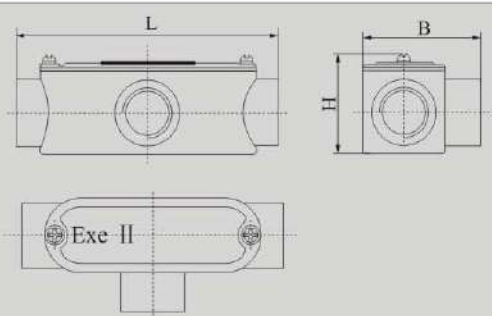

Features

- 1、Explosion-proof mark: Exe II .
- 2、Protection-proof grade: IP55.
- 3、The shell is of diecasted Al-alloy with plastic-sprayed surface, can be choised freely by user.
- 4、Varous structures, ease to install.
- 5、Suitable for GB3836-2000, IEC60079 standard request.

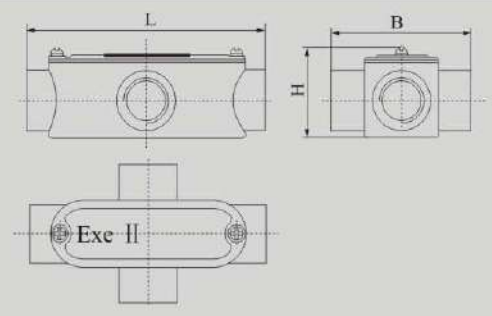
主要技术参数 Main technical parameters

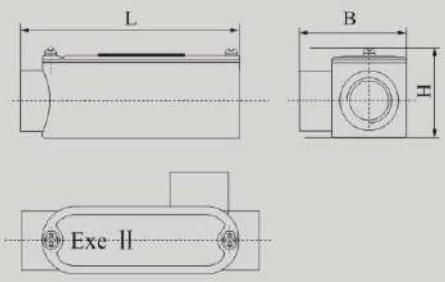

规格 Specification	铸铝 Cast A1 型号 Type		管子内径 Pipes inneral diameter	外形尺寸(mm) Outline dimension(mm)		
	铸铝 Cast A1 型号 Type	铸铁 Cast iron 型号 Type		L	B	H
1/2"	TKBHC-A1/2L	TKBHC-A1/2T	15	120	32	38
3/4"	TKBHC-A3/4L	TKBHC-A3/4T	20	135	35	48
1"	TKBHC-A1L	TKBHC-A1T	25	160	42	55
1 1/4"	TKBHC-A11/4L	TKBHC-A11/4T	32	170	54	70
1 1/2"	TKBHC-A11/2L	TKBHC-A11/2T	40	180	60	78
2"	TKBHC-A2L	TKBHC-A2T	50	228	72	90
2 1/2"	TKBHC-A21/2L	TKBHC-A21/2T	70	246	86	104
3"	TKBHC-A3L	TKBHC-A3T	80	282	102	120
4"	TKBHC-A4L	TKBHC-A4T	100	300	120	135

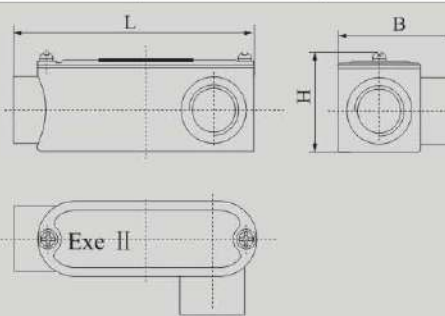
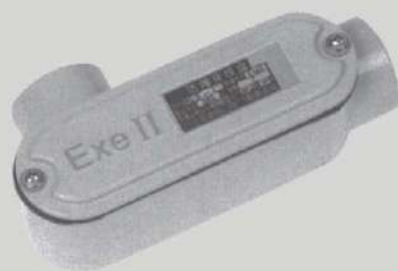
B 型 B Type						
	规格 Specification	铸铝 Cast A1 型号 Type	铸铁 Cast iron 型号 Type	管子内径 Pipes inneral diameter	外形尺寸 (mm) Outline dimension(mm)	
				L	B	H
1/2"	TKBHC-B1/2L	TKBHC-B1/2T	15	120	50	38
3/4"	TKBHC-B3/4L	TKBHC-B3/4T	20	135	60	48
1"	TKBHC-B1L	TKBHC-B1T	25	160	70	55
1 1/4"	TKBHC-B11/4L	TKBHC-B11/4T	32	170	84	70
1 1/2"	TKBHC-B11/2L	TKBHC-B11/2T	40	180	90	78
2"	TKBHC-B2L	TKBHC-B2T	50	228	104	90
2 1/2"	TKBHC-B21/2L	TKBHC-B21/2T	70	246	121	104
3"	TKBHC-B3L	TKBHC-B3T	80	282	137	120
4"	TKBHC-B4L	TKBHC-B4T	100	300	145	135
C 型 C Type						
	规格 Specification	铸铝 Cast A1 型号 Type	铸铁 Cast iron 型号 Type	管子内径 Pipe's inneral diameter	外形尺寸 (mm) Outline dimension(mm)	
				L	B	H
1/2"	TKBHC-C1/2L	TKBHC-C1/2T	15	120	68	38
3/4"	TKBHC-C3/4L	TKBHC-C3/4T	20	135	85	48
1"	TKBHC-C1L	TKBHC-C1T	25	160	98	55
1 1/4"	TKBHC-C11/4L	TKBHC-C11/4T	32	170	114	70
1 1/2"	TKBHC-C11/2L	TKBHC-C11/2T	40	180	170	78
2"	TKBHC-C2L	TKBHC-C2T	50	228	136	90
2 1/2"	TKBHC-C21/2L	TKBHC-C21/2T	70	246	156	104
3"	TKBHC-C3L	TKBHC-C3T	80	282	172	120
4"	TKBHC-C4L	TKBHC-C4T	100	300	180	135

D 型 D Type						
	规格 Specification	铸铝 Cast A1	铸铁 Cast iron	管子内径 Pipes inneral diameter	外形尺寸 (mm) Outline dimension(mm)	
型号 Type		型号 Type	L		B	H
1/2"	TKBHC-D1/2L	TKBHC-D1/2T	15	100	50	38
3/4"	TKBHC-D3/4L	TKBHC-D3/4T	20	110	60	48
1"	TKBHC-D1L	TKBHC-D1T	25	132	70	55
1 1/4"	TKBHC-D1 1/4L	TKBHC-D1 1/4T	32	140	84	70
1 1/2"	TKBHC-D1 1/2L	TKBHC-D1 1/2T	40	150	90	78
2"	TKBHC-D2L	TKBHC-D2T	50	196	104	90
2 1/2"	TKBHC-D2 1/2L	TKBHC-D2 1/2T	70	211	121	104
3"	TKBHC-D3L	TKBHC-D3T	80	247	137	120
4"	TKBHC-D4L	TKBHC-D4T	100	275	145	135
E 型 E Type						
	规格 Specification	铸铝 Cast A1	铸铁 Cast iron	管子内径 Pipes inneral diameter	外形尺寸 (mm) Outline dimension(mm)	
型号 Type		型号 Type	L		B	H
1/2"	TKBHC-E1/2L	TKBHC-E1/2T	15	100	50	38
3/4"	TKBHC-E3/4L	TKBHC-E3/4T	20	110	60	48
1"	TKBHC-E1L	TKBHC-E1T	25	132	70	55
1 1/4"	TKBHC-E1 1/4L	TKBHC-E1 1/4T	32	140	84	70
1 1/2"	TKBHC-E1 1/2L	TKBHC-E1 1/2T	40	150	90	78
2"	TKBHC-E2L	TKBHC-E2T	50	196	104	90
2 1/2"	TKBHC-E2 1/2L	TKBHC-E2 1/2T	70	211	121	104
3"	TKBHC-E3L	TKBHC-E3T	80	247	137	120
4"	TKBHC-E4L	TKBHC-E4T	100	275	145	135

规格 Specification	铸铝 Cast A1	铸铁 Cast iron	管子内径 Pipes inneral diameter	外形尺寸 (mm) Outline dimension(mm)		
	型号 Type	型号 Type		L	B	H
1/2"	TKBHC-F1/2L	TKBHC-F1/2T	15	100	30	58
3/4"	TKBHC-F3/4L	TKBHC-F3/4T	20	110	35	73
1"	TKBHC-F1L	TKBHC-F1T	25	132	42	83
1 1/4"	TKBHC-F11/4L	TKBHC-F11/4T	32	140	50	100
1 1/2"	TKBHC-F11/2L	TKBHC-F11/2T	40	150	60	108
2"	TKBHC-F2L	TKBHC-F2T	50	196	72	122
2 1/2"	TKBHC-F21/2L	TKBHC-F21/2T	70	211	86	139
3"	TKBHC-F3L	TKBHC-F3T	80	247	102	155
4"	TKBHC-F4L	TKBHC-F4T	100	275	120	160

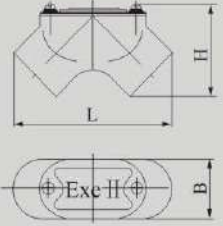
规格 Specification	铸铝 Cast A1	铸铁 Cast iron	管子内径 Pipes inneral diameter	外形尺寸 (mm) Outline dimension(mm)		
	型号 Type	型号 Type		L	B	H
1/2"	TKBHC-G1/2L	TKBHC-G1/2T	15	120	30	58
3/4"	TKBHC-G3/4L	TKBHC-G3/4T	20	135	35	73
1"	TKBHC-G1L	TKBHC-G1T	25	160	42	83
1 1/4"	TKBHC-G11/4L	TKBHC-G11/4T	32	170	50	100
1 1/2"	TKBHC-G11/2L	TKBHC-G11/2T	40	180	60	108
2"	TKBHC-G2L	TKBHC-G2T	50	228	72	122
2 1/2"	TKBHC-G21/2L	TKBHC-G21/2T	70	246	86	139
3"	TKBHC-G3L	TKBHC-G3T	80	282	102	155
4"	TKBHC-G4L	TKBHC-G4T	100	300	120	160

H型 H Type						
	规格 Specification	铸铝Cast Al 型号 Type	铸铝Cast iron 型号 Type	管子内径 Pipes inneral diameter	外形尺寸(mm) Outline dimension(mm)	
				L	B	H
1/2"	TKBHC-H1/2L	TKBHC-H1/2T	15	120	30	58
3/4"	TKBHC-H3/4L	TKBHC-H3/4T	20	135	35	73
1"	TKBHC-H1L	TKBHC-H1T	25	160	42	83
1/4"	TKBHC-H11/4L	TKBHC-H11/4T	32	170	50	100
1/2"	TKBHC-H11/2L	TKBHC-H11/2T	40	180	60	108
2"	TKBHC-H2L	TKBHC-H2T	50	228	72	122
2 1/2"	TKBHC-H21/2L	TKBHC-H21/2T	70	246	86	136
3"	TKBHC-H3L	TKBHC-H3T	80	282	102	139
4"	TKBHC-H4L	TKBHC-H4T	100	300	120	142

TKBXJ51 系列防爆接线箱 (e、II B、II C)

TKBXJ51 Type Explosion-proof Junction Box(e, II B, II C)

适用范围

- 1、I区、2区危险场所。
 - 2、II A、II B、II C类爆炸性气体环境。
- *如要求 II B或 II C类请注明。

Application

- 1、Can be used in Zone 1 and Zone 2 dangerous places.
 - 2、Can be used in II A、II B、II C group explosive atmosphere.
- *Please note in want II B and II C group.

型号含义 Model implication

TKBXJ51-□/□D□(□)L□(□)X□(□)R□(□)



产品特点

- 1、铸铝合金外壳，表面喷塑。
- 2、压铸成形，外形美观。
- 3、结合面采用曲路密封结构，具有较强的防水、防尘性能。
- 4、接线端子采用增量型专用端子，接线方便，牢固可靠，并且电流大小有多种规格可供用户任意选配。
- 5、进线口方向变化多端，可根据用户要求任意选配进线口并可根据用户要求直接配装DQM系列的电缆密封接头（注：用户在订货时须注明）。
- 6、符合GB3836-2000，IEC60079标准要求。

Features

- 1、Diecasted aluminium alloy shell with plastic-sprayed surface.
- 2、Diecasted into shape, beautiful appearance.
- 3、The interface use curve-seal structure, having the strong functions of water-proof, dust-proof.
- 4、Use safety-increased special terminal, convenient to connect, secure and reliable, the currents specification can be determined by clients.
- 5、The direction of inlet can be determined by clients, selecting inlet can be filled with DQM series cable sealing connector as required (Note: Indicate if oredring)
- 6、Suitable for GB3839-2000, IEC60079 standard request.

进线示意图 Inlet diagram

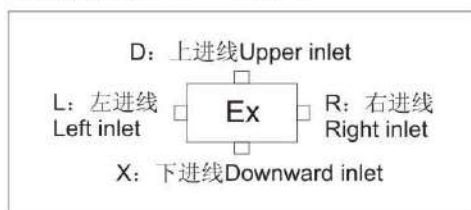

主要技术参数 Main technical parameters

额定电压(V) Rated voltage	额定电流(A) Rated current	防爆标志 Ex-mark	防护等级 Protection grade
380	20	Exe II T6 *Exe II BT6 *Exe II CT6	IP54

外形举例 Outline example

增安型接线箱外形举例 Outline example of safety-increased junction box

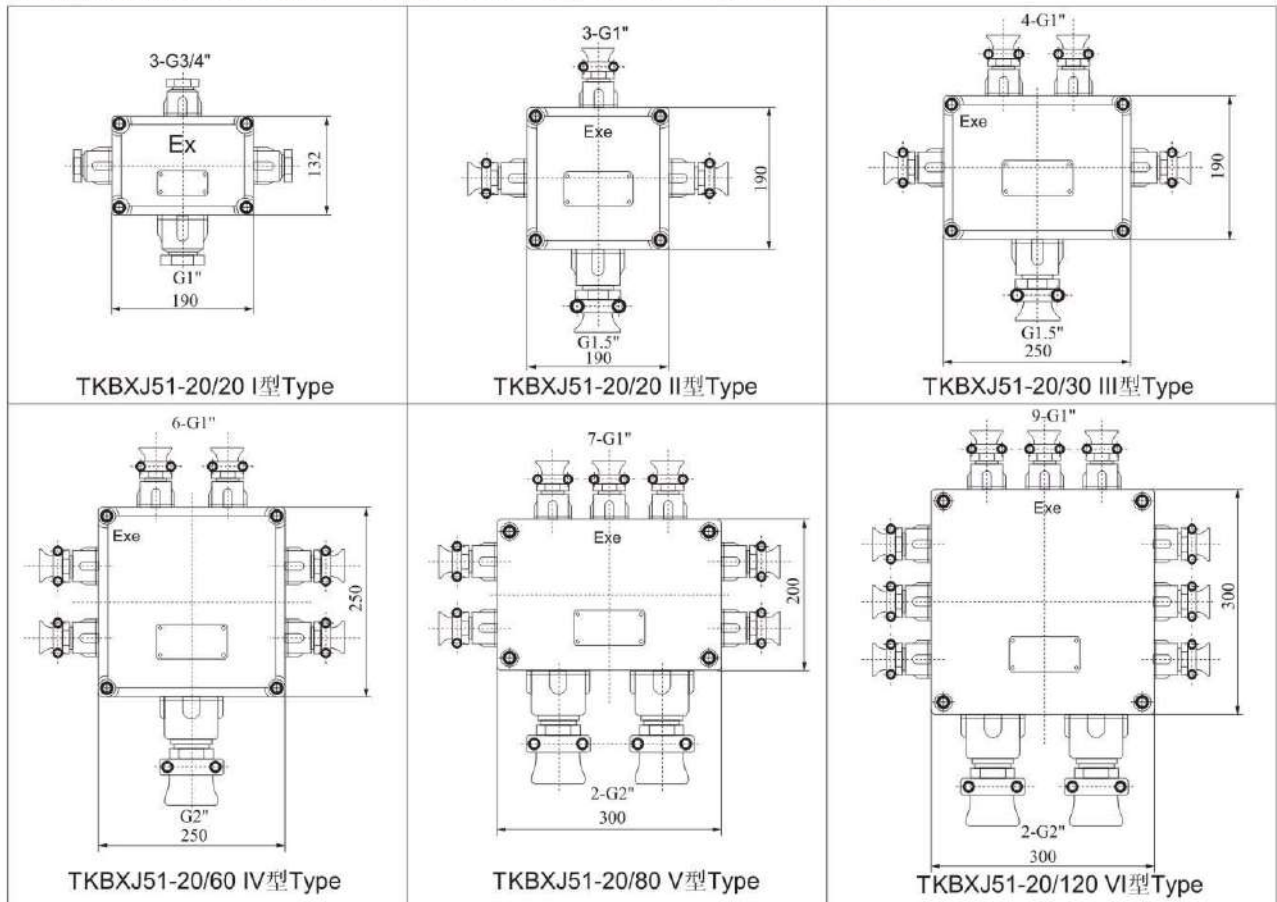

II B类接线箱外形举例 Outline example of II B group junction box

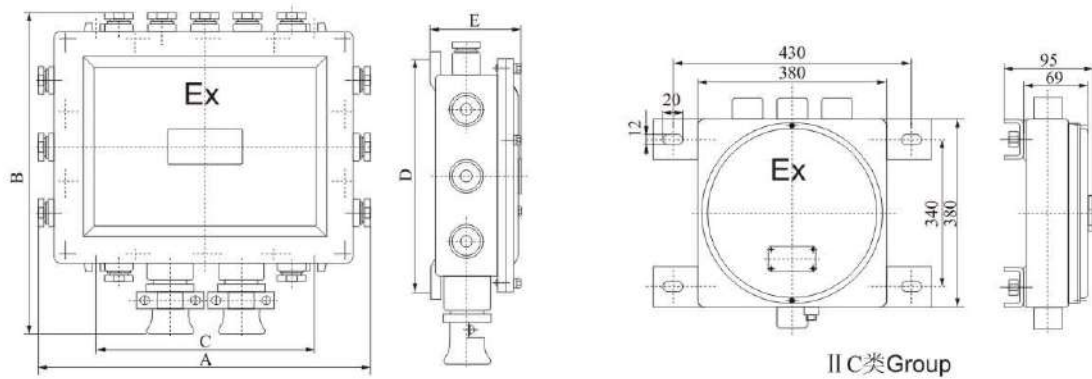

II B类外形见下表 Outline of II B group as follow

型号 Type	A	B	C	D	E	进出线口规格(数量) Inlet and outlets specification (No.)		备注 Remark
TKBXJ51-20/4	204	185	160	82	100	1-G3/4"	4-G1/2"	Exd II BT6
TKBXJ51-20/8	242	245	196	104	110	1-G1"	7-G3/4"	
TKBXJ51-20/16	318	332	172	206	110	1-G11/2"	7-G3/4"	
TKBXJ51-20/24	422	338	276	224	110	1-G11/2"	11-G3/4"	
TKBXJ51-20/36	422	412	276	299	114	2-G11/2"	13-G3/4"	

TKZxd、Hxd、Psd 系列防爆隔离密封管接头

TKZxd、Hxd、Psd series Flame-proof Sealing Connector

适应范围

爆炸性气体环境：1区、2区
 场所中危险气体和蒸气：IIA、IIB、IIC
 温度组别：T1-T6
 户内、户外（IP54、可按用户要求达到IP65）

Applying scope

Explosive gas atmospheres: Zone 1&2
 Dangerous gases or vapors zone: IIA、IIB、IIC
 Temperature classes: T1-T6
 Indoor and outdoor (IP54. It could be designed as IP65 according to use s requirements.)



型号含义 Type designation

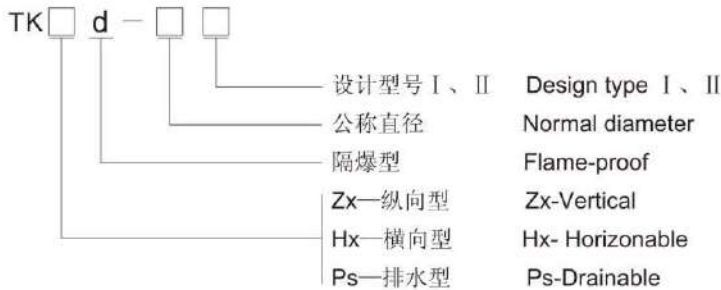

产品特点

- ◇铸铝合金外壳，表面喷塑。
 - ◇钢管布线。
- Features
- ◇Enclosure is made of casting aluminum alloy, surface is sprayed with plastics.
 - ◇wiring with conduit.

技术参数及外形尺寸 Specification and outline dimensions

公称直径 Normal Dia.	Zxd-□ I		Zxd-□ II		电缆外径Φ Cable Dia.(mm)
	A	B	A	B	
G13	100	80	100	61	7-9
G20	100	85	100	67	8-15
G25	110	90	130	73	10-18
G32	115	96	130	83	13-23
G38	120	116	130	89	17-26
G50	120	120	150	101	25-35
G63	165	152	170	115	29-38
G75	200	175	215	132	33-51
G100	220	223	245	165	42-60

公称直径 Normal Dia.	Hxd-□		Hxd-□		电缆外径Φ Cable Dia.(mm)
	A	B	A	B	
G13	95	65	100	75	7-9
G20	95	72	100	80	8-15
G25	110	80	100	90	10-18
G32	110	98	124	95	13-23
G38	110	104	124	110	17-26
G50	130	117	124	120	25-35
G63	170	135	185	140	29-38
G75	215	176	215	168	33-51
G100	245	211	245	182	42-60

TKYFD 型有机防火堵料

TKYFD Fire - proof Organic Material

TKYFD型有机防火堵料俗称“密封胶泥”，是一种新型防火堵料，其主要特点是具有可塑性，施工、维修时比较方便，能防鼠咬，有良好的阻火堵烟隔离密封性能，耐火时间大于3小时，主要用于电线贯穿孔洞封堵，以防止电线电缆发生火灾时由孔洞向邻室蔓延，避免事故的扩大，配合使用ZHD、HXD、PSD隔离密封接头，防爆效果更佳，因此该堵料是工矿企业、高层建筑、造船、发电、冶金、邮电等配线系统理想的防火堵料。

TKYFD fire-proof organic , popular name as “sealing compound is a new type fire-proof material .Its best feature is plasticity ,so it is very convenient to construct and maintain .It prevents mouse biting .It has good feature of fire proof and stopping up smoke .The fire- resistant time is more than 3 hours. It is used to stop up a hole where cable pass through it, so it can prevent flame from spread if cable fire for avoiding more losing. It's better to use ZHD,HXD,PSD seal ring at same time. It's the best choice for cable wiring system of enterprise, high level building, shipbuilding, power plant ,metallurgy, post and telecommunications.



主要技术数据 Specification

名称 Name	技术参数 Specification
外观 Outward	塑性固体，具有一定的柔韧性 Plastics Solid
密度 $\text{kg/m}^3 \leq \text{Density} \text{ kg/m}^3 \leq$	20×10^3
耐水性 $d \geq \text{Water-proof} \text{ d} \geq$	3, 无溶胀 3, No Expand
耐油性 $d \geq \text{Oil-proof} \text{ d} \geq$	3, 无溶胀 3, No Expand
腐蚀性 $d \geq \text{Corrosion-proof} \text{ d} \geq$	7
耐火时间 $\text{Min} \geq \text{Fire-proof Time} \text{ d} \geq$	180(一级) 180(One Class)
表面电阻系数 (Ω) Resistance Coefficients (Ω)	$\geq 1 \times 10^{10}$
腐蚀性 (对铝、铁、钢、不锈钢、塑料、橡胶) Corrosion (For Aluminium, Iron, Steel, Stainless Steel, Plastics, Rubber)	无异常 Nounusual

使用方法及用量计算 Apply and amount

该堵料揉匀后均匀地嵌满孔洞。如气温过低，可将堵料适当升温(以不大于40℃为宜)，待柔软后取出使用。填充孔洞体1M³需要该堵料约1.8T。

This material is kneaded even and filled in the hole. If the temperature is too low, it may heat up (not more than +40 ℃) and use when its supple. Fill 1M³ hole, 1.8T of this material is needed.

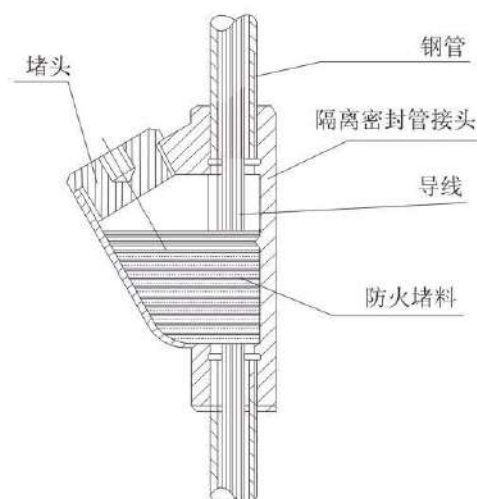

TKBHJ 系列防爆活接头 (d II)

TKBHJ Type Explosion-proof Active Connector(d II)

适用范围

- 1、1区、2区危险场所。
- 2、II A、II B、II C类爆炸性气体环境。

Application

- 1、Can be used in Zone 1 and Zone 2 dangerous places.
- 2、Can be used in II A、II B、II C groups explosive atmosphere.



型号含义 Model implication

TKB HJ □ - □ (□) / □ (□)

- 螺纹规格(内或外) Thread specification (Inner of outer)
- 螺纹规格(内或外) Thread specification (Inner of outer)
- I: 碳钢(可不注) I: Steel (Omittable)
- II: 不锈钢 II: Stainless steel
- 接头 Connector
- 防爆 Explosion-proof type

产品特点

- 1、优质碳钢制成，表面镀锌或采用不锈钢。
- 2、螺纹规格可特制，如NPT螺纹，公制螺纹等。
注：标注螺纹规格时应注明内外螺纹。如HYBHJ-G3/4"(内)/G"(外)意义为一端为内螺纹G3/4"，一端为外螺纹G1"。
- 3、符合GB3836-2000，IEC60079标准要求。

Features

- 1、The product is made of carbon steel adopting galvanized surface or stainless steel.
- 2、Thread can be specially made.
Note: Please note inner and outer thread specification when noting the thread. For example: HYBHJ-G3/4" (inner) / G1" (outer) means: Its one terminal is inner thread G3/4", another terminal is outer thread G1".
- 3、Suitable for GB3836-2000, IEC60079 standard request.

主要技术参数 Main technical parameters

公称直径 Nominal diameter	尺寸 size		防护等级 Protection grade	防爆标志 Ex-mark	防腐等级 Corrosion-proof grade	电缆外径 (Φ, mm) Cables outer diameter	质量(Kg) mass
	D	L					
G1/2"	43	62	IP55	Exd II	WF1	6.5~10	0.25
G3/4"	50	62				10~14	0.22
G1"	58	70				12~17	0.31
G1 1/4"	70	75				15~23	0.52
G1 1/2"	74	75				18~26	0.56
G2"	85	90				26~34	0.64
G2 1/2"	100	110				30~43	0.82
G3"	118	120				38~51	0.94

外形举例 Outline example

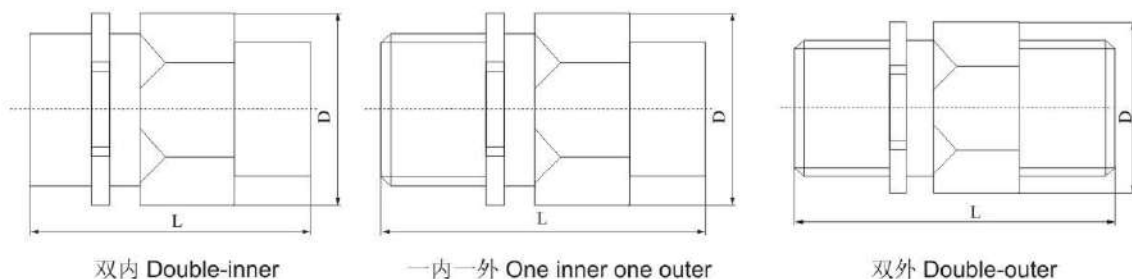

TKDQM 系列电缆夹紧密封接头 (d II、e)

TKDQM Type Cable-clamped Seal Connector(d II, e)

型号含义 Model implication

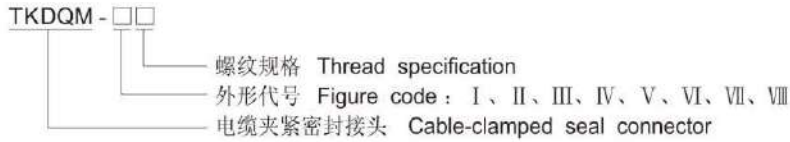

I 型: 采用工程塑料压制而成, 具有较强的防腐和防水性能, 适用于增安型外壳中作引入装置用。

I:

型号 Type	电缆外径 Cables outer diameter	螺纹长度 Thread length	L	防爆标志 Ex-mark	防护等级 Protection grade
TKDQM-I PG9	5~8	8	55	Exe II	IP68
TKDQM-I PG11	5~10	8	55		
TKDQM-I PG13.5	6~12	9	67		
TKDQM-I PG16	10~14	10	67		
TKDQM-I PG21	13~18	11	72		
TKDQM-I PG29	18~25	11	72		
TKDQM-I PG36	22~32	13	77		
TKDQM-I PG42	30~38	13	77		
TKDQM-I PG48	34~44	13	89		



I 型 Type I

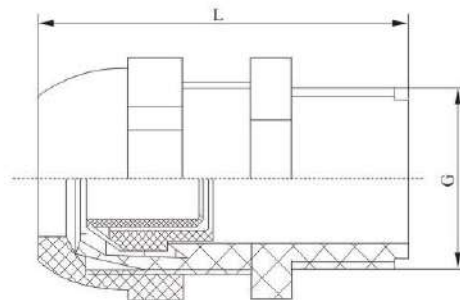

II 型: 采用优质钢或不锈钢制作, 采用机械式电缆夹紧装置。

Type II: Made of high-quality steel or stainless steel by mechanical cable-clamped device.

型号 Type	电缆外径 Cables outer diameter	L	防爆标志 Ex-mark	防护等级 Protection grade
TKDQM-II G1/2"	7~9	55	Exe II	IP68
TKDQM-II G3/4"	8~14	55		
TKDQM-II G1"	12~17	67		
TKDQM-II G1 1/4"	13~23	72		
TKDQM-II G1 1/2"	17~26	77		
TKDQM-II G2"	25~35	89		

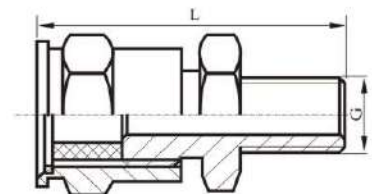

II 型 Type II

III 型：采用优质钢或不锈钢制作，采用铸铝机械式电缆夹紧装置。

Type III: Made of high-quality steel or stainless steel by mechanical cable-clamped device.

型号 Type	电缆外径 Cable's outer diameter	L	防爆标志 Ex-mark	防护等级 Protection grade
TKDQM-III G1/2"	7~9	86	Exd II	IP68
TKDQM-III G3/4"	8~14	87		
TKDQM-III G1"	12~17	113		
TKDQM-III G1 1/4"	13~23	130		
TKDQM-III G1 1/2"	17~26	130		
TKDQM-III G2"	25~35	142		
TKDQM-III G2 1/2"	29~38	142		
TKDQM-III G3"	33~51	158		



III 型 Type III

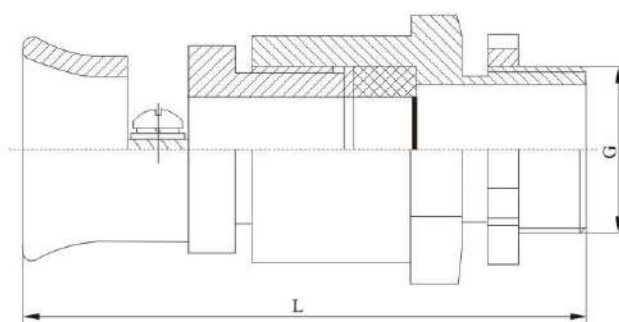

IV 型：采用优质钢或不锈钢制作，采用铸铝机械式电缆夹紧装置。

Type IV: Made of high-quality steel or stainless steel by mechanical cable-clamped device.

型号 Type	电缆外径 Cable's outer diameter	L	防爆标志 Ex-mark	防护等级 Protection grade
TKDQM-IV G1/2"	7~9	55	Exd II	IP68
TKDQM-IV G3/4"	8~14	55		
TKDQM-IV G1"	12~17	67		
TKDQM-IV G1 1/4"	13~23	67		
TKDQM-IV G1 1/2"	17~26	72		
TKDQM-IV G2"	25~35	72		
TKDQM-IV G2 1/2"	29~38	77		
TKDQM-IV G3"	33~51	89		



IV 型 Type IV

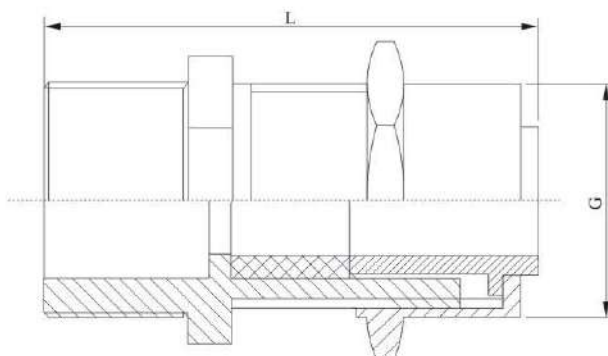

V 型：采用优质钢或不锈钢制作，采用机械式电缆夹紧装置。

Type V: Made of high-quality steel or stainless steel by mechanical cable-clamped device.

型号 Type	电缆外径 Cables outer diameter	L	防爆标志 Ex-mark	防护等级 Protection grade
TKDQM-V G1/2"	7~9	70	Exd II	IP68
TKDQM-V G3/4"	8~14	70		
TKDQM-V G1"	12~17	82		
TKDQM-V G1 1/4"	13~23	82		
TKDQM-V G1 1/2"	17~26	87		
TKDQM-V G2"	25~35	92		
TKDQM-V G2 1/2"	29~38	92		
TKDQM-V G3"	33~51	100		



V 型 Type V

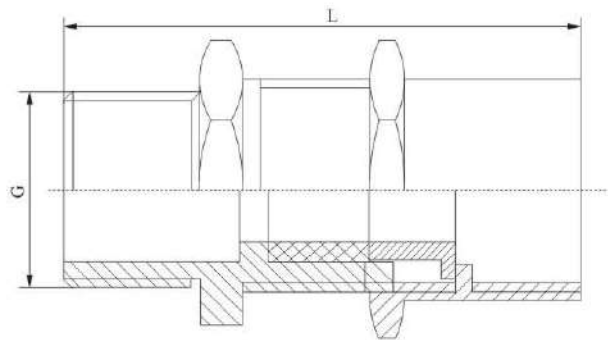

VI 型：采用优质钢或不锈钢制作，采用机械式电缆夹紧装置。

Type VI: Made of high-quality steel or stainless steel by mechanical cable-clamped device.

型号 Type	电缆外径 Cables outer diameter	L	防爆标志 Ex-mark	防护等级 Protection grade
TKDQM-V G1/2"	7~9	55	Exd II	IP68
TKDQM-V G3/4"	8~14	55		
TKDQM-V G1"	12~17	67		
TKDQM-V G1 1/4"	13~23	67		
TKDQM-V G1 1/2"	17~26	72		
TKDQM-V G2"	25~35	77		
TKDQM-V G2 1/2"	29~38	77		
TKDQM-V G3"	33~51	89		



VI 型 Type VI

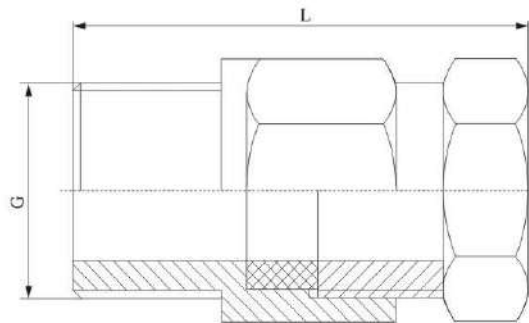

VII 型：采用优质钢或不锈钢制作，采用机械式电缆夹紧装置。

Type VII: Made of aluminium alloy by mechanical cable-clamped device.

异径 Recucer		尺寸 Size		防护等级 Protection grade	电缆外径(Φ, mm) Cables outside diameter	质量(Kg) weigh
A	B	C	D			
G15	12	30	25	IP68	7~9	0.06
G20	12	40	35		8~14	0.06
G25	12	50	45		12~17	0.16
G32	15	60	50		13~23	0.30
G40	30	80	78		17~26	0.34
G50	30	90	80		25~35	0.46
G70	30	110	85		29~38	1.12



VII 型 Type VII

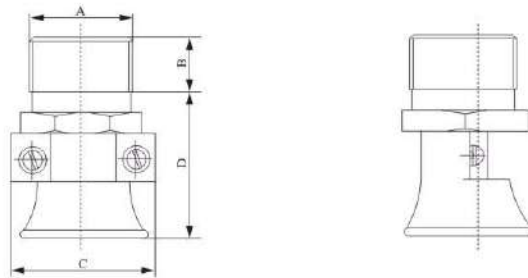

TKDQM 系列铠装电缆夹紧密封接头 (d II、e)

TKDQM Type Cable-clamped Seal Connector(d II, e)

VIII 型：采用不锈钢或优质钢制作，采用机械式电缆夹紧装置。

Type VIII: Made of aluminium alloy by mechanical cable-clamped device.

序号	M	L ₁	D ₀	D ₁		S	D	L
1	NPT1/2"	16.5	12	8.5	16	24	26.5	73
2	NPT1/2"	16.5	16	15.5	21	30	33	77
3	NPT3/4"	16.5	21	21	27	36	41.5	82
4	NPT1"	16.5	28	27	34	46	51	82
5	M16×1.5	15	15	8.5	16	24	26	60
6	M20×1.5	15	20	11	16	24	26.5	76
7	M20×1.5	15	15	15	22	30	33	65
8	M25×1.5	12	20	15	22	30	33	65
9	M25×1.5	15	15	21	28	36	41.5	76
10	M32×1.5	15	25.5	26	34	46	51	80
11	M50×1.5	15	44	45	54	71	78	85



VIII 型 Type VIII

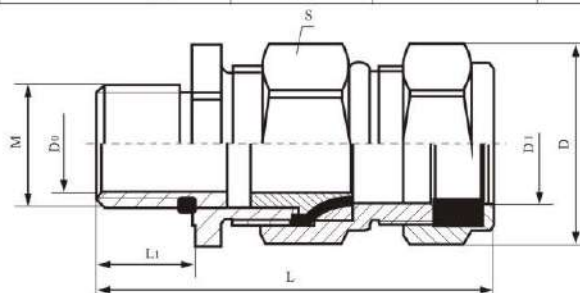

TKDTL 系列防爆填料函 (d II)

TKDTL Type Explosion-proof Gasketing Tube (d II)

适用范围

- 1、1区、2区危险场所。
- 2、II A、II B、II C类爆炸性气体环境。

Application

- 1、Can be used in Zone 1 and Zone 2 dangerous places.
- 2、Can be used in II A、II B、II C group explosive atmosphere.

型号含义 Model implication

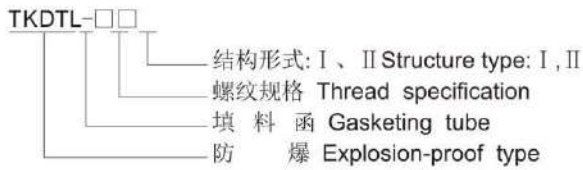

产品特点

- 1、采用黄铜或不锈钢制成，如要求不锈钢请注明。
- 2、电缆采用填料密封。
- 3、防护性能良好。
- 4、具有使用、安装方便，结构安全可靠，防爆性能优越等特点。
- 5、符合 GB3836-2000，IEC60079 标准要求。

Features

- 1、Made of brass or stainless steel, please note if require stainless steel.
- 2、Cable is applied to gasket seal.
- 3、High protection.
- 4、Ease to use and install, safety, security, explosion-proof.
- 5、Suitable for GB3836-2000, IEC60079 standard request.

主要技术参数 Main technical parameters

产品型号 Type	防爆标志 Ex-mark	防护等级 Protection grade	电缆外径(Φ,m) Cables outer diameter	L(mm)(图1 map1)
TKBTL-G1/2"	Exd II	IP68	3~8	72
TKBTL-G3/4"			10~14	74
TKBTL-G1"			11~19	84
TKBTL-G1 1/4"			17~26	88
TKBTL-G1 1/2"			22~32	93
TKBTL-G2"			29~44	95
TKBTL-G2 1/2"			40~56	103
TKBTL-G3"			52~68	126

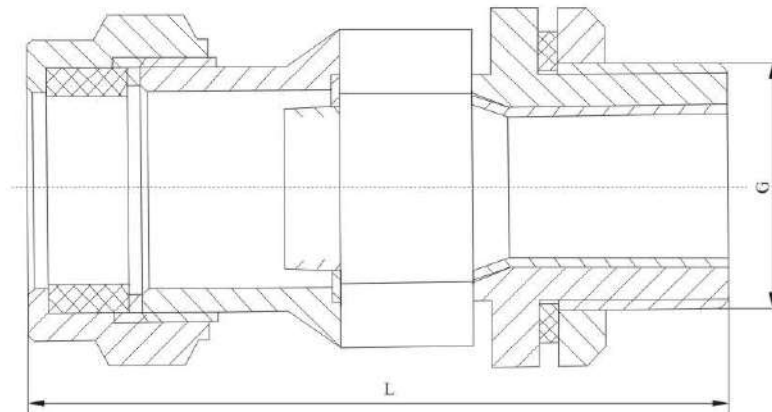

I 型结构示意图 | Type structure sketch map

TKDGJ 系列防爆管接头 (d II)

TKDGJ Type Explosion-proof Pipe Connector(d II)

适用范围

- 1、1区、2区危险场所。
- 2、II A、II B、II C类爆炸性气体环境。

Application

- 1、Can be used in Zone 1 and Zone 2 dangerous places.
- 2、Can be used in II A、II B、II C group explosive atmosphere.



型号含义 Model implication

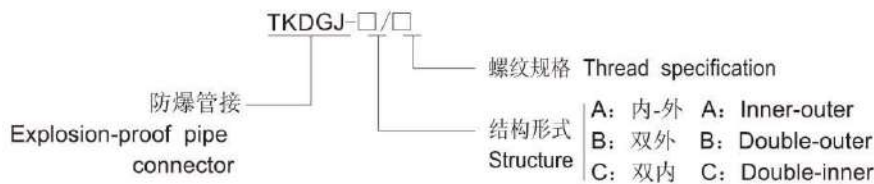

产品特点

- 1、防爆标志: Exd II。
- 2、优质碳素钢制成。
- 3、螺纹规格可根据用户要求特制。
- 4、符合 GB3836-2000, IEC60079 标准要求。

Features

- 1、Ex-mark: Exd II.
- 2、Made of good carbon-steel.
- 3、The thread specification can be provided particularly by user.
- 4、Suitable for GB3836-2000, IEC60079 standard request.

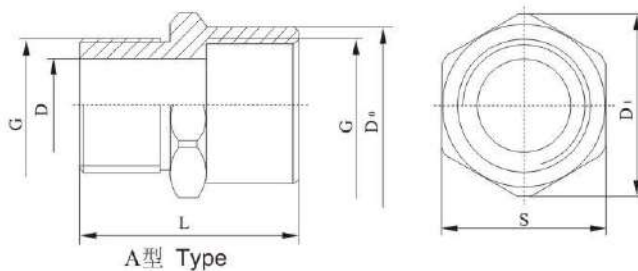

D ₁	S	D ₀	D	L	G
30	27	25	13	40	1/2"
36	32	31	18	40	3/4"
42	38	37	25	48	1"
52	47	46	32	48	1 1/4"
60	55	54	38	48	1 1/2"
70	66	65	50	54	2"
88	83	82	65	54	2 1/2"
100	95	94	75	60	3"
127	122	121	100	60	4"

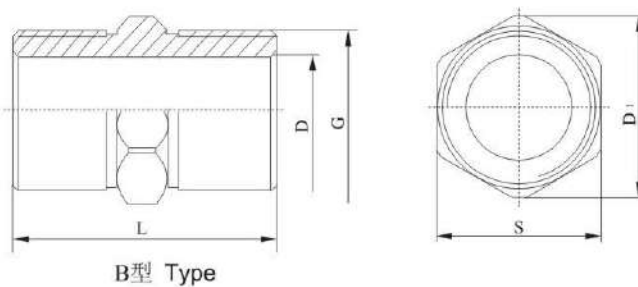

D ₁	S	D	L	G
25	22	13	40	1/2"
30	27	18	40	3/4"
40	35	24	48	1"
50	45	32	48	1 1/4"
58	52	38	48	1 1/2"
67	62	50	54	2"
85	80	65	54	2 1/2"
98	93	75	60	3"
125	120	100	60	4"

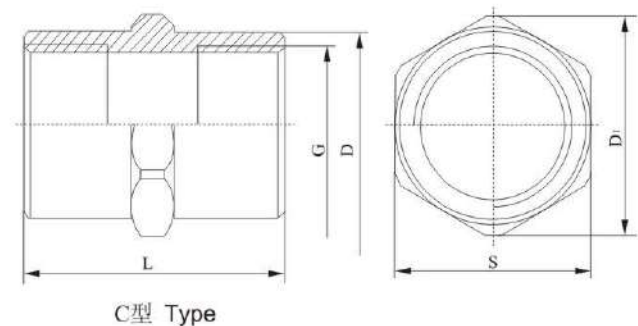

D ₁	S	D	L	G
30	27	25	40	1/2"
36	32	31	40	3/4"
42	38	37	48	1"
52	47	46	48	1 1/4"
60	55	54	48	1 1/2"
70	66	65	54	2"
88	83	82	54	2 1/2"
100	95	94	60	3"
127	122	121	60	4"

TKDGJ-b系列防爆变径接头 (dII)

TKDGJ-b Type Explosion-proof Ruccker Connector(dII)

适用范围

- 1、1区、2区危险场所。
- 2、II A、II B、II C类爆炸性气体环境。

Application

- 1、Can be used in Zone 1 and Zone 2 dangerous places.
- 2、Can be used in II A、II B、II C group explosive atmosphere.

产品特点

- 1、防爆标志：Exd II。
- 2、优质碳素钢制成。
- 3、螺纹规格可根据用户要求特制。
- 4、符合GB3836-2000，IEC60079标准要求。

Features

- 1、Ex-mark：Exd II.
- 2、Made of good carbon-steel.
- 3、The thread specification can be provided particularly by user.
- 4、Suitable for GB3836-2000, IEC60079 standard request.



型号含义 Model implication

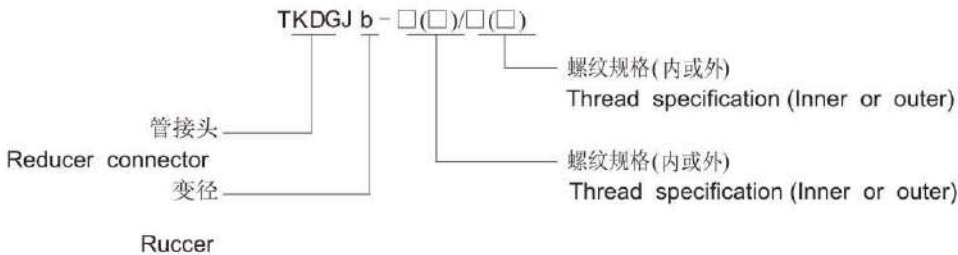

外形示意 Outline and mounting example

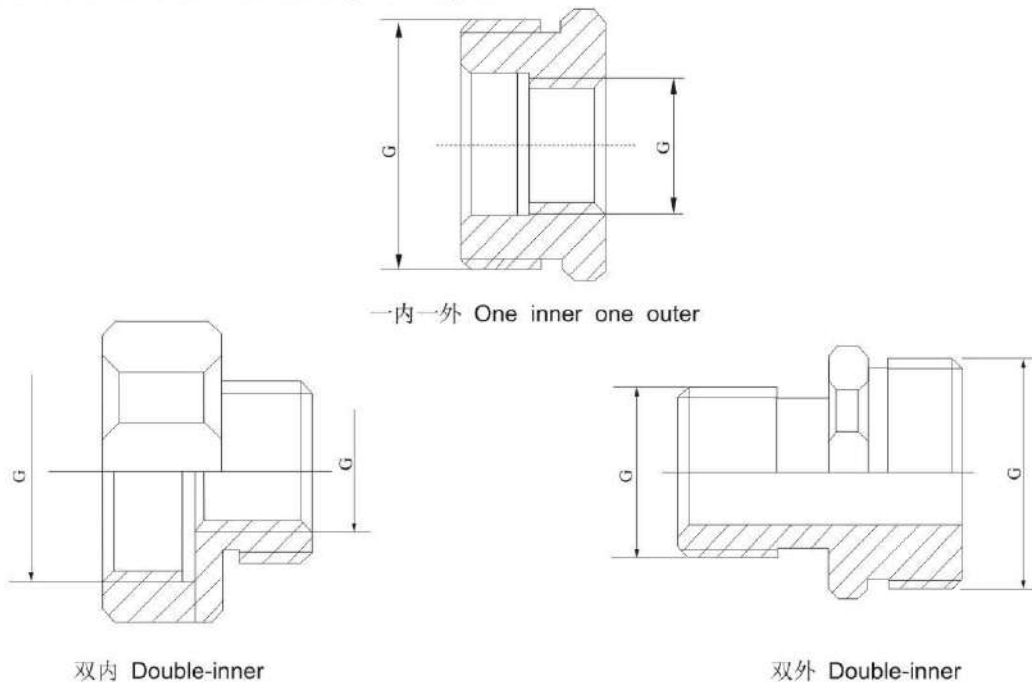

TKHBC补偿式防堵吹扫装置

TKHBC Compensation Anti - Blocking Purge Device

概述

防堵取样、准确测量，是电厂在风压测量中多年来的一贯追求。对锅炉运行中的一些重要参数（如炉膛压力、烟气压力、磨煤机压力、一、二、三次风压、返料风室压力、料层差压等）必须解决防堵问题才能进行连续准确的测量。目前电厂的防堵取压一般采用常规的防堵取样器（内置三层防堵机构），自清灰（静、动压）取样器和连续吹扫防堵装置等等，这些产品在防堵取压上虽有一点效果，但不很明显，还是经常要出现堵塞现象。特别是硫化床锅炉就更容易堵塞，硫化床炉膛内的燃料是利用强大的风流使物料流动起来进行充分燃烧，其炉膛内的硫化情况是一个重要运行参数，但流动的物料极易堵塞常规的防堵取样器，给锅炉的安全运行带来一定的影响。

针对上述情况，我厂根据多年从事风压取样防堵的研究成果，综合流体力学的原理研制出了TKHBC环保型补偿式防堵装置。该装置完全彻底的解决了既要防堵又要测量准确的问题，国内其它厂家同类产品的补偿装置置于控制箱内，迫使控制箱与测压点之间的距离在4米之内，我厂的HBC环保型补偿式防堵吹扫装置将补偿装置置于取样器内，使控制箱与测压点之间的距离在200米以内确保准确测量。且加装了调压稳压器，完全解决了电厂气源不稳不净的问题，确保了流量控制器的正常运行。该装置的应用为电厂锅炉安全可靠的运行提供了有力的保证。

该装置具有结构合理、安装方便、永不堵塞、测量准确等优点，在电力、石油、化工、冶金、建材工业中将得到广泛的应用。

主要技术指标

- 1、仪表气源压力： $\geq 0.6\text{Mpa}$
- 2、测量误差： $\leq 0.5\text{H}20\text{mm}$
- 3、内反吹耗气量： $0.5 \sim 1.5\text{m}^3/\text{h}$ 压力 0.24Mpa （可调）
- 4、使用环境： $-30 \sim 70^\circ\text{C}$ ，相对湿度： $\leq 95\%$
- 5、防护等级：IP56
- 6、吹扫装置取样头材质采用 $1\text{Cr}18\text{Ni}9\text{Ti}$

主要特点

- 1、利用流体力学的动压补偿方法，真实的在线反映各测点的压力值。
- 2、吹扫的压力大于被测的压力完全彻底解决了多粉尘和高温状态下压力测量管路的堵塞和烧毁现象。
- 3、采用了调压稳压器，可对电厂提供的气源进行稳压，确保流量控制器输出流量的稳定，并能达到长时间的可靠运行。
- 4、不需进行人工吹扫，大大减轻了运行中的维护工作和工人的劳动强度。
- 5、控制箱采用IP56结构，外形美观，尺寸小，易于维护，安装简便。
- 6、该装置最大的特点在于采用一体化结构先进合理的补偿方法，既适用于静压测量，也适用于差压测量。控制箱与测压点之间的距离由同类产品的4米增加至200米。

结构与原理

1、结构

TKHBC环保型补偿式防堵吹扫装置有二大部分组成：恒气流控制箱和压力吹扫取样（头）器（内置补偿器）。

（见图一）

Introduction

Anti-blocking sampling and accurate measurement are the consistent pursuit of power plant in wind pressure measurement for many years. For some important parameters in boiler operation (such as furnace pressure, Flue gas pressure, coal mill pressure, one, two, three times wind pressure, return air chamber pressure, material layer differential pressure, etc. At present, the anti-blocking and pressure-taking of power plant generally adopts conventional anti-blocking sampler (built-in three-layer anti-blocking mechanism), self-cleaning (static and dynamic pressure) sampler and continuous purging anti-blocking device, etc. Although these products have a little effect on the anti-blocking and pressure-taking, it is not obvious, but often there will be blockage. Especially, the vulcanized bed boiler is more easily blocked, the fuel in the vulcanized bed furnace chamber is to use the strong air flow to make the material flow up for full combustion, the vulcanization situation in the furnace chamber is an important operating parameter, but the flowing material is easy to block the conventional anti-blocking sampler, to the safe operation of the boiler has a certain impact.

In view of the above situation, our factory has developed the TKHBC environmental protection compensation anti-blocking device based on the research results of wind pressure sampling for many years. The device completely thoroughly solved is to prevent and to measure the exact problem, the domestic similar products of other manufacturers compensation device in the control cabinet and force control box and the distance between the pressure measuring point within 4 meters, our factory held in green compensating HBC purging device in the compensation device in the sampler, the control box and the distance between the pressure measuring point within 200 meters to ensure accurate measurement. Moreover, a voltage regulator is installed to solve the problem of unstable and unclean power supply and ensure the normal operation of the flow controller. The application of this device provides a powerful guarantee for the safe and reliable operation of power plant boilers.

This device has the advantages of reasonable structure, This device has the advantages of reasonable structure, easy installation, never clogging and accurate measurement, and will be widely used in electric power, petroleum, chemical industry, metallurgy and building materials industry.

Main technical indicators

1. Air pressure of the instrument: $\geq 0.6\text{Mpa}$
2. Measurement error: $\leq 0.5\text{H}20\text{mm}$
3. Internal back blow consumption: $0.5 \sim 1.5\text{m}^3/\text{h}$ pressure: 0.24Mpa (adjustable)
4. Operating environment: $-30 \sim 70^\circ\text{C}$, relative humidity: $\leq 95\%$
5. Protection grade: IP56
6. The material of the sampling head of the purging device is $1\text{Cr}18\text{Ni}9\text{Ti}$

Main Features

1. Use the dynamic pressure compensation method of fluid mechanics to truly reflect the pressure value of each measuring point online.
2. The pressure of purging is greater than the pressure measured, which completely solves the blockage and burning of the pressure measuring pipeline under dust-heavy and high-temperature conditions.
3. The voltage regulator is adopted to stabilize the air source provided by the power plant, so as to ensure the stability of the output flow of the flow controller and to achieve long-term reliable operation.
4. No manual purging is required, which greatly reduces the maintenance work and labor intensity of workers in operation.
5. The control box adopts IP56 structure, beautiful in appearance, small in size, easy to maintain and easy to install.
6. The biggest feature of this device is that it adopts advanced and reasonable compensation method with integrated structure, which is suitable for static pressure measurement as well as differential pressure measurement. The distance between the control box and the pressure measuring point has been increased from 4 meters for similar products to 200 meters.

Main structure and principle

1、structure

TKHBC environmental compensation anti-blocking purge device has two main components: constant air flow control box and pressure purge sampling (head) (built-in compensator). (see figure 1)

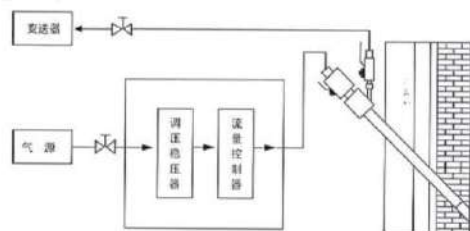

图一

TKHBC环保型补偿式防堵吹扫装置有静压测量装置（见图二）和差压测量装置（见图三）两大类型。
The TKHBC environmental protection compensation type anti-blocking purging device includes static pressure measuring device (see figure 2) and differential pressure measuring device (see figure 3).

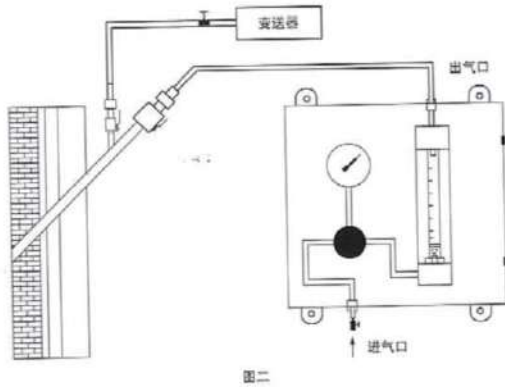

图二

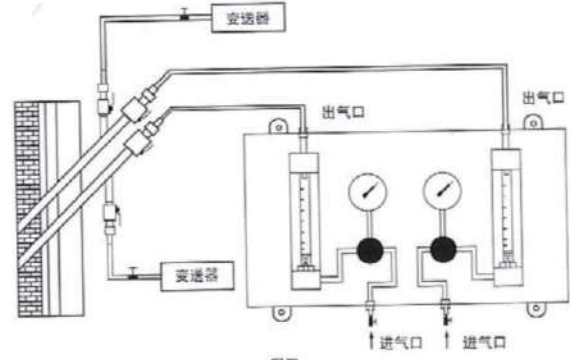

图三

2、原理

该装置的测量原理是利用连续在测点内通风的方法使测点防堵，并利用流体力学的动压补偿方法，消除因反吹扫气流产生的差压，以保证真实准确的测量值，这是HBC补偿式防堵吹扫装置的最大特点。

结构示意图中，（如不加装补偿装置），压力变送器口的取样点A至吹扫口管口B之间，由于气体流动而产生的管内压差为 ΔP ，流动气体的重度为 γ ，该段空气流速为 V ，该管段空气阻力参数为 ζ ，A点压力为 P_A ，B点压力为 P_B 。

$$\text{则 } \Delta P = \gamma \cdot \zeta \cdot V^2 / 2g$$

$$P_A = P_B + \Delta P$$

从公式中可以看出，气体因压力变化会引起气体流量的变化和 ΔP 的改变。在常规的吹扫方法中为保证测量精度只能选用较小的流量，因而很容易引起堵塞和烧毁；如加大流量，变送器又要产生零点偏移，这时只得采取变送器和显示仪表调零的方法，因而引起显示系统混乱，在运行中出现问题也很难校正；调压阀、流量控制器的故障和偏差将直接影响测量的精度，日常维护工作量相当的大。为克服上述弊病，提高测量的精度，在系统中加了压力补偿装置，设补偿压力为 P_B ，补偿后的压力为 P_C （见图四）

$$\text{使 } P_B = -\gamma \cdot \zeta \cdot V^2 / 2g$$

$$P_C = P_B - \Delta P$$

由于 P_C 在图中3-3左侧近似为零，A点压力 P_A 就等于B点压力 P_B 。由于 P_B 随流量而变化， P_A 值不受气源压力，气体流量变化的影响。系统装置中任何元件万一出现故障和损坏不影响系统的测量状态。

2, the principle of

The measuring principle of the device is to use the method of continuous ventilation in the measuring point to prevent the blocking of the measuring point, and use the method of fluid mechanics dynamic pressure compensation to eliminate the cause

The differential pressure generated by the reverse purge airflow can ensure the true and accurate measurement value, which is the biggest feature of the HBC compensation anti-blocking purge device. In the schematic diagram, (if no compensation device is installed), between the sampling point A of the pressure transmitter mouth and the inlet B of the purge mouth pipe is produced due to the gas flow R_{aw} tube differential pressure for ΔP , gas flow severely for γ , this air flow velocity V , the section air resistance parameters for ζ , point A pressure for P_A , pressure point B For the P_B .

$$\Delta P = \gamma \cdot \zeta \cdot V^2 / 2g$$

$$P_A = P_B + \Delta P$$

As can be seen from the formula, the gas by pressure changes will cause the change of gas flow and Δ changes in P . In conventional purging methods for assurance measurements The accuracy can only choose a small flow, so it is easy to cause congestion and burning; If increase the flow, the transmitter and to produce zero offset, then have to take The method of zeroing the transmitter and display instrument causes confusion in the display system and makes it difficult to correct problems in operation. Pressure regulating valves and flow controllers

Faults and deviations will directly affect the measurement accuracy, and the daily maintenance workload is quite large. In order to overcome the above disadvantages and improve the measurement accuracy, a pressure compensation device is added to the system. The compensated pressure is P_B , and the compensated pressure is

$$P_B = -\gamma \cdot \zeta \cdot V^2 / 2g$$

$$P_C = P_B - \Delta P$$

Since P_C is approximately zero on the left side of 3-3 in the figure, the pressure P_A at point A is equal to the pressure P_B at point b. since P_B varies with the flow rate, P_A value is not subject to the air source pressure, gas effects of volume flow changes. The measurement status of the system will not be affected in case of failure or damage of any component in the system.

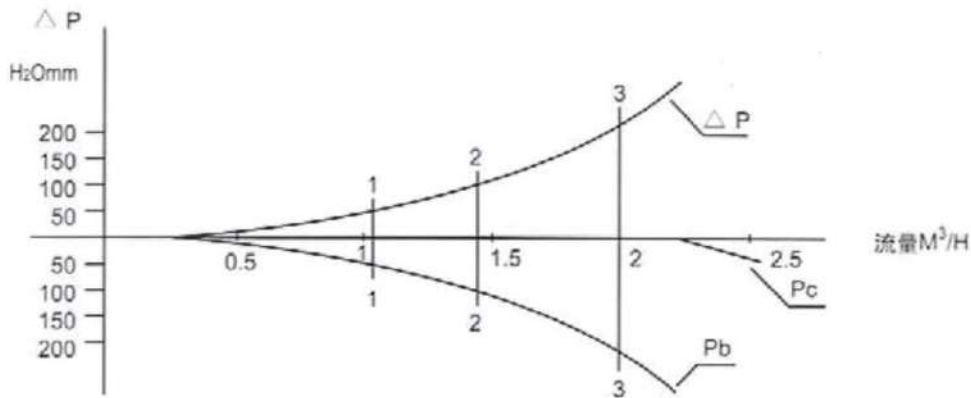

图四

图中1-1直线右侧为不堵塞区，既流速大于7m/s
The right side of line 1-1 in the figure is the non-blocking zone, where the flow rate is greater than 7m/s

图中2-2直线右侧为不烧毁区，既流速9.5m/s
The right side of line 2-2 in the figure is the unburned area, i.e. the flow rate is 9.5m/s

图中3-3直线右侧为不堵塞区，既流速大于7m/s
The right side of line 3-3 in the figure is the non-blocking zone, that is, the flow rate is more than 7m/s

条件：吹扫管Φ25, L=1200, 压PB=0时测试
Condition: pipe purging Φ 25, L = 1200, furnace pressure test PB = 0

型号选型与规格

1、型号：

TKHBC-□-□-□

- a 进口器件
Imported components
- b 国产器件
Domestic device
- A 箱体为不锈钢材质
The box is made of stainless steel
- B 箱体为冷轧板材质
The box body is made of cold-rolled sheet material
- 1 供一个测压点吹气用
For blowing at a pressure point
- 2 供二个测压点吹气用
For blowing at two pressure points
- 3 供三个测压点吹气用
For blowing at three pressure points
- 4 供四个测压点吹气用
For blowing at four pressure points

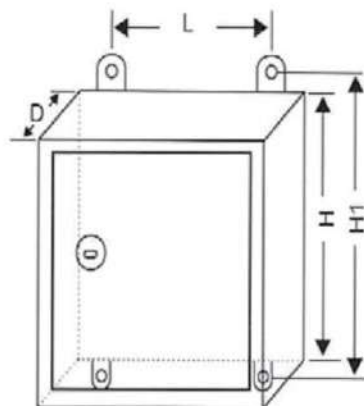

恒气流控制箱外形图
Constant flow control box diagram

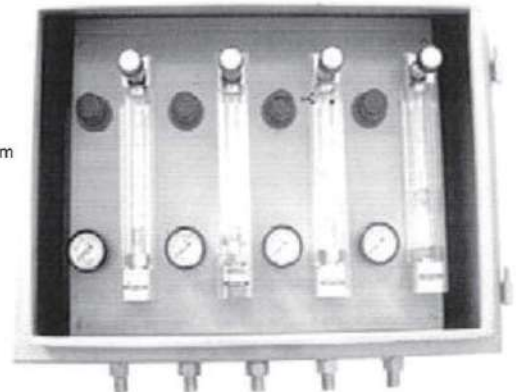

2、控制箱外形尺寸：
Control box dimensions

型号 Model	长L	宽w	H1	深D	备注 Note
TKHBC-1a	250	320	360	210	可根据用户要求定制 Can be customized according to user requirements
TKHBC-2a	320				
TKHBC-3a	400				
TKHBC-4a	480				

型号	长L	宽	H1	深D	备注
TKHBC-1b	220	320	360	200	可根据用户要求定制 Can be customized according to user requirements
TKHBC-2b	300				
TKHBC-3b	380				
TKHBC-4b	460				

3、吹扫取样管外形图
Outline of purged sampling tube

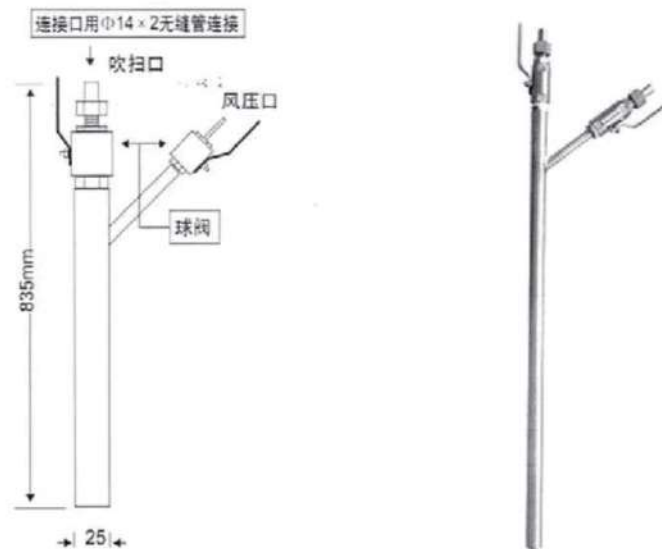

图六

设备的安装与使用
Equipment installation a

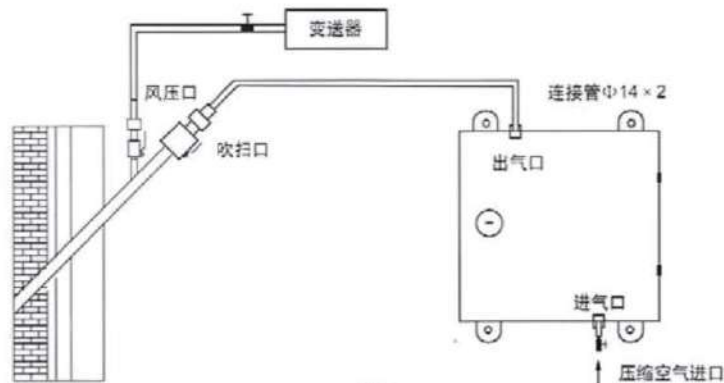

图七

注：1. 吹扫取样器的安装位置均按设计院的要求

Note: 1. The installation location of the purging sampler is in accordance with the requirements of the design institute

2. 吹扫取样器的开孔尺寸为25+1mm或18+1mm

The opening size of the purge sampler is 25+1mm or 18+1mm

3. 管路连接按图一、图七：

The pipeline connection shall be as shown in figure 1 and figure 7;

4. 安装时参阅安装须知。

Refer to installation instructions when installing.

安装须知

- 1、恒气流控制箱采用挂壁式安装并与水平面垂直安装，确保流量控制器正常指示。安装人员不可随意打开恒气流控制箱，更不能随意调节减压器和流量控制器（因箱内的设备在出厂前已调试好）。
- 2、吹扫取样头一般与水平面倾斜角大于30度。炉膛外侧高于炉膛内侧，吹扫取样头前端缩回炉膛内保温层或水冷壁管表面20~50mm。吹扫取样头如用在磨煤机上，如吹扫取样头太长可按实际需要留下合适的长度，多余的锯掉，但锯口必须磨光，无毛刺。
- 3、管路连接应采用Φ14X2的无缝钢管、不锈钢管或金属软管，连接（焊接）前必须用压缩空气将管内的垃圾、尘埃吹扫干净，确保管路内清洁。
- 4、吹扫口、风压口之间的距离不受用户现场安装环境的限制。建议进入锅炉房到吹扫控制箱进气口的压缩空气管需使用≥2寸钢管，确保其到控制箱的空气压力大于0.6MPa。
- 5、管路间有焊接的地方一定要焊好无漏气现象，连接部分加密封垫以确保各接点无漏风现象。
- 6、图中为单路安装示意图，各口编号为进气口、出口。如一个控制箱内配置二路、三路、四路，连接方法和上图一样。

设备的使用

- 1、初次投入使用前须清理管路里的垃圾及焊渣杂质等，确保洁净的气源。
- 2、设备在出厂前均已调试好。建议：初次投运前，关闭调压稳压器，测量炉膛内的风压值，观察其波动情况，此时无吹扫时，不影响其精确的测量。待机组基本正常后，缓慢打开调压稳压器到0.2MPa，调整吹扫流量为1m³/h，吹扫时所测量的值应相同，如有偏差稍微调整吹扫流量。
- 3、注意：恒气流控制箱前总管上须安装气源处理元件（调压过滤器）见图八，且具有自动排水功能，可阻挡管路里的垃圾及水汽进入调压稳压器和转子流量计及补偿器，确保设备长期的正常运行。为防止气源处理元件调压过滤器的堵塞，必须定期清理调压过滤器内内滤网的垃圾。

Installation instructions

1. The constant air flow control box is mounted on the wall and installed vertically with the horizontal plane to ensure the normal indication of the flow controller. The installation personnel shall not open the constant air flow control box at will, nor adjust the pressure reducer and flow controller at will (because the equipment in the box has been debugged before the factory).
2. The purging sampling head generally has an inclination Angle greater than 30° from the horizontal plane. The outer side of the furnace is higher than the inner side of the furnace. The front end of the purging sampling head is retracted into the insulation layer inside the furnace wall or the surface of the water-cooled wall tube for 20-50mm. If the purge sampling head is used in a coal mill, if the purge sampling head is too long, the appropriate length can be left according to the actual needs of the excess saw off, but the saw must be polished without burr.
3. 14 x2 connection should use Φ seamless steel pipe, stainless steel pipe or metal hose, connection (welding) must use compressed air to tube before purging of garbage, dust clean, ensure clean in the pipeline.
4. The distance between the purge port and the air pressure port is not limited by the user's on-site installation environment. It is recommended that the compressed air pipe from the boiler room to the air inlet of the purge control box should use ≥2" steel pipe to ensure that the air pressure to the control box is greater than 0.6mpa.
5. If there is any welding between the pipelines, there must be no leakage, and gasket should be added to the connection part to ensure that there is no leakage at the joints.
6. The diagram is a schematic diagram of single-way installation, and each port is numbered as air inlet and air outlet. If a control box is equipped with two, three and four channels, the connection method is the same as above.

Use Equipment

1. Clean the garbage and welding slag and impurities in the pipeline before the initial operation to ensure a clean gas source.
2. The equipment has been debugged before delivery. Suggestion: before the initial operation, turn off the voltage regulator, measure the wind pressure value in the furnace, observe its fluctuation, when there is no purging, it will not affect the accurate measurement. When the unit is basically normal, slowly open the regulator to 0.2mpa and adjust the purge flow to 1m³/h. The measured value during the purge should be the same. If there is any deviation, slightly adjust the purge flow.
3. Note: the air source processing element (pressure regulating filter) shall be installed on the main pipe before the constant air flow control box, as shown in figure 8, and it shall have the automatic drainage function, which can prevent the garbage and water vapor in the pipeline from entering the pressure regulating regulator, rotor flowmeter and compensator, so as to ensure the long-term normal operation of the equipment. In order to prevent the blocking of the pressure regulating filter of the air source treatment element, the garbage in the filter net must be cleaned regularly.

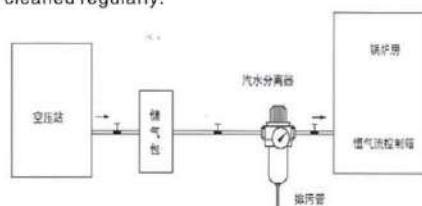

常见故障分析 Common fault analysis

故障表现 Fault indication	故障分析 Failure analysis	解决方法 The solution
变送器无输出 The transmitter has no output	变送器管路堵塞 The transmitter line is blocked	清除管路 Remove the pipe
空气耗气量增大 Air consumption increases	吹扫流量过大 Excessive purge flow	重新调整 To readjust
测量值与实际值不符 The measured value is out of line with the actual value	吹扫管路堵塞及变送器管路漏气 Purge pipeline blockage and transmitter pipeline leakage	检查 check
同一层面各点测量值不同 Different values are measured at the same level	关闭吹扫流量时测量值不变属正常 It is normal for the measured value to remain unchanged when the purge flow is turned off	查找锅炉及变送器原因 Find out the cause of boiler and transmitter
减压阀压力不稳定 The pressure of the relief valve is unstable	减压阀内密封性差及垃圾 Pressure relief valve poor sealing and garbage	清洗减压阀 Clean the relief valve
风压测量值增大 The wind pressure measurement increased	炉膛内吹扫管路堵塞，吹扫空气直接到变送器，已损坏变送器 The purge line in the furnace is blocked, and the purge air is directly to the transmitter, which has damaged the transmitter	清除炉膛内垃圾 Remove rubbish from the furnace

TKPSA-T 型气源净化装置

TKPSA-T air source purification unit

概述

1、气源净化装置在电厂中大量使用,压缩空气是否干燥会影响气动控制系统的安全稳定运行,因压缩空气带水而导致机组故障甚至停机时有发生。压缩空气虽然经干燥处理,但仍带有一定的水分(特别南方电厂水分更多)。而这部分水分在不同的季节随时间而积累呈复杂不确定关系。因此水分积累的结果是:一方面影响用气设备的安全正常的工作,并加速其损坏;另一方面严重腐蚀储气、压缩机等设备,造成恶性循环。

压缩空气带水是电厂普遍存在的问题,目前一般采用手动疏水阀人工排放或利用机械式疏水阀进行疏水。这两种疏水方式存在以下缺点:

- (1) 由于供/用汽点多而面广,对疏水阀进行人工巡检及手动排水阀耗时费力,且现场难以判断是否疏水干净。
- (2) 机械式疏水阀偏差大、可靠性差。
- (3) 机械式疏水阀结构复杂易出现故障并难以修理。
- (4) 不具备在线监视功能,无法在集控室内实现在线监视,更无法与计算机通讯。

TKPSA-T 型气源分配控制管理系统

主要性能特点

根据上述情况研发的 PSA-T 型气源分配控制管理系统。经数年在电厂使用与发展已进入第三代可编程智能型产品,该控制产品体积小,稳定性可靠,可实现在线安装该系统。能有效解决仪用压缩空气系统中发生气动执行机构或控制单元被水污染的难题。主要特点如下:

- (1) TKPSA-T 型产品核心部分采用 SCHNEIDER 系列 PLC。通过上位机和控制程序完成控制组态工作。电磁阀采用 SMC 公司或其它进口产品。
- (2) TKPSA-T 型产品具有良好的人机工作界面。根据过滤器使用情况。具有现场中断测试功能、软中断测试功能,软件设计预留局部网络功能。
- (3) TKPSA-T 型产品特别加强了安全可靠设计能够在恶劣工况环境下可靠运行。防护等级 Ip65。软件设计具有在线自诊断(包括失电报警)2软件控制采用模糊控制(Fuzzy Control)策略;一方面控制出水率;另一方面控制各点排水时间顺序,确保排水对气源系统压力的扰动最小。从而保障气动执行机构和/或控制单元的安全稳定可靠。
- (4) TKPSA-T 型产品根据用途的不同主要是控制排水点数量的大小其产品分为单回路、双回路。
- (5) TKPSA-T 型产品允许通过 RS-232 总线进行网络连接。可连接多达 31 台 PSA-T 型控制器。每台 TKPSA-T 均构成网络上的一个控制站。极大的方便了用户设备管理。

技术指标

- 供电电源:电压:220 AC \pm 10% 频率:50HZ
环境温度: -20~60℃
输入、输出气源压力: \leq 9.9kgf/cm²
过滤器输出流量: 8000L/min
输入、输出气源管路: Φ 25、 Φ 35 (可根据设计需要定)
过滤精度: 过滤精度达到 5 μ m, 除水效率不低于 96%
二路开关量输出: 控制排污电磁阀

安装及保养

TKPSA-T 型智能气源净化装置可根据现场条件,水平放置在气源管路的旁边,进气及出气管(在箱体侧面)采用焊接式活络接头连接(也可根据用户采用金属软管),根据自身气源的质量定期更换滤芯,确保气源畅通无阻,保障全厂的气动设备正常运行。

安装时只需放一路 220V 交流电源接入控制箱内电源开关,下端内部控制接线在出厂时均已接好,不需用户连接;然后连接好进气及出气管路,打开电源,设置好控制参数,即可投入使用。

注:在开机前由于现场工作环境恶劣,气源中含有大量杂质,故先打通 Dn1, 关闭 DN2、DN3, 在 Dn1 打通状态即为气源直通状态,待气源正常后关闭 Dn1, 打通 DN2、DN3, 即为气源净化状态,设备处于正常使用状态。

overview

1. Air source purification device is widely used in power plants. Whether the compressed air is dry or not will affect the safe and stable operation of the pneumatic control system, because of the compressed air With water and lead to unit failure or even stop from time to time. Although the compressed air is dried, it still contains some moisture (especially in southern power plants) And this part of water in different seasons with the accumulation of time shows a complex uncertainty relationship. Therefore, the result of water accumulation is: on the one hand, it affects the gasequipment The safety of normal operation and acceleration of its damage; On the other hand, serious corrosion of gas storage, compressor and other equipment, resulting in a vicious cycle. Compressed air with water is a common problem in power plants. At present, manual steam trap is usually used to discharge water manually or mechanically.

These two hydrophobic methods have the following disadvantages:

- (1) due to the large number of supply/use steam points and wide area, manual inspection and manual drainage valve of the trap is time-consuming and laborious, and it is difficult to judge whether the trap is clean on site.
- (2) large deviation and poor reliability of mechanical steam trap.
- (3) mechanical steam trap is complicated in structure, easy to break down and difficult to repair.
- (4) it does not have the online monitoring function, and cannot realize online monitoring in the central control room, let alone communicate with the computer.

TKPSA-T air source distribution control management system main performance characteristics

The psa-t type air source distribution control management system was developed according to the above situation. After years of use and development in power plants, it has entered into the third generation of programmable intelligent products.

It can effectively solve the problem of water pollution of pneumatic actuator or control unit in instrument compressed air system. The main features are as follows:

- (1) the core part of tkpsa-t product adopts SCHNEIDER series PLC. Through the upper computer and control program to complete the control configuration work. Solenoid valve using SMC company or other imported products.
- (2) tkpsa-t product has a good man-machine interface. Depending on filter usage. With field interrupt test function, soft interrupt test function, software design reserved local network function.
- (3) the tkpsa-t product is specially designed to be safe and reliable for reliable operation under severe working conditions. Protection class Ip65.
- (4) tkpsa-t product is specially designed to be safe and reliable for reliable operation under severe working conditions. Protection class Ip65.
- (5) Fuzzy Control is adopted for software Control. Strategy: On the one hand, water yield is controlled; On the other hand, the time sequence of each point drainage is controlled to ensure the least disturbance of drainage to the pressure of the air source system.
- (6) To ensure the safety and stability of pneumatic actuators and/or control units.
- (7) tkpsa-t products are divided into single loop and double loop according to the different purposes, mainly to control the number of drainage points.
- (8) the tkpsa-t product allows network connectivity through the rs-232 bus. Up to 31 psa-t controllers can be connected. Each tkpsa-t constitutes a control station on the network. Greatly facilitate the user device management.

Technical indicators

- Power supply: voltage: 220ac \pm 10% frequency: 50HZ
Ambient temperature: -20 ~ 60℃
Input and output air source pressure: \leq 9.9kgf/cm²
Filter output flow: 8000L/min
Input, output, air line: Φ 25, 35 (can be) according to the needs of design
 Φ filtration precision: filtration precision reached 5 microns, in addition to water efficiency of no less than 96%
Two-way switch output: control discharge solenoid valve

Installation and maintenance

TKPSA-T type intelligent air source purification device can be placed horizontally next to the air source pipeline according to the field conditions, and the inlet and outlet pipes (on the side of the box body) are connected with welded adjustable joints (or with metal hoses according to the user), according to the self

The quality of the body air source is regularly replaced with the filter element to ensure the air source is unimpeded and to ensure the normal operation of the pneumatic equipment of the whole plant.

During installation, only one 220V ac power supply needs to be connected to the power switch in the control box. The internal control wiring at the lower end has been connected at the factory, and no user connection is required. Then connect the inlet and outlet pipelines, turn on the power supply, set the control parameters, Ready for use.

Note: before starting the machine, due to the bad working environment on site, there are a lot of impurities in the gas source, so first get through the Dn1, close the DN2 and DN3, in the Dn1 get through state is the gas source through state, after the gas source is normal, close the Dn1, get through the DN2 and DN3, That is, the air source is purified and the equipment is in normal use.

安装示意图如图 4.1 所示，系统原理图 4.2 所示。

The installation diagram is shown in figure 4.1 and the system principle is shown in figure 4.2.



图 4.1 TKPSA-T 型智能气源净化装置安装示意图

Figure 4.1 installation diagram of tkpsa-t type intelligent air source purification device

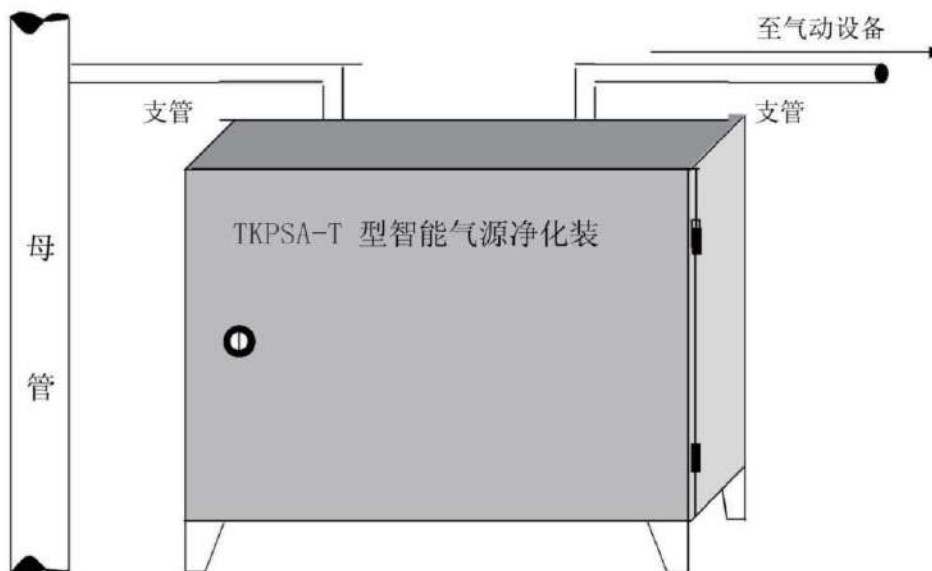

图 4.2TKPSA-T 型净化模式单元图
Figure 4.2 unit diagram of tkpsa-t type purification mode

电厂气源净化点典型选择一览表
List of typical selection of power plant gas source purification points

序号	内容content	安装模式 installation mode	备注 note
1	杂用空压机气水分离器 Miscellaneous air compressor gas-water separator	C	
2	仪用空压机气水分离器 Instrument with air compressor gas water separator	C	
3	仪用空气储气罐 Instrument air storage tank	C	
4	杂用空气储气罐 Miscellaneous air storage tank	C	
5	仪用空气母管 Instrument air master tube	C	
6	杂用空气母管 Miscellaneous air master tube	C	
7	空气过滤器 Air filter	C	
8	化水车间空压机气水分离器 Air compressor air water separator in water melting workshop	C	
9	化水车间用压缩储气罐 Compressed gas storage tank for chemical water plant	C	
10	化水车间各气动隔膜阀用气群 Pneumatic diaphragm valves in the water workshop gas group	A	
11	汽机房运行层仪用压缩空气母管 Compressed air master tube for turbine room operating meter	C	
12	汽机房中间层仪用压缩空气母管 Compressed air master tube for steam engine room interstratometer	C	
13	汽机房 0m 层仪用压空气母管 Pressurized air master tube for 0m meter in steam turbine room	C	
14	汽机抽气逆止阀用气群母管 The steam engine exhaust reverse valve USES the gas group master tube	A	
15	汽机厂供高、低加疏水控制用气群母管 Steam turbine plant for high, low and hydrophobic control of the gas group master tube	A	
16	锅炉各台磨煤机手动气群 Boiler coal mill hand-operated air group	A	
17	锅炉工业电视检探头用气点 Gas point for industrial television inspection probe of boiler	B	
18	锅炉氧化锆探头用气点 Gas point for zirconia probe of boiler	B	
19	锅炉仪用空气母管 Air master tube for boiler instrument	C	
20	锅炉 A 角用气群母管 Boiler A - Angle gas group parent tube	A	
21	锅炉 B 角用气群母管 Boiler B Angle gas group master tube	A	
22	锅炉 C 角用气群母管 Boiler C Angle gas group master tube	A	
23	锅炉 D 角用气群母管 Boiler D - Angle gas group master tube	A	

注：本表是 125MW-350MW 机组气源点的典型选取，其余类型机组可酌情参考增减。
Note: this table is a typical selection of the gas source points of 125MW-350MW units. Other types of units may be added or removed as appropriate.

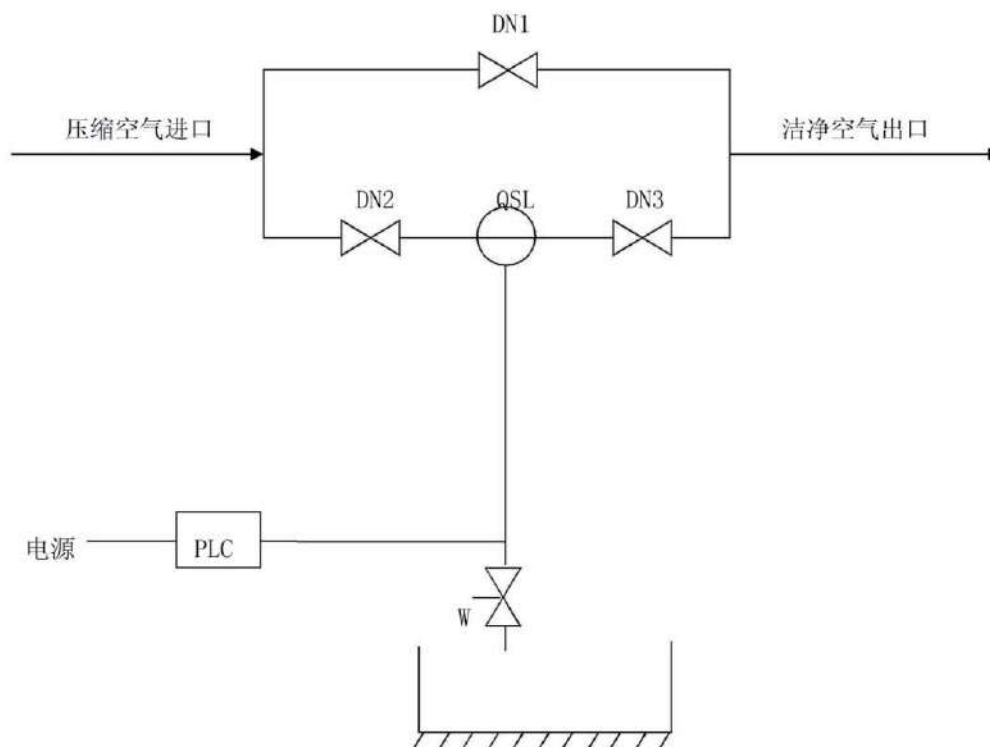
600MW 机组热控气源选点表
 600MW unit thermal control gas source selection table

序号	内容content	备注note
1	前墙用气点 (燃烧器、点火油设备、二三次风门、冷却风) Air point for front wall (burner, ignition oil equipment, secondary and tertiary damper, cooling air)	
2	后墙用气点 (燃烧器、点火油设备、二三次风门、冷却风) Air point for rear wall (burner, ignition oil equipment, secondary and tertiary damper, cooling air)	
3	空预器 A 烟气压力等用气点 Air preheater A gas pressure and other gas points	
4	电除 A、B 用气点 Electricity divides the gas points of A and B	
5	空预器 B 烟气压力等用气点 Air preheater B gas pressure and other gas points	
6	电除 C、D 用气点 Electricity divides C, D use gas point	
7	引风机 A、B 用气点 The air points of the induced draught fan A and B	
8	磨煤机 A、B、C、D、E、F 用气点 Coal mill A, B, C, D, E, F gas point	每台磨煤机装一台控制器 Each coal mill is fitted with a controller
9	A、B 侧炉膛火焰工业电视用气点 A, B side furnace flame industrial television gas point	
10	A、B 空预器密封间隙测量用气点 A, B air preheater sealing gap measurement gas point	
11	除氧器、辅汽联箱压力调节阀用气点 Deaerator, auxiliary steam header pressure control valve gas point	
12	高压缸 A、B 侧疏水阀用气点 High pressure cylinder A, B side trap gas point	
13	中压缸、高加疏水用气点 Medium pressure cylinder, high and hydrophobic gas point	
14	二、三、四段抽汽逆止门等疏水用气点 The second, third and fourth sections of the extraction steam back door, such as steam trap gas point	
15	五、六段抽汽逆止门疏水门用气点 Five, six sections of steam extraction reverse stop gate steam trap point	
16	真空泵、凝汽器水位调节阀等用气点 Vacuum pump, condenser water level control valve and other gas point	
17	低压缸喷水调节阀等用气点 Low pressure cylinder water control valve and other gas point	
18	凝汽器除氧器水位调节阀用气点 Condenser deaerator water level control valve gas point	
19	辅助汽源站、轴封主汽站调节阀用气点 Auxiliary steam source station, shaft seal main steam station control valve gas point	
20	1#高加、5#低加系统调节阀用气点 1# high addition, 5# low addition system control valve gas point	
21	2#高加、6#低加系统调节阀用气点 2# high addition, 6# low addition system control valve gas point	
22	7#、8#低加调节阀用气点 7#, 8# low valve gas point	

注：1、压缩空气净化装置进出口接管一律用直径 32×2.5
 2、各用气点接管一律用直径 14×1
 3、所有设备装置选用 PSA-TDN25
 4、净化模式一般采用 A 模式，也可以按设计图采用其他模式。

Note: 1. The diameter of inlet and outlet connection of compressed air purification device shall be 32 × 2.5
 2. The diameter of all gas points shall be 14 × 1
 3. PSA-TDN25 shall be used for all equipment
 4. The purification mode generally adopts mode A, or other modes can be adopted according to the design drawing.

控制单元操作说明

一、概述

本控制仪主要采用西门子 S7-200 系列 PLC、西门子 TD400C 文本, Siemens 的 PLC 显示器等国外知名品牌, 并融入我们多年制造的经验, 精工设计而成的专用控制仪。

二、技术规格

- 2.1、供电电源: 交流电压 220VAC ± 10%
- 2.2、消耗功率: ≤ 50W;
- 2.3、工作环境: 温度: -40~65℃; 湿度: ≤ 85%。

三、操作说明

请用户仔细阅读本手册, 以正确使用该控制仪, 正确接上 220V 电源, 并检查确定无误后送电。

接电后显示运行画面:

3.1. 运行画面 (主画面)

Running screen (main screen)



Control unit operation instructions

1、overview.

This control instrument mainly adopts Siemens s7-200 series PLC, Siemens TD400C text, Siemens PLC display and other well-known foreign brands, and integrates our years of manufacturing experience, seiji design into the special control instrument.

2、Technical specifications

- 2.1 power supply: ac voltage 220VAC ± 10%
- 2.2 consumed power: ≤ 50W;
- 2.3 working environment: temperature: -40 ~ 65℃; Humidity: ≤ 85%.

3、Operation instructions

Please read this manual carefully, so as to use the controller correctly, connect the 220V power supply correctly, and send the power after checking. Display operation screen after power connection:

3.2. 通道选择画面

Channel selection screen





3.3 时间设定画面

Time setting screen





4 参数设定

4.1 通道选择

设定参数时, 在主画面, 然后按下一页 , 进入通道选择画面。如选择 1# 通道, 直接按一下显示器上的左键 , 后面的状态灯  变成黑色, 再按一次该键则取消选择。2# 通道选择同理。



(注意: 同时只能选择 1 个通道, 不可两个通道同时开启)

4.2 时间设定在通道设定好后, 在通道选择页面按下一页 , 进入时间设定画面, 先按 , 如图标进入吹扫时间设置, 时间是由 4 位数组成, 通过上、下键调整个位数数值, 调整好后再按左键把光标移到十位数,





parameter setting

4.1 channel selection

When setting parameters, in the main screen, and then press the next page to enter the channel selection screen . If you select channel 1#, press the left button on the display directly . The status light behind turns black . The same goes for channel 2.

(note: only one channel can be selected at the same time, not two channels can be opened at the same time)

4.2 time setting after the channel is set, press the next page on the channel selection page to enter the time setting screen , press first, such as the icon to enter the purge time setting, the time is composed of four digits , adjust the single digit value through the up and down keys, press the left button to move the cursor to the ten digits after the adjustment.



再通过上下键调整十位数数值，如果用到百位数个千位数以此类推。全部设定好后按 **ENT**，光标进入间隔时长设定，同理设置间隔时长。设定好后按下一页进入主画面。

5. 正常操作



在通道和时间都设置好后，在主画面下

And then by the up and down keys to adjust the number of ten digits, if you use the hundreds of thousands of digits and so on. **ENT** Press after all Settings are set, and the cursor enters the interval duration setting. Similarly, set the interval duration. Click the next page to enter the main screen.

5. Normal operation

After the channel and time are set, under the main screen



按左键 ，设备启动，按右键 ，设备停止。

（注意：如果通道和时间设定好后，设备再次开启时，如果通道和时间都不用修改，可直接在主画面按启动按钮启动设备。） 出厂设置：导通时间为 5 秒，间隔周期为 120 分钟。

Press the left button to start the device  , press the right button to stop the device 

(note: if the channel and time are set, and the device is opened again, if the channel and time need not be modified, the device can be started directly by pressing the start button in the main screen.) Factory setting: conduction time is 5 seconds, interval is 120 minutes.

吹扫 (装置) 流量计 Purge (device) flowmeter

概述

该产品是采用金属管浮子或玻璃转子流量计与恒流阀配合，构成流量吹扫装置，实现流量测量并确保流量恒定输出。

由于浮子流量计安全可靠，测量精确稳定的特点，因此，该系列吹气装置对于入口或出口压力变化时，能够确保流量恒定输出，可以广泛应用于石油炼制、化工、乙烯、化肥、钢铁、化纤纺织等行业变送器的吹扫、差压法液位测量等过程控制中。

该系列产品的设计结构完全满足工业控制的要求，安装适用条件完全符合仪表测量技术的要求。



工作原理

根据测量结构示意图(以恒定入口压力为例)可以看出：
弹性膜片受到向上的作用力为： $P_2A + P_1a$ (1)
弹性膜片受到向上的作用力为： $P_3A + P_2a + F$ (2)

在压力处于平衡状态时，即：(1)=(2)时， $P_2A + P_1a = P_3A + P_2a + F$ (3)

作为压力调节器膜片的差压 $P_2 - P_3$ ，我们可以得到以下的等式： $P_2 - P_3 = F/A - a/A(P_1 - P_2)$ (4)

由于 $a < A$ ，所以 $a/A(P_1 - P_2)$ 可以忽略不计，由于 F 和 A 都是恒定值，所以： $C(\text{恒定值}) = P_2 - P_3$

当测量介质是不可以压缩的液体时，RE压力调节器可以适用出口压力变化。

对于(4)式中，由于 P_1 是恒定的， P_3 是变化的，因此， P_3 变为： $P_3 + \Delta P$ P_2 变为： $P_2 + \Delta P$ ，

所以： $C(\text{恒定值}) = P_2 - P_3$

特点 characteristics

- ◆ 单路，双路，多路形式(可选)
single way, double way, multiple way (optional)
- ◆ 单表安装，面板安装，柜式安装(可选)
single table installation, panel installation, cabinet installation (optional)
- ◆ 1/4" NPT，卡套，螺纹，法兰连接(可选)
1/4" NPT, sleeve, thread, flange connection (optional)
- ◆ 6mm, 8mm, 10mm, 15mm, 25mm管路
6mm, 8mm, 10mm, 15mm, 25mm pipeline
- ◆ 开关信号输出，4-20mA信号输出(可选)
switch signal output, 4-20ma signal output (optional)
- ◆ 金属结构，简单，坚固，美观
metal structure, simple, strong, beautiful
- ◆ 可以测量过程温度低于200℃
the process temperature can be measured below 200℃
- ◆ 可以测量过程压力低于6.4MPa
the process pressure can be measured below 6.4mpa
- ◆ 流量，压力(可选)现场指示
flow, pressure (optional) field indication
- ◆ 采用本公司LZ系列浮子流量计
use the company's LZ series float flowmeter
- ◆ 可选配精密微型针型阀，方便，灵活，便于现场流量调节
optional precision miniature needle valve, convenient, flexible, easy to adjust the field flow

An overview

The product is a metal tube float or glass rotor flowmeter with the constant flow valve, constitute a flow purge device, to achieve the flow measurement and ensure the flow constant output.

Due to safe and reliable, float flowmeter measurement precision and stable characteristics, therefore, the series of blower for entry or exit pressure changes, to ensure the constant flow output, can be widely used in petroleum refining, chemical industry, ethylene, chemical fertilizer, steel, chemical fiber textile industry such as purging of transmitter, differential pressure method of level measurement and other process control.

The design structure of this series of products fully meets the requirements of industrial control, and the installation conditions fully meet the requirements of instrument measurement technology.

The working principle of

According to the schematic diagram of measurement structure (taking constant inlet pressure as an example), it can be seen that:

The upward force exerted on the elastic diaphragm is $P_2A + P_1a$. . . (1)

The upward force on the elastic diaphragm is: $P_3A + P_2a + F$. . . (2)

When the pressure is in equilibrium, namely: (1)=(2), $P_2A + P_1a = P_3A + P_2a + F$. . . (3)

As the differential pressure of the pressure regulator diaphragm $p_2 - p_3$, we can obtain the following equation: $p_2 - p_3 = F/a - A/(p_1 - p_2)$. . . (4)

Since a is less than A , $a/A(p_1 - p_2)$ can be ignored. Since F and A are constant values, $C(\text{constant value}) = p_2 - p_3$

When the measuring medium is an incompressible liquid, the RE pressure regulator can be applied to outlet pressure changes.

In equation (4), since P_1 is constant and P_3 is changing, P_3 becomes: $P_3 + \Delta P$ P_2 becomes: $P_2 + \Delta P$,

So: $C(\text{constant value}) = P_2 - P_3$



图2 测量结构示意图

技术参数 Technical parameters

表1

仪表型号 Instrument model	TKLZB (配用玻璃管浮子流量计) flowmeter with glass tube float)	TKLZZ (配用金属管浮子流量计) With metal tube float flowmeter
测量范围(100%值) Measurement range (100% value)		
水:20℃ Water: 20℃	3~1001 /h	25~40001/h
空气:0.1 MPa, 20℃ Air: 0.1 MPa, 20℃	50~34001/h	0.7~80m3/h
量程比 Range than	10:1	10:1
准确度等级 Accuracy grade	4	1.5
流量刻度 The flow calibration	实际流量刻度 Actual flow scale	实际流量刻度 Actual flow scale
介质压力 Medium pressure	最大 biggest 1.0MPa	最大 biggest 6.4MPa (特殊要求可增加) Special requirements may be added)
介质温度 Medium temperature	-20℃~100℃	-20℃~200℃
环境温度 The environment temperature	-20℃~60℃	-20℃~60℃
接触介质材质 Contact medium material	304、316	304, 316
外壳 The shell	塑料 Plastic、PVC	铸铝、环氧树脂喷涂 Cast aluminum, epoxy resin spraying
过程连接 Process connection		
卡套 Card set	Φ6mm, Φ8mm, Φ10mm	Φ6mm, Φ8mm, Φ10mm
螺纹 The screw thread	1/4"NPT, 1/2"NPT	1/4"NPT, 1/2"NPT
法兰 The flange	1/2"ANSI 150Ib, DIN2501, HG, GB	1/2"ANSI 150Ib, DIN2501, HG, GB
特殊 special	根据用户要求 According to user requirements	根据用户要求 According to user requirements

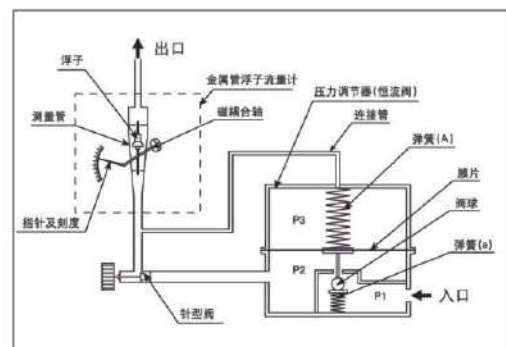
流量表

标校条件:水:20℃ 空气:20℃ 0.1013MPa (abs), 实际介质量程将根据条件进行计算转换。

Flow meter

Calibration conditions: water :20℃; air :20℃; 0.1013MPa (abs); actual medium range will be calculated and converted according to the conditions.

配用玻璃管浮子流量计

表2

Equipped with glass tube float flowmeter

锥管号 Taper pipe	阀门芯轴直径(mm) Valve spindle diameter	水 Water l/h (100%)	空气 Air l/h (100%)	压力损失 pressure loss(kPa)
QF005	1.0	-	50	1.2
QF010	1.0	3	100	1.4
QF015	1.0	5	150	1.5
QF040	2.5	10	400	1.8
QF080	2.5	25	800	3.5
QF125	2.5	40	1250	6.5
QF200	2.5	60	2000	13.0
QF300	2.5	80	2500	23.5
QF340	4.5	100	3400	40.0

配用金属管浮子流量计 With metal tube float flowmeter

表3

口径 Cal	锥管号 Taper pipe	水 Water l/h (100%)	空气 Air m ³ /h (100%)	压力损失 pressure loss(kPa)
15	QF15.1	25	0.7	1.5
	QF15.2	40	1.0	1.5
	QF15.3	60	1.5	1.5
	QF15.4	100	2.2	1.5
	QF15.5	160	3.6	1.5
	QF15.6	250	5.5	3.0
	QF15.7	400	10	3.0
	QF15.8	630	14	3.5
25	QF25.0	630	14	1.5
	QF25.1	1000	22	1.5
	QF25.2	1600	35	1.5
	QF25.3	2500	50	3.0
	QF25.4	4000	80	3.5

◆ 配有微小流量金属管浮子流量计流量表同表1

The flowmeter meter with micro-flow metal

◆ 配用的RE和RA恒流阀

tube float is shown in table 1RE and RA constant current valves

表4

恒流阀型号Constant current valve model	RE	RA
应用条件Application conditions	恒定入口压力变化P1 Constant inlet pressure change P1	恒定入口压力变化P2 Constant inlet pressure change P2
介质状态State media	液体或气体Liquid or gas	液体或气体Liquid or gas
介质温度Medium temperature		
标准standard	80℃	80℃
特殊special	150℃	150℃
介质压力Medium pressure		
标准standard	1.0MPa	1.0MPa
特殊special	6.4MPa(根据需要可增加) (to be increased as required)	6.4MPa(根据需要可增加) (to be increased as required)
可控压力范围Controlled pressure range	0.02~0.5MPa	
压差Differential pressure	0.02~0.045MPa	0.02~0.045MPa
控制精度Control precision	4.0%(选用玻璃管浮子流量计) choose glass tube float flowmeter 1.5%(选用金属管浮子流量计) 1.5%(use metal tube float flowmeter)	4.0%(选用玻璃管浮子流量计) choose glass tube float flowmeter 1.5%(选用金属管浮子流量计) 1.5%(use metal tube float flowmeter)
最小工作压力Minimum operating pressure	0.005MPa(见曲线表) see curve table	0.005MPa(见曲线表) see curve table
最小工作压力下压差Differential pressure under minimum operating pressure	0.002 ~ 0.004MPa(见曲线表) see curve table	0.002 ~ 0.004MPa(见曲线表) see curve table

RE入口压力变化恒流阀特性曲线

RE inlet pressure change constant current valve characteristic curve

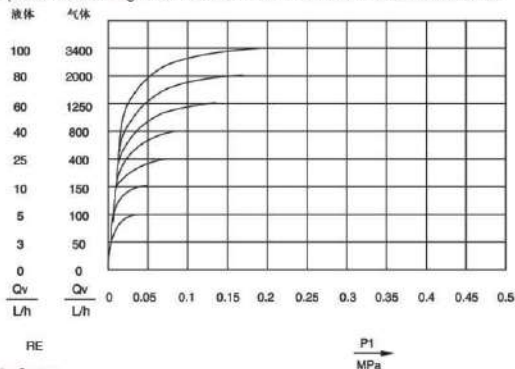

Ra出口压力变化恒流阀特性曲线

Characteristic curve of constant current valve with Ra outlet pressure variation

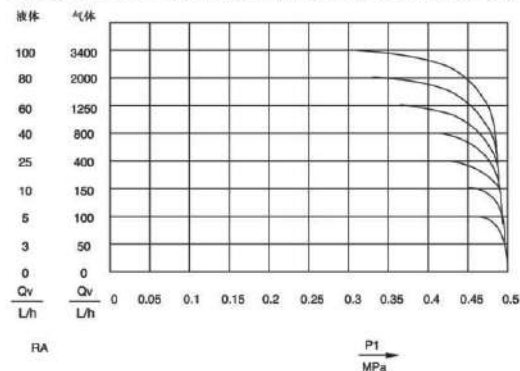

典型应用

◆ 配在供气压力变化条件下的典型应用

如右图所示：将主管道气源提供的气体，根据需要可分成多支路，若关闭或调整其中的几个支路气体流量时，将引起主管道的供气压力发生变化，安装于支路上的单路吹扫装置，可以准确测量流量并保持其输出流量稳定。

推荐产品型号：

LZB-()DK/RE 装有玻璃管流量计吹扫装置

LZZ-()/RE 装有金属管流量计吹扫装置

As shown in the figure on the right: the gas supplied by the gas source of the main pipeline can be divided into multiple branches as required. If the gas flow of several branches is closed or adjusted, the gas supply pressure of the main pipeline will change.

Recommended product model:

LZB-()DK/RE is equipped with glass tube flowmeter purging device

LZZ-()/RE is equipped with metal tube flowmeter purging device

Typical applications

Typical application of the distribution under the condition of changing air supply pressure



图3

◆在出口压力发生变化下的典型应用-液位测量

Typical application under outlet pressure change - liquid level measurement

如右图所示：从A端恒定流量的气体时，气体将排出插入液体管道内介质并形成稳定气泡，此时A、B间管内的压力与B端口液体压力相等。

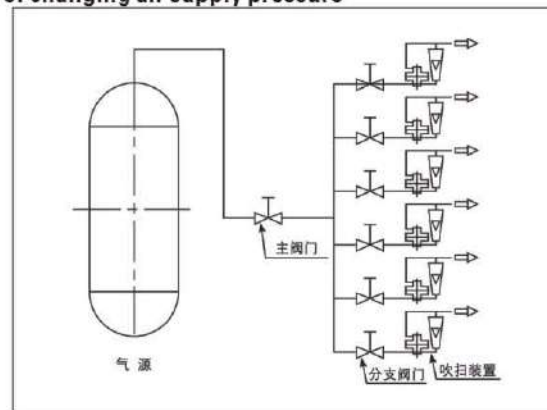
如果B处的压力为 P_1 ，大气压力为 P_0

则 $P_1 - P_0 = \Delta P$ ，同时

$P_1 = \rho h + P_0$ 则

$P_1 - P_0 = \rho h = \Delta P$

因此，在已知介质密度的条件下，利用差压变送器或压力计测量出 ΔP ，即可测量出液体液位 h 。

推荐产品型号：

LZB-()DK/RA 装有玻璃管流量计吹扫装置

LZZ-()/RA 装有金属管流量计吹扫装置

As shown in the figure on the right: when the gas with constant flow from m end A, the gas will discharge the medium inserted into the liquid pipe and form stable bubbles. At this point, the pressure in the pipe between A and B is equal to the liquid pressure at end B.

If the pressure at B is P_1 , the atmospheric pressure is P_0

$P_1 - P_0 = \Delta P$,

$P_1 = \rho h + P_0$

$P_1 - P_0 = \rho h = \Delta P$

Therefore, under the condition of known medium density, using differential pressure transmitter or manometer to measure ΔP , the liquid level h can be measured.

Recommended product model:

LZB-()DK/RA is equipped with glass tube flowmeter purging device

LZZ-()/RA is equipped with metal tube flowmeter purging device

◆在出口压力发生变化下的典型应用-密度测量

Typical application under outlet pressure change - density measurement

如右图所示：如果已知被测介质液位 h_1 与参考介质液位 h_2 ，已知参考介质密度 ρ_2 ，利用差压变送器测量的差压，就可以测量出被测介质密度 ρ_1 。

推荐产品型号：

LZB-()DK/RA 装有玻璃管流量计吹扫装置

LZZ-()/RA 装有金属管流量计吹扫装置

As shown in the figure on the right: if the liquid level h_1 of the medium under test is known and the liquid level of the reference medium is known h_2 , given the density of the reference medium is ρ_2 , the differential pressure measured by using the differential pressure transmitter,

You can measure the density of the medium being measured.

Recommended product model:

LZB-()DK/RA is equipped with glass tube flowmeter purging device

LZZ-()/RA is equipped with metal tube flowmeter purging device

◆在差压变送器测量流量时的典型应用

Typical applications in differential pressure transmitters for flow measurement

当用孔板与差压变送器测量腐蚀性或含有固体颗粒的液体或含有粉尘的气体流量时，引压毛细管就有被堵塞的可能。采用双回路吹气装置吹洗二个压力孔，就可以确保液体颗粒或粉尘不会堵塞压力孔或引压管。

推荐产品型号：

LZB-()DK/RE 装有玻璃管流量计吹扫装置

LZZ-()/RE 装有金属管流量计吹扫装置

When the orifice and differential pressure transmitters are used to measure the flow of corrosive or solid or dust-containing liquids, the pressure capillaries may become clogged. Two pressure holes can be cleaned by double circuit air blower to ensure that liquid and solid particles or dust will not clog the pressure holes or pressure pipework.

Recommended product model:

LZB-()DK/RE is equipped with glass tube flowmeter purging device

LZZ-()/RE is equipped with metal tube flowmeter purging device



图 4



图 5

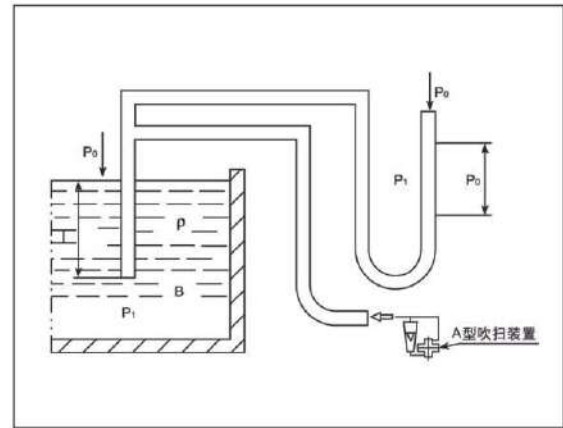

图 6

外形尺寸 Overall dimensions

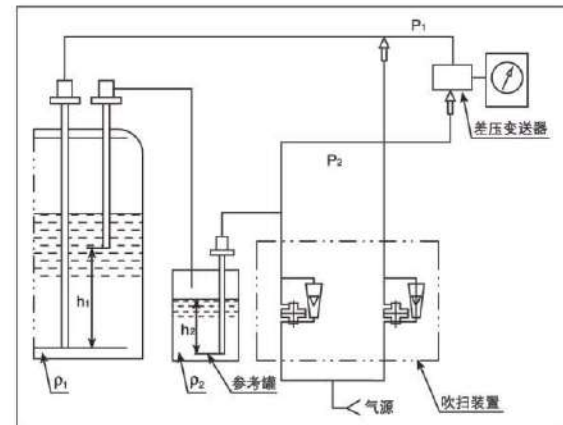

安装注意事项

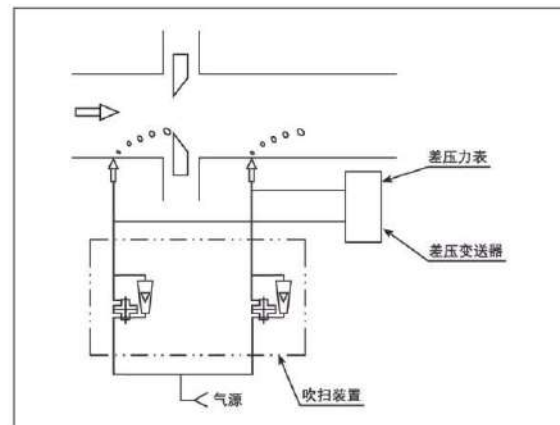
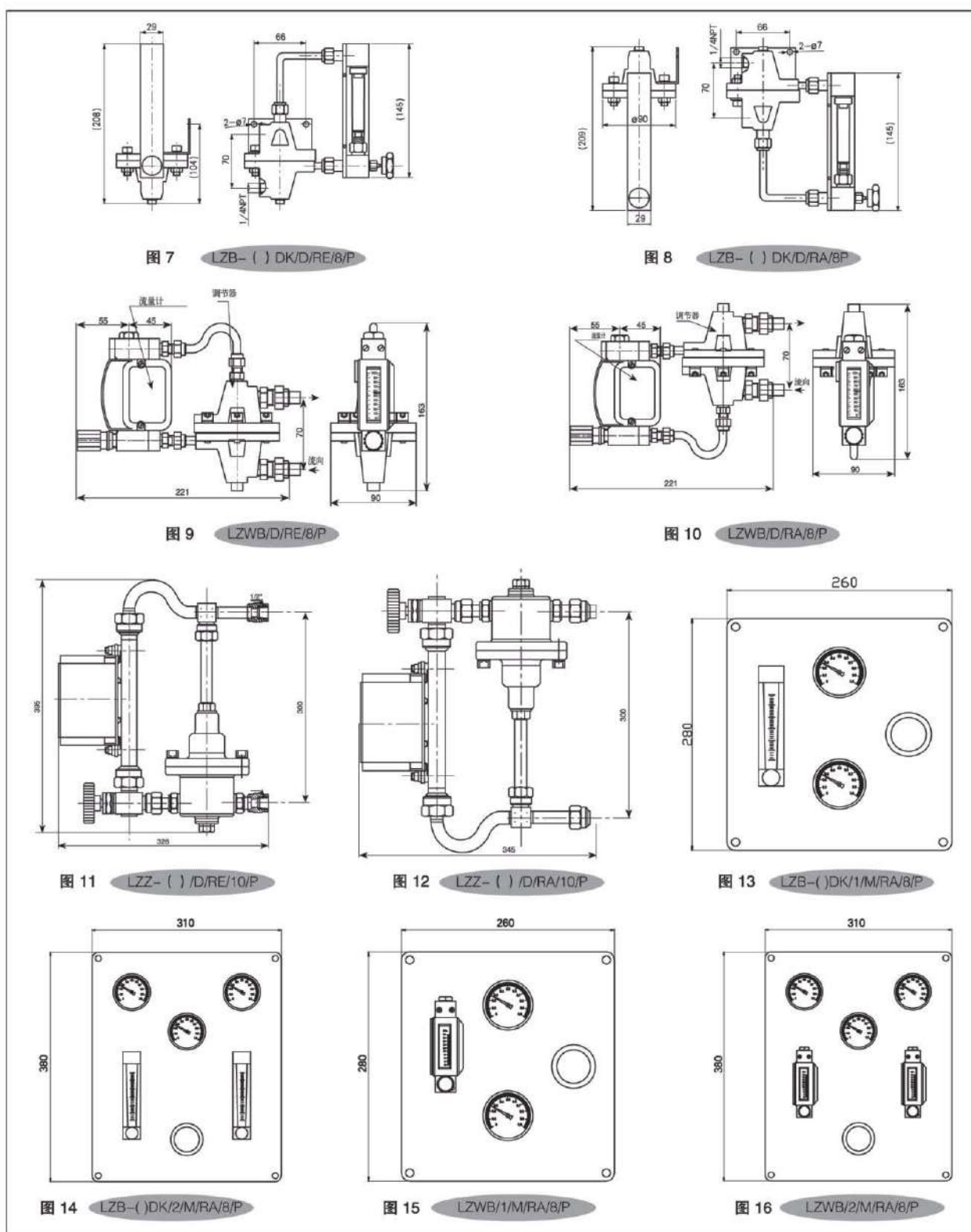
请选择适合的位置安装流量吹扫装置，以确保流量计吹扫装置调试，清洗，拆卸方便。

由于吹扫装置浮子流量计上安装磁耦合传递系统，因此要确保其它工作设备产生的干扰磁场不影响流量计的测量结果。

安装时，要确保流量吹扫装置稳定，应在适当的位置加固固定支架。

安装尺寸，不能超过给定尺寸太多或太少，以避免拉伸和压缩力作用在吹扫装置上。

当液体介质内含有铁磁微粒时，一定要在仪表前将磁性颗粒过滤掉。

一定要确保介质的流向与流量吹扫装置要求的方向相同，在安装仪表时，要把微调针阀全部关闭。

投运前请将管道排空，吹扫干净，以免产生冲击作用，应缓慢打开阀门调整到工作压力，应

通过调整阀门的开度改变流量，防止浮子被冲击，从而损坏测量部件。

Installation precautions

Please choose a suitable location to install the flow purging device to ensure easy debugging, cleaning and disassembly of the flowmeter purging device.

Due to the magnetic coupling transfer system installed on the float flowmeter of the purge device, the measurement results of the flowmeter should be ensured that the interfering magnetic field generated by other working equipment does not affect the flowmeter.

Installation, to ensure that the flow purge device is stable, should be installed in the appropriate location of the fixed bracket.

The mounting size shall not be too much or too little beyond the given size to avoid tension and compression forces acting on the purging device.

When there are ferromagnetic particles in the liquid medium, the magnetic particles must be filtered out before the meter.

Make sure that the flow direction of the medium is the same as that required by the flow rate purging device.

Before putting into operation, please empty the pipe and blow it clean to avoid impact effect. Open the valve slowly and adjust to working pressure. Change the flow rate by adjusting the opening of the valve to prevent the float from being impacted and damaging the measuring parts.

选型代码 Selection of the code

TKLZ系列吹扫装置 Lz series purging device	
1. 仪表型号: TKLZ Instrument model: TKLZ	
2. 分类型号 Classification model Z	
B	选用玻璃管流量计(玻璃转子流量一般选用DK系列) Choose glass tube flowmeter (generally choose DK series for flow of glass rotor)
Z	选用金属管流量计 Choose metal tube flowmeter
WB	选用微小流量金属管流量计 Select micro flow metal tube flowmeter
3. 吹扫形式(若是单表式, 此码可不选) Purge form (if it is a single form, this code is optional)	
1	单路吹扫 Single way purging
2	双路吹扫 Dual purging
3	多路吹扫(特殊可按用户要求) Multiple purge (special to customer's request)
4. 安装形式 Type of installation	
D	单表式 Single table type
M	面板式 panel
5. 压力调节 Pressure regulation	
RE	入口压力调节 Inlet pressure regulation
RA	出口压力调节 Outlet pressure regulation
6. 过程连接 Process connection	
F	法兰连接 Flange connection
S	螺纹连接 Threaded connections
K	卡套连接 Card sleeve connection
0	按用户要求 According to user requirements
7. 材质 The material	
P	304
R	316
N	316L
8. 其它 other	
L	带压力显示 Pressure display
G	带磁过滤器 Magnetic filter

安装附件 *Installing Accessory*

螺纹堵头

螺纹堵头适用于电气设备中有备用的引入装置中起密封作用，可防止水或灰尘进入备用通头内，堵头采用优质碳钢制成。

Thread plug

Thread plug is suitable for spare inlet device of electrical apparatus it has the function of sealing, which can prevent water or dust from entering into spare device and aging, the plug is made of high quality carbon-steel.



护罩

护罩是由PVC制成的，适用于多种规格的电缆接头。

Shroud

The shroud is made of PVC, it is applied to all type cable glands.



接地片

接地片是用于电缆密封接头进线和设备之间提供接地连接。

Earth tag

Earth tag is installed between the cable gland and equipment for earth connection.

接地片规格尺寸Earth tags size	20	25	32	40	50	63	75
额定每秒短路电流 (KA)Short gircuit rating symmetrical fault - current for 1 second	3.06	4.00	5.40	7.20	10.40	10.40	10.40

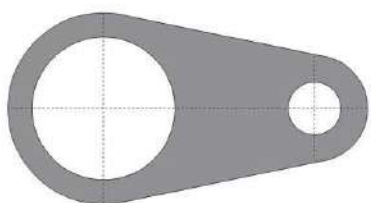

安装管夹

安装管夹是由优质碳钢成形而成，也可根据要求采用不锈钢制成，适用于灯具在现场的安装。

Installing pipe clamp

Installing pipe clamp is made of high-quality carbon-steel, it can also be made of stainless steel, suitable for installing the lamp on the spot.



标准孔板 *Standard Orifice Plate*

特点

具有测量精度高，安装方便，使用范围广，造价低等特点。
广泛应用于各种介质的流量测量。

Characteristics

The standard orifice plate shall be used to measure the medium flowing, which has good features of high accuracy, easy to installed, widely usage and cheap.

规格

DN20~3000mm

Speaification

DN20~3000mm

型号 *Model*

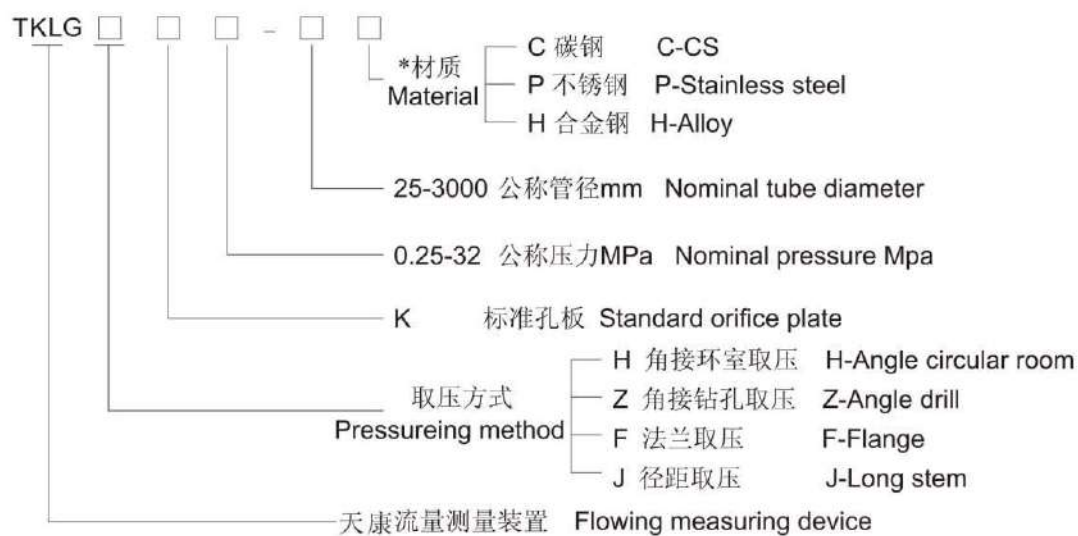

大型孔板
Large Orifice Plate



标准孔板
Standard plate

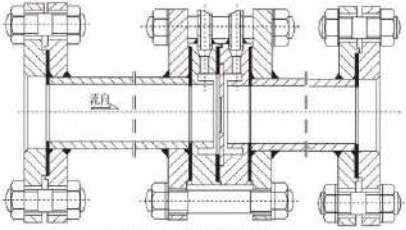
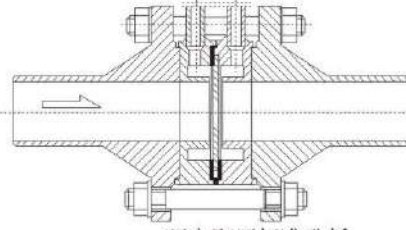
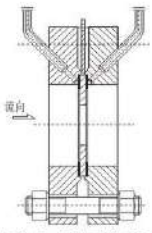
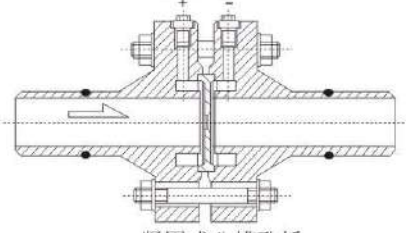
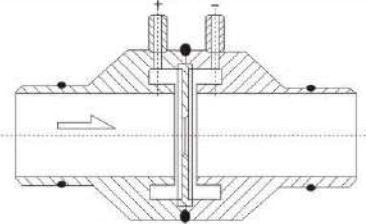
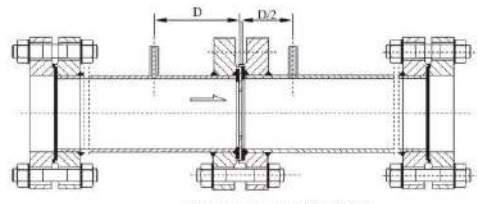
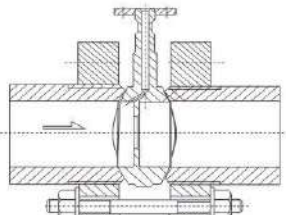
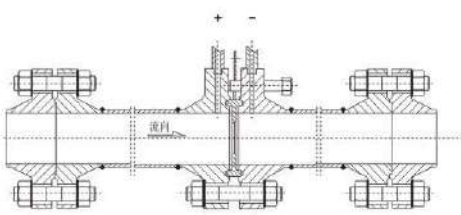
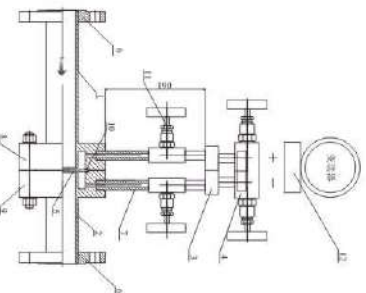
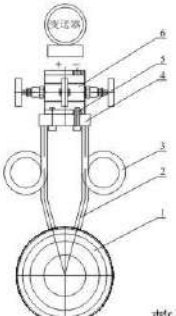

高压透镜垫孔板
High-pressure lens orifice plate

 <p>环室取压标准孔板 PN≤2.5 Circular room standard orifice plate PN≤2.5</p>	 <p>环室取压标准孔板 4.0≤PN≤6.4 Circular room standard orifice plate 4.0≤PN≤6.4</p>
 <p>钻孔取压标准孔板 PN≤2.5 Drill pressing standard orifice plate PN≤2.5</p>	 <p>紧固式八槽孔板 PN≤10 Fastening 8-trough orifice plate PN≤10</p>
 <p>焊接式八槽孔板 PN≥10 Welding 8-trough orifice plate PN≥10</p>	 <p>径距取压标准孔板 PN≤2.5 Long stem standard orifice plate PN≥2.5</p>
 <p>高压透镜垫孔板 PN22,32 High-press lens orifice plate PN22,32</p>	 <p>法兰取压标准孔板 4.0≤PN≤6.4 Flange standard orifice plate 4.0≤PN≤6.4</p>
 <p>内藏孔板安装示意图</p>	 <p>整体孔板示意图</p>

标准喷嘴 *Standard Nozzle*

特点

具有耐高温高压，耐冲击，使用寿命长，测量范围大，测量精度高的特点。适用于电厂高温高压蒸汽流量，热网管路，流速大的流体流量测量。

具有两种形式：A: ISA1932 喷嘴（标准喷嘴）

B: 长径喷嘴

Characteristics

The standard nozzle may be used to measure flowing of high temperature and high pressure steam, heat net tube system and fast flowing in power plant. The standard nozzle shall be resistance to high temperature and high pressure, resistance to vibration, long operation life, widely working range and high accuracy.

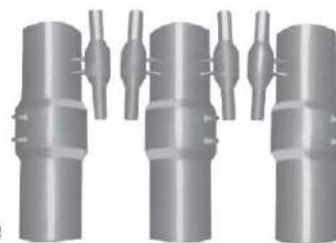

A ISA1932 喷嘴
A ISA1932 nozzle

规格 Specification

$D_N \leq 1000\text{mm}$

型号 Model

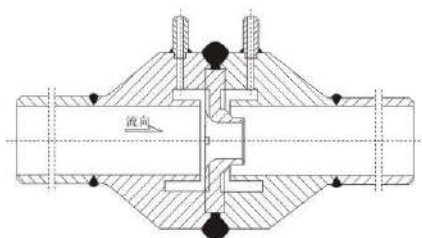
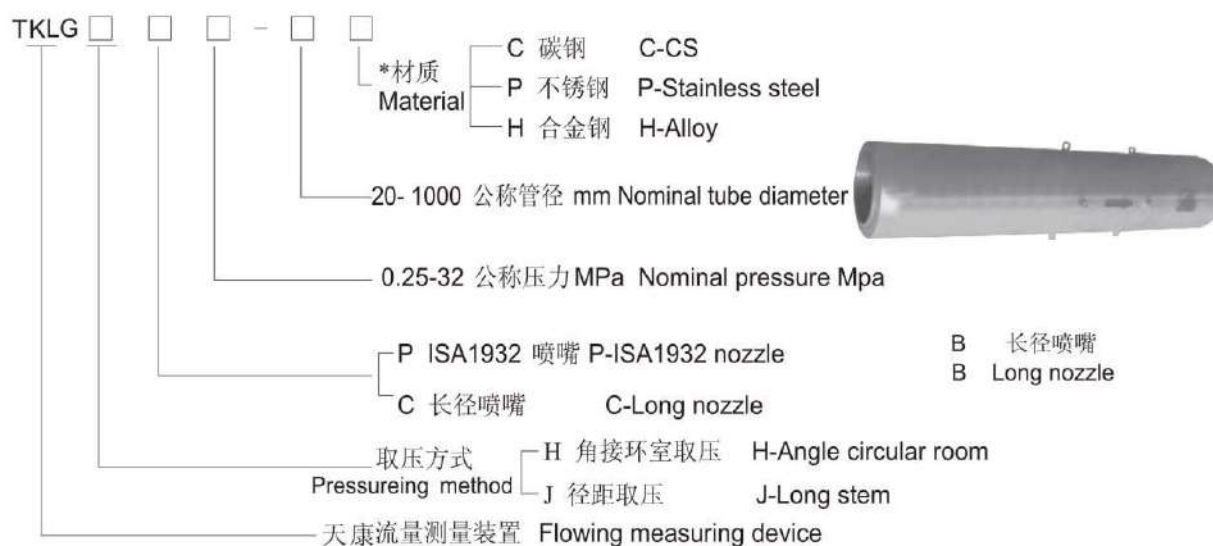

A ISA1932 喷嘴
A ISA1932 nozzle

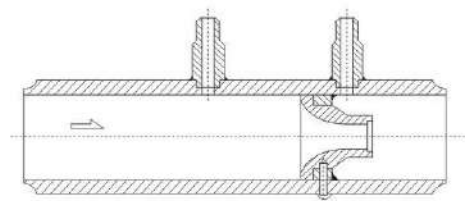

B 长径喷嘴
B Long nozzle

经典文丘里管 文丘里喷嘴

Traditional Wenqiuli Tube, Wenqiuli Nozzle

特点

具有压力损失小，测量精度高，前后直管长度短，使用寿命长的特点。适用于水、气体的流量测量。

Characteristics

The traditional wenqiuli tube and wenqiuli nozzle may be used to measure flowing of water and gas. The traditional wenqiuli tube and wenqiuli nozzle shall be little pressure error, high accuracy, short stright tube, and long operation life.

规格 Specification

50 < DN < 3500mm



文丘里喷嘴
Wenqiuli Nozzle

型号 Model

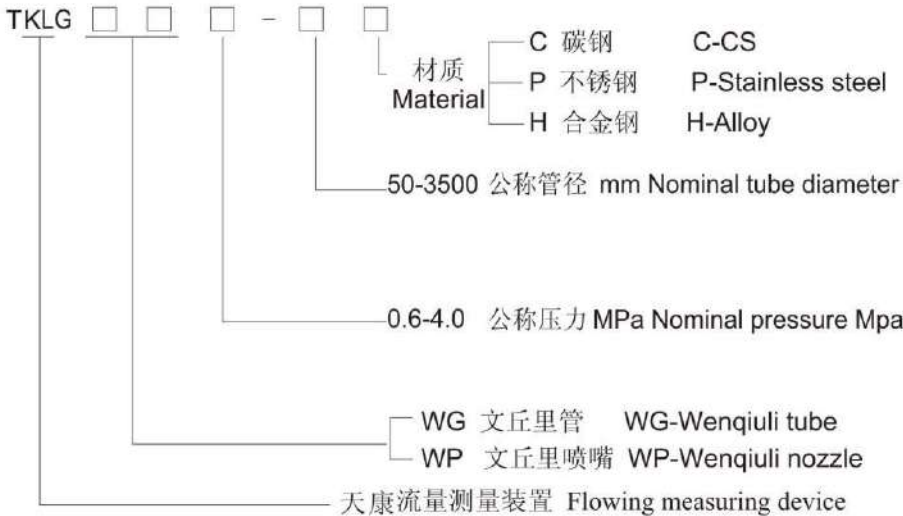

经典文丘里管
Traditional Wenqiuli Nozzle

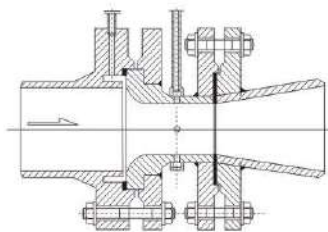

文丘里喷嘴
Wenqiuli nozzle

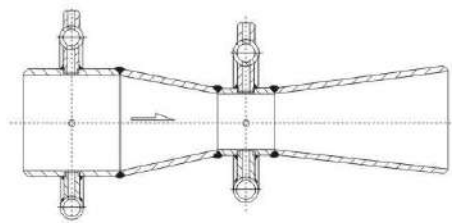

经典文丘里管
Traditional Wenqiuli Nozzle

机翼测风装置 *Measuring Wind Device in Airfoil*

特点

具有压力损失小，前后直管较短，测量稳定的特点。适用于圆形或矩形管道的风量测量。

Characteristics

The measuring wind device in airfoil has little pressure error, stable performance and short stright tube, which may be used to measure wind speed in round and rectangle tubes.

规格 *Specification.*

DN80 - 4000 mm (或长×宽)

DN80 - 4000 mm(or length×width)

型号 *Model*

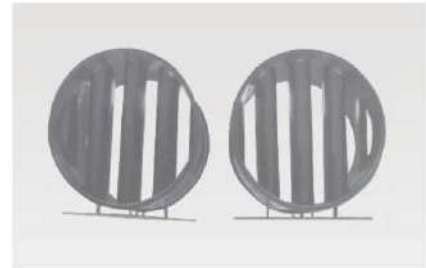
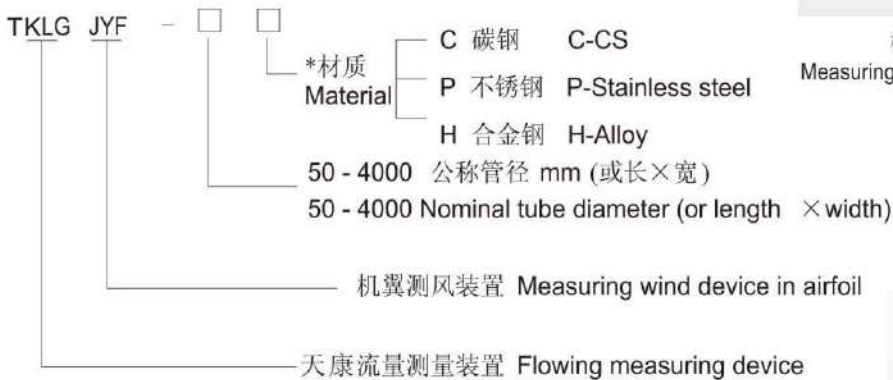

机翼式测风装置 (圆形管道)
Measuring wind device in airfoil (in round tube)



机翼式测风装置 (矩形管道)
Measuring wind device in airfoil (in rectangle tube)

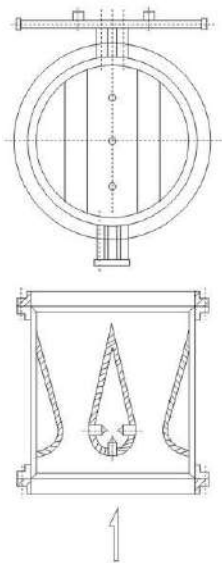

机翼式测风装置 (圆形管道)
Measuring wind device in airfoil (in round tube)

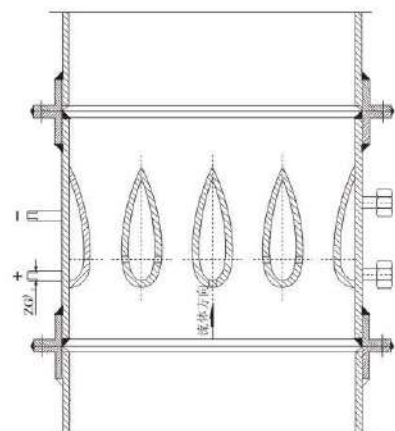

机翼式测风装置 (矩形管道)
Measuring wind device in airfoil (in rectangle tube)

双文丘里管 *Double Wenqiuli Tube*

特点

具有压力损失小，测量稳定的特点，适用于圆形或矩形管道的风量测量。

Characteristics

The double wenqiuli tube has the features of little pressure error, stable performance, which may be used to measure wind speed in round and rectangle tubes.

规格 Specification

DN200-4000mm (或长×宽)

DN200-4000mm (or length×width)

型号 Model

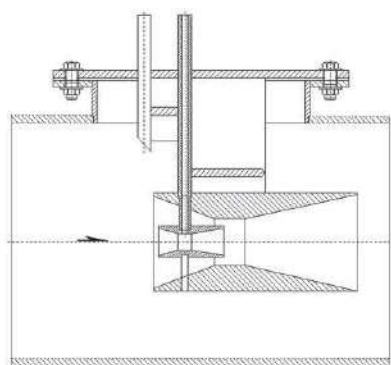
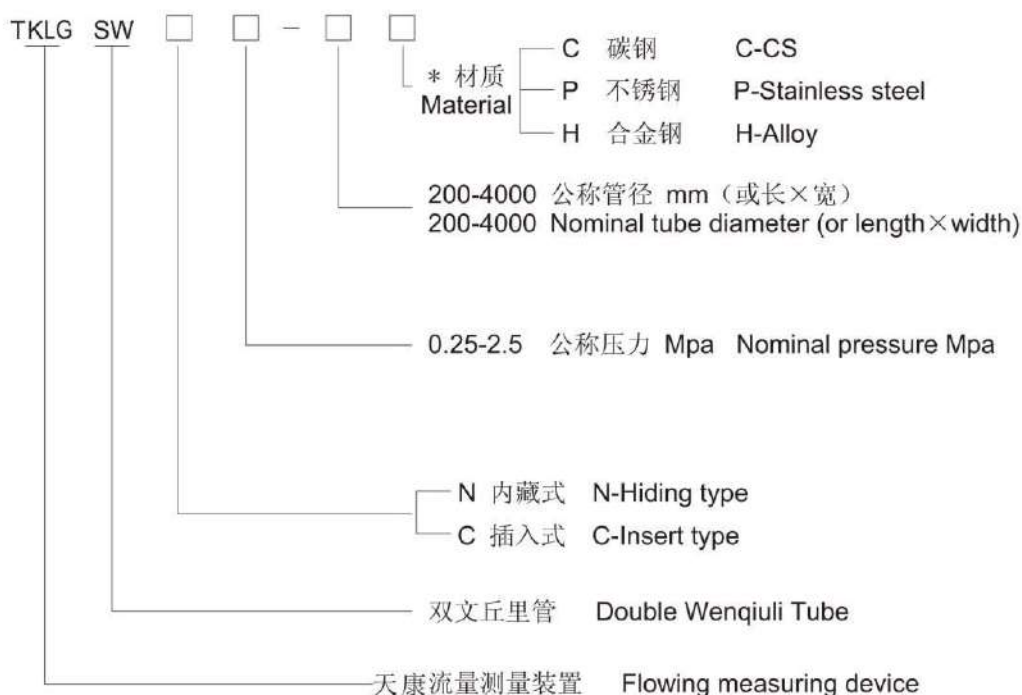

插入式双文丘里管
Insert type Double Wenqiuli Tube

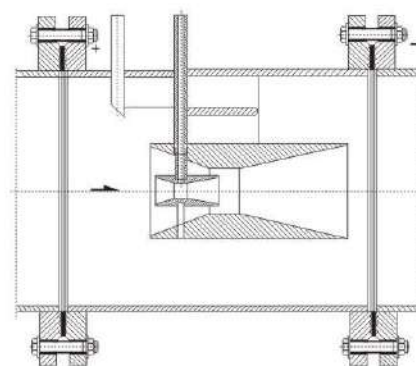

内藏式双文丘里管
Hiding type Insert type Double Wenqiuli Tube

环形孔板、圆缺孔板、偏心孔板 Circular Orifice Plate, Gap-round Orifice Plate, Eccentric Orifice Plate

特点

具有不易堵塞，前后直管较短的特点。适用于高炉煤气、焦炉煤气等含粉尘、杂质较多的气体及液体的测量。

Characteristics

The circular orifice plate, gap-round orifice plate and eccentric orifice plate have short straight tubes and are not easy to be stopped up, which shall be used to measure gas including dirt in high stove and coke oven gas or other gas and liquid containing dust.

规格 Specification

DN50-3500 mm

型号 Model

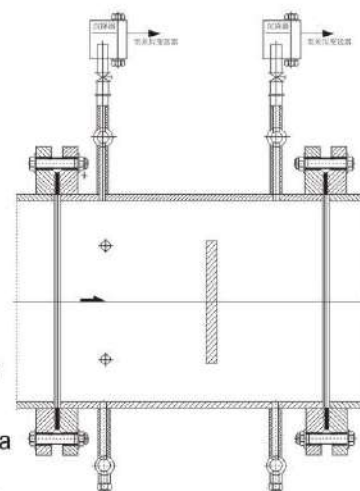
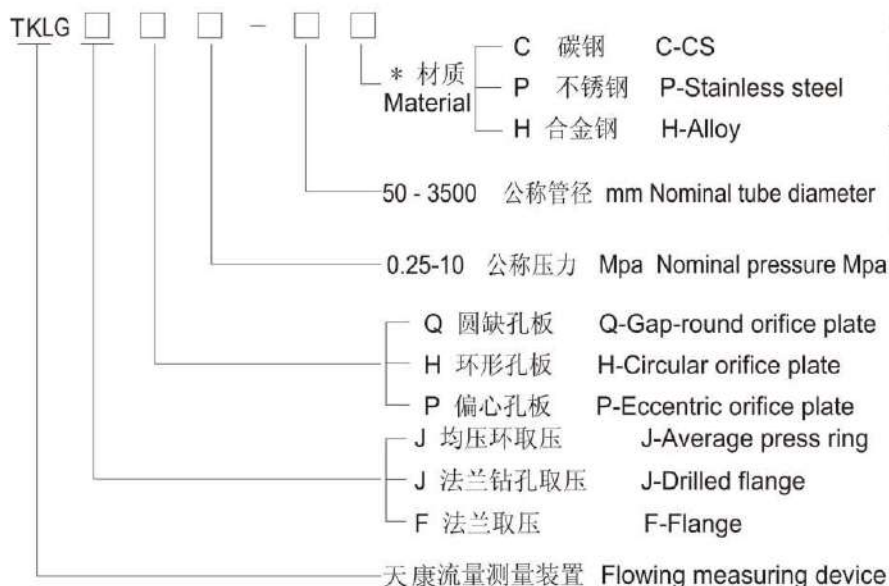

环形孔板
Circular orifice plate

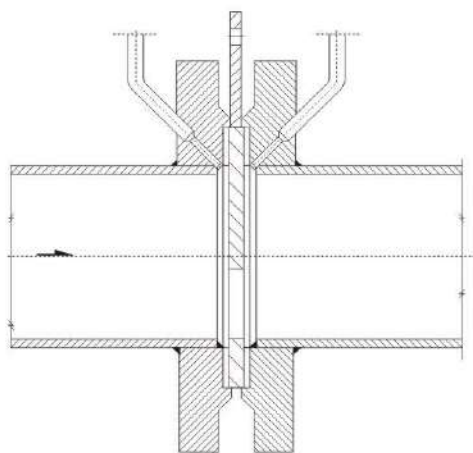

圆缺孔板
Gap-round orifice plate

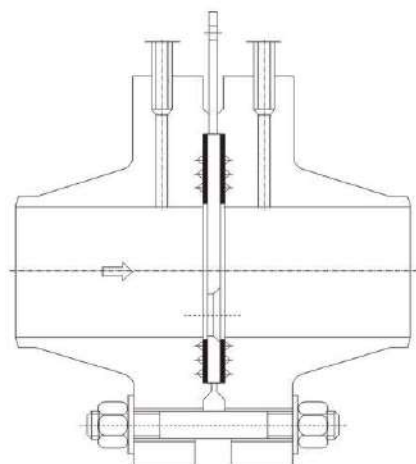

偏心孔板
Eccentric orifice plate

双重孔板 1/4 圆喷嘴

Double Orifice Plate, 1/4 round Nozzle

特点

适用低雷诺数状态下各种流量，广泛应用于各种流速较低的液体、气体的流量测量。

Characteristics

The double orifice plate, 1/4 rond orifice plate shall be used to measure flowing of liquid and gas in slow speed under low Reynold's number.

规格 Specification

DN 25 - 600mm

型号 Model

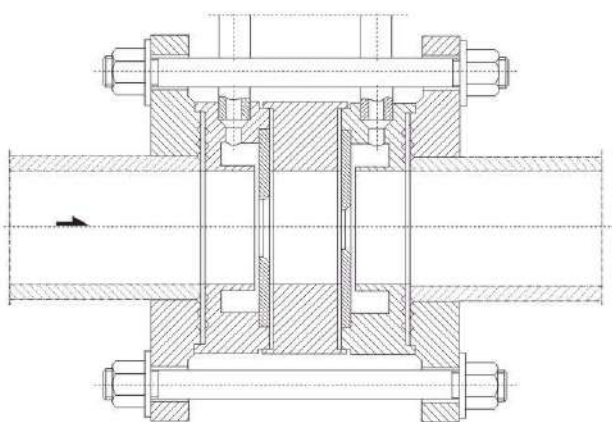
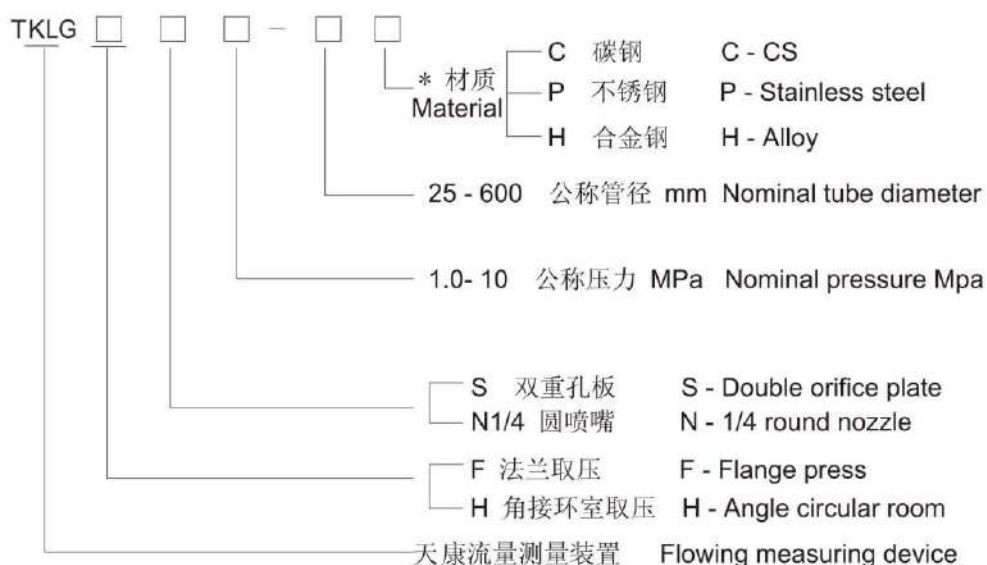

双重孔板
Double Orifice plate

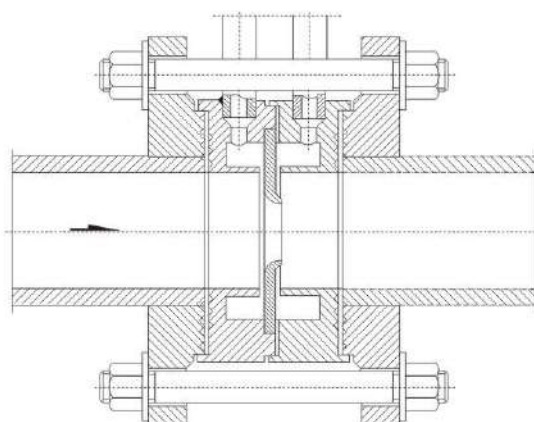

1/4 圆喷嘴
1/4 rond Nozzle

阿牛巴流量计 *Anuba Effusion Meter*

特点

具有压力损失小，安装方便的特点。适用圆形、矩形管道的流量测量。

Characteristics

The anuba effusion meter has the features of little pressure error, easy to be installed, which may be used to measure wind speed in round and rectangle tubes.

规格 Specification

PN<10 DN50~4000

型号 Model

TKANB □ - □ □

* 材质
Material

C	碳钢	C-CS
P	不锈钢	P-Stainless steel
H	合金钢	H-Alloy

50 - 4000 公称管径 mm (或长×宽)
50 - 4000 Nominal tube diameter (or length × width)

0.6-10 公称压力 MPa Nominal pressure MPa

天康阿牛巴流量计 Anuba effusion meter

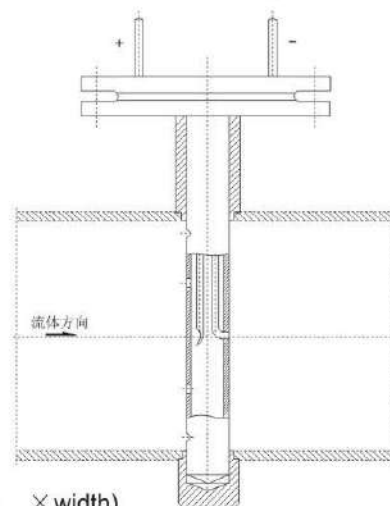

阿牛巴流量计
Anuba effusion meter

限流孔板 *Limite Effusion Meter*

特点

具有限流、降压的特点。适用于限制流量或降低压力。

Characteristics

The limited effusion meter can limite flowing and reduce pressure , which may be used to measure flowing in round or rectangle tube.

规格 Specification

DN10~1000

型号

TKXLKB □ - □ □

* 材质
Material

C	碳钢	C-CS
P	不锈钢	P-Stainless steel
H	合金钢	H-Alloy

10 - 1000 公称管径 mm Nominal tube diameter

0.6-32 公称压力 MPa Nominal pressure MPa

天康限流孔板 Anuba effusion meter

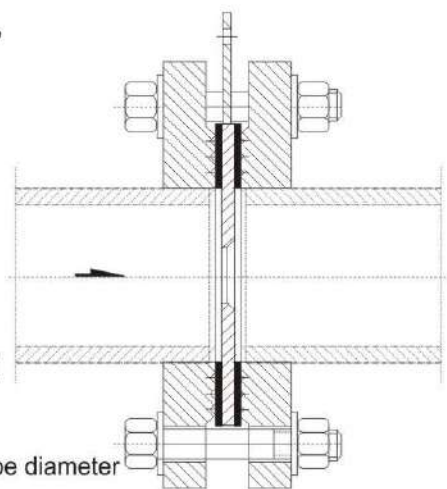

限流孔板
Anuba effusion meter



安徽天康(集团)股份有限公司

ANHUI TIANKANG (GROUP) SHARES CO., LTD.

地址：安徽省天长市仁和南路20号

ADD:NO.20 South Renhe Road,tianchang City,anhui Province

邮编 (ZIP) :239300

电话 (TEL) :0550-7038698/7308802

传真 (FAX) :0550-7038699/7028077

网址 (HTTP) ://www.tiankang.com

电子信箱 (E-mail) :xsc@tiankang.com